

OWNER'S STATEMENT

THE UNDERSIGNED HEREBY CERTIFY THAT THEY ARE THE ONLY PERSONS HAVING ANY RECORD TITLE INTEREST IN THE REAL PROPERTY INCLUDED WITHIN THE SUBDIVISION SHOWN UPON THIS FINAL MAP OF "SIERRA VISTA KT 21A-2" AND THEY HEREBY CONSENT TO THE PREPARATION AND RECORDATION OF THIS FINAL MAP AND HEREBY OFFER FOR DEDICATION AND DO HEREBY DEDICATE FOR PARTICULAR PURPOSES THE FOLLOWING:

THE REAL PROPERTY DESCRIBED BELOW IS DEDICATED AS EASEMENT FOR PUBLIC PURPOSES:

- (A) PUBLIC EASEMENTS FOR THE INSTALLATION AND MAINTENANCE OF, BUT NOT LIMITED TO ELECTROLIERS, WATER AND GAS PIPES, SEWER AND DRAINAGE PIPES, AND FOR UNDERGROUND WIRE AND CONDUITS, ABOVE GROUND APPURTENANCES FOR ELECTRIC, TELEPHONE AND TELEVISION SERVICES AND TRAFFIC CONTROL APPURTENANCES TOGETHER WITH ANY AND ALL APPURTENANCES PERTAINING THERETO ON, OVER, UNDER AND ACROSS SLIVER SPRUCE DRIVE, HIMALAYA WAY, LAKE RANGE WAY, TRINITY ALPS WAY, WADDINGTON WAY, LOT A AND THOSE STRIPS OF LAND LYING CONTIGUOUS TO THE RIGHT OF WAY AS SHOWN HEREON AND DESIGNATED "P.U.E." (PUBLIC UTILITY EASEMENT).

THE REAL PROPERTY DESCRIBED BELOW IS DEDICATED IN FEE FOR PUBLIC PURPOSES:

- (A) AS PUBLIC RIGHT OF WAY (INCLUDING IMPROVEMENTS THEREON) THE STREETS SHOWN HEREON AS SLIVER SPRUCE DRIVE, HIMALAYA WAY, LAKE RANGE WAY, TRINITY ALPS WAY, WADDINGTON WAY AND LOT A.

SIERRA VISTA COMMUNITIES, LLC
A CALIFORNIA LIMITED LIABILITY COMPANY

BY: AKT INVESTMENTS, INC., A CALIFORNIA CORPORATION

BY: _____ BY: _____
 NAME: CHRYSANTHY DEMOS NAME:
 TITLE: PRESIDENT & CEO TITLE:

BY: LENNAR HOMES CALIFORNIA INC., A CALIFORNIA CORPORATION

BY: _____ BY: _____
 NAME: LARRY GUALCO NAME:
 TITLE: VICE PRESIDENT TITLE:

NOTARY'S ACKNOWLEDGMENT

A NOTARY PUBLIC OR OTHER OFFICER COMPLETING THIS CERTIFICATE VERIFIES ONLY THE IDENTITY OF THE INDIVIDUAL WHO SIGNED THE DOCUMENT TO WHICH THIS CERTIFICATE IS ATTACHED, AND NOT THE TRUTHFULNESS, ACCURACY OR VALIDITY OF THAT DOCUMENT.

STATE OF _____ }
COUNTY OF _____ } SS

ON THE _____ DAY OF _____, 2021, BEFORE ME, _____ A NOTARY PUBLIC IN AND FOR SAID COUNTY AND STATE, PERSONALLY APPEARED, _____ WHO PROVED TO ME ON THE BASIS OF _____

SATISFACTORY EVIDENCE TO BE THE PERSON(S) WHOSE NAME(S) IS/ARE SUBSCRIBED TO THE WITHIN INSTRUMENT AND ACKNOWLEDGED TO ME THAT HE/SHE/THEY EXECUTED THE SAME IN HIS/HER/THEIR AUTHORIZED CAPACITY(IES), AND THAT BY HIS/HER/THEIR SIGNATURE(S) ON THE INSTRUMENT THE PERSON(S), OR THE ENTITY UPON BEHALF OF WHICH THE PERSON(S) ACTED, EXECUTED THE INSTRUMENT.

I CERTIFY UNDER PENALTY OF PERJURY UNDER THE LAWS OF THE STATE OF CALIFORNIA THAT THE FOREGOING PARAGRAPH IS TRUE AND CORRECT.

WITNESS MY HAND AND OFFICIAL SEAL: _____

PRINTED NAME: _____

MY PRINCIPAL PLACE OF BUSINESS IS THE COUNTY OF: _____

MY COMMISSION EXPIRES: _____

MY COMMISSION NO.: _____

NOTARY'S ACKNOWLEDGMENT

A NOTARY PUBLIC OR OTHER OFFICER COMPLETING THIS CERTIFICATE VERIFIES ONLY THE IDENTITY OF THE INDIVIDUAL WHO SIGNED THE DOCUMENT TO WHICH THIS CERTIFICATE IS ATTACHED, AND NOT THE TRUTHFULNESS, ACCURACY OR VALIDITY OF THAT DOCUMENT.

STATE OF _____ }
COUNTY OF _____ } SS

ON THE _____ DAY OF _____, 2021, BEFORE ME, _____ A NOTARY PUBLIC IN AND FOR SAID COUNTY AND STATE, PERSONALLY APPEARED, _____ WHO PROVED TO ME ON THE BASIS OF _____

SATISFACTORY EVIDENCE TO BE THE PERSON(S) WHOSE NAME(S) IS/ARE SUBSCRIBED TO THE WITHIN INSTRUMENT AND ACKNOWLEDGED TO ME THAT HE/SHE/THEY EXECUTED THE SAME IN HIS/HER/THEIR AUTHORIZED CAPACITY(IES), AND THAT BY HIS/HER/THEIR SIGNATURE(S) ON THE INSTRUMENT THE PERSON(S), OR THE ENTITY UPON BEHALF OF WHICH THE PERSON(S) ACTED, EXECUTED THE INSTRUMENT.

I CERTIFY UNDER PENALTY OF PERJURY UNDER THE LAWS OF THE STATE OF CALIFORNIA THAT THE FOREGOING PARAGRAPH IS TRUE AND CORRECT.

WITNESS MY HAND AND OFFICIAL SEAL: _____

PRINTED NAME: _____

MY PRINCIPAL PLACE OF BUSINESS IS THE COUNTY OF: _____

MY COMMISSION EXPIRES: _____

MY COMMISSION NO.: _____

SURVEYOR'S STATEMENT

THIS FINAL MAP OF "SIERRA VISTA KT 21A-2" WAS PREPARED BY ME OR UNDER MY DIRECTION AND IS BASED UPON A FIELD SURVEY IN CONFORMANCE WITH THE REQUIREMENTS OF THE SUBDIVISION MAP ACT AND LOCAL ORDINANCES AT THE REQUEST OF SIERRA VISTA COMMUNITIES, LLC, A CALIFORNIA LIMITED LIABILITY COMPANY, IN DECEMBER 2019. I HEREBY STATE THAT THIS FINAL MAP SUBSTANTIALLY CONFORMS TO THE APPROVED OR CONDITIONALLY APPROVED TENTATIVE MAP. ALL MONUMENTS SHOWN HEREON ARE OF THE CHARACTER AND WILL OCCUPY THE POSITIONS INDICATED, AND WILL BE SET BY DECEMBER 31, 2022 AND THAT THE MONUMENTS ARE SUFFICIENT TO ENABLE THE SURVEY TO BE RETRACED.

R.E.Y. ENGINEERS, INC.

CRAIG E. SPIESS, PLS 7944
EXPIRATION DATE: DECEMBER 31, 2021

DATE: _____



CITY ENGINEER'S STATEMENT

I HEREBY STATE THAT I HAVE EXAMINED THIS FINAL MAP OF "SIERRA VISTA KT 21A-2" AND FIND IT TO BE SUBSTANTIALLY THE SAME AS THE TENTATIVE MAP ON FILE AND ANY APPROVED ALTERATIONS THEREOF; THAT ALL PROVISIONS OF THE SUBDIVISION MAP ACT AND ALL APPLICABLE CITY ORDINANCES HAVE BEEN COMPLIED WITH.

DATE: _____

MARC STOUT, R.C.E. 69879
CITY ENGINEER, CITY OF ROSEVILLE
LICENSE EXPIRES: SEPTEMBER 30, 2022

I HEREBY STATE THAT I AM SATISFIED WITH THIS FINAL MAP OF "SIERRA VISTA KT-21A-2" IS TECHNICALLY CORRECT.

FOR MARC STOUT, CITY ENGINEER, CITY OF ROSEVILLE

DATE: _____

TIMOTHY G. BLAIR, PLS 8278
EXPIRES DECEMBER 31, 2021

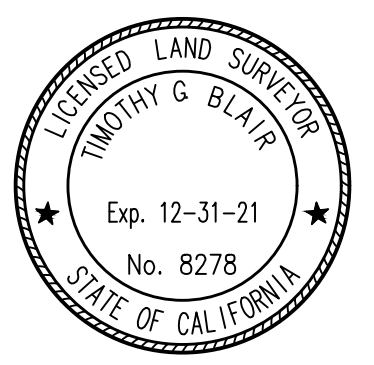

CITY CLERK'S STATEMENT

I HEREBY CERTIFY THAT THE CITY COUNCIL OF THE CITY OF ROSEVILLE, HAS APPROVED THIS FINAL MAP OF "SIERRA VISTA KT 21A-2", AND HAS ACCEPTED ON BEHALF OF THE PUBLIC THE PUBLIC UTILITY EASEMENTS OFFERED HEREON OF DEDICATIONS AND HAS ACCEPTED, SUBJECT TO IMPROVEMENT, LOT A AND ALL RIGHTS-OF-WAY OFFERED HEREON FOR DEDICATION IN ACCORDANCE WITH THE TERMS OF THAT OFFER.

CITY CLERK, CITY OF ROSEVILLE

DATE: _____ BY: _____
ASSISTANT CITY CLERK

RECORDER'S STATEMENT

FILED THIS _____ DAY OF _____, 2021, AT _____ M. IN BOOK _____ OF MAPS, AT PAGE _____, IN THE OFFICE OF THE PLACER COUNTY RECORDER, STATE OF CALIFORNIA, AT THE REQUEST OF R.E.Y. ENGINEERS, INC.

RECORDER OF PLACER COUNTY STATE OF CALIFORNIA DOCUMENT NO.: _____

BY: _____ FEE: \$ _____
DEPUTY

**FINAL MAP OF
SIERRA VISTA
KT 21A-2
SUBDIVISION No. PL17-0305**

BEING A SUBDIVISION OF REMAINDER LOT AS SHOWN AND SO DESIGNATED ON THAT CERTAIN FINAL MAP ENTITLED "SIERRA VISTA KT 21A-1", FILED FOR RECORD ON _____, 2021 IN BOOK _____ OF MAPS, AT PAGE _____, PLACER COUNTY RECORDS, SECTION 35, TOWNSHIP 11 NORTH, RANGE 5 EAST, MOUNT DIABLO MERIDIAN.

CITY OF ROSEVILLE • PLACER COUNTY • CALIFORNIA

R. E. Y. ENGINEERS, Inc.
Civil Engineers / Land Surveyors
905 Sutter St. Ste 200 Folsom CA 95630
(916) 366-3040 Fax (916) 366-3303

APRIL 2021

FEDERICO LARGE LOT FINAL MAP EE
MAPS 6

MOURIER INVESTMENTS,
LLC
DN 2007-0076354

Line Table			CURVE TABLE				
#	BEARING	LENGTH	#	RADIUS	DELTA	CHORD BEARING	CHORD LENGTH
L8(3)	N1°04'26"W	21.00'	C3(2)(3)	22'	94°07'46"	36.14'	N44°00'33"W 32.21'
L9(3)	N10°03'55"E	56.08'	C4(3)	229'	07°00'35"	28.02'	N06°33'38"E 28.00'
L10(3)	N88°55'34"E	12.24'	C5(3)	271'	07°05'08"	33.51'	N06°31'21"E 33.49'
L11(3)	N1°04'26"W	42.00'	C6(3)	22'	85°56'46"	33.00'	N45°57'11"E 29.99'
L12(3)	N88°55'34"E	11.00'	C7(3)	22'	90°26'09"	34.72'	N45°51'21"W 31.23'
L13(3)	N0°38'17"W	116.00'	C8(3)	22'	89°33'51"	34.39'	N44°08'39"E 30.99'
L14(3)	N88°55'34"E	11.65'	C9(3)	22'	90°26'09"	34.72'	N45°51'21"W 31.23'
L15(3)	N1°04'26"W	42.00'	C10(3)	22'	89°33'51"	34.39'	N44°08'39"E 30.99'
L16(3)	N88°55'34"E	11.00'	C11(3)	22'	90°26'09"	34.72'	N45°51'21"W 31.23'
L17(3)	N0°38'17"W	116.00'	C12(3)	31'	89°33'51"	48.46'	N44°08'39"E 43.67'
L18(3)	N88°55'34"E	13.65'					
L19(3)	N1°04'26"W	42.00'					
L20(3)	N88°55'34"E	11.00'					
L21(3)	N0°38'17"W	67.04'					
L22(3)	N89°21'43"E	4.00'					

- NOTES:**
- THE TOTAL AREA OF THIS SUBDIVISION IS 9.54 ACRES +/-, GROSS, CONSISTING OF 66 RESIDENTIAL LOTS, 1 LANDSCAPE LOT.
 - ALL CURVES ARE DIMENSIONED WITH RADIUS, DELTA, ARC LENGTH, CHORD BEARING AND CHORD LENGTH. CHORD LENGTHS MAY CONTAIN SOME ROUNDING ERROR. DISTANCES SHOWN HEREON ARE IN FEET AND DECIMALS THEREOF AND ARE "GROUND" DISTANCES.
 - A PRELIMINARY SOILS REPORT WAS PREPARED BY WALLACE KUHLE & ASSOCIATES DATED FEBRUARY 12, 2018; PROJECT NUMBER WKA NO. 11712.02P AND ON FILE WITH THE CITY OF ROSEVILLE DEVELOPMENT - ENGINEERING DEPARTMENT FILE #308-876.
 - ALL FRONT CORNERS ARE MARKED BY A 1" BRASS MARKER STAMPED "LS 7944" IN THE SIDEWALK ON THE EXTENSION OF SIDE LOT LINES 1.00' FROM THE PROPERTY LINE UNLESS OTHERWISE NOTED.
 - ALL REAR CORNERS AND ANGLE POINTS WILL BE SET WITH A 5/8" REBAR AND PLASTIC CAP STAMPED "LS 7944". WHERE REAR CORNER FALLS WITHIN A MASONRY RETAINING WALL, MASONRY SOUND WALL OR CONCRETE FOOTING, A 5/8" REBAR WITH PLASTIC CAP STAMPED "LS 7944" WILL BE SET ON THE SIDE LOT LINE 4.00 FOOT OFFSET TO THE REAR CORNER OR A BRASS TAG STAMPED "LS 7944" WILL BE SET WITH EPOXY TO THE FACE WALL 2.00 FOOT ABOVE GROUND OR ON TOP OF WALL WHERE AS OFFSET MONUMENT CANNOT BE SET.
 - A PORTION OF THE I.O.D./R.O.W. ON LOT 10 AS SHOWN AND SO DESIGNATED ON THAT CERTAIN FINAL MAP ENTITLED "SIERRA VISTA - KT PROPERTIES PHASE 2 LARGE LOT SUBDIVISION SUBDIVISION NUMBER PL 15-0192", FILED FOR RECORD ON OCTOBER 1, 2020 IN BOOK FF OF MAPS, AT PAGE 18, PLACER COUNTY RECORDS, IS FULLY CONTAINED IN THE RIGHT OF WAY SHOWN HEREON.
 - COVENANTS, CONDITIONS AND RESTRICTIONS AFFECTING THE LOTS SHOWN HEREON ARE RECORDED AS DOCUMENT NO. 2020-0042952 OFFICIAL RECORDS OF PLACER COUNTY.

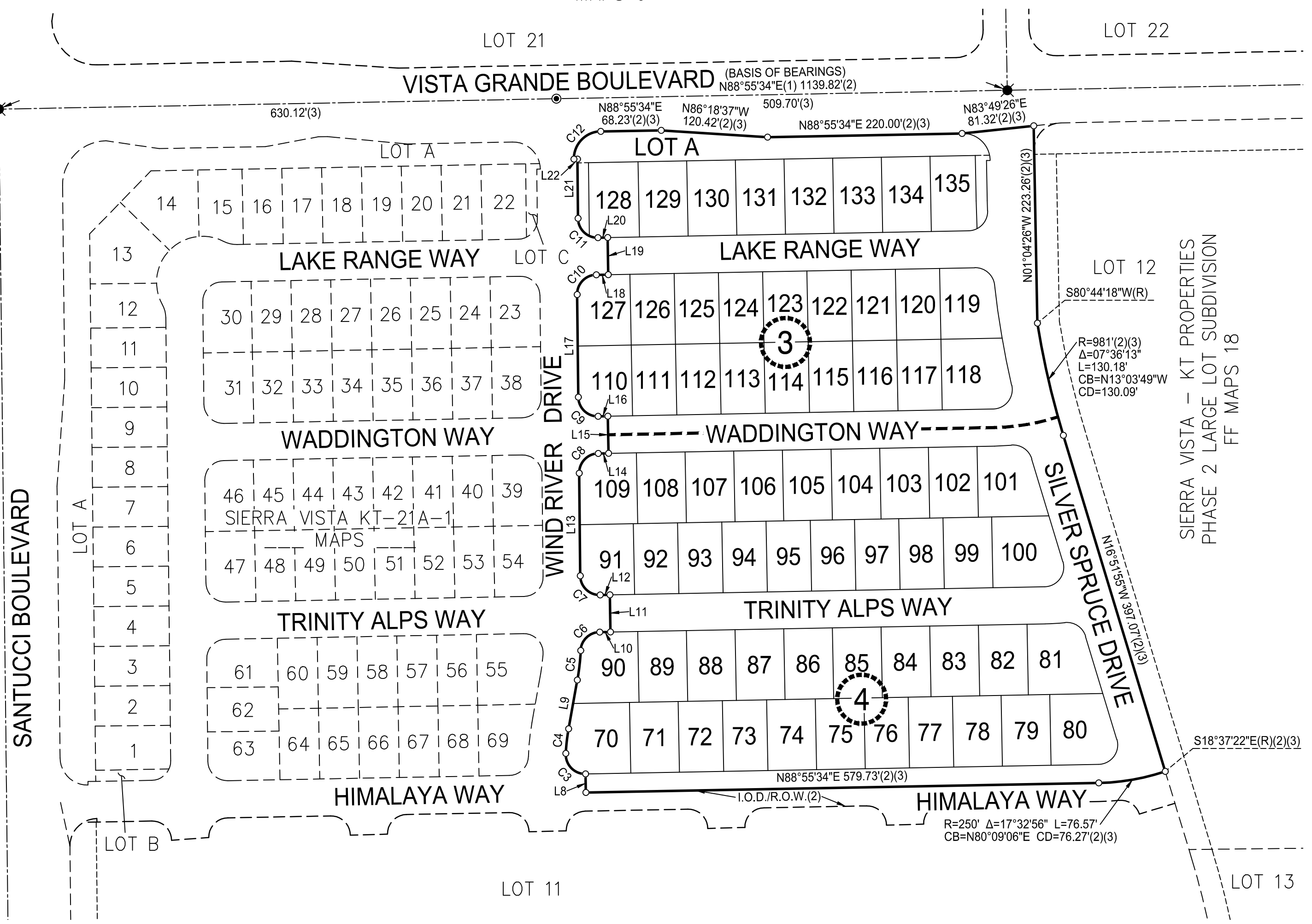

BASIS OF BEARINGS:
THE BEARING N 88°55'34" E, AS SHOWN BETWEEN FOUND MONUMENTS ALONG THE CENTERLINE OF VISTA GRANDE BOULEVARD AS SHOWN ON THAT CERTAIN FINAL MAP ENTITLED "SIERRA VISTA - KT PROPERTIES PHASE 2 LARGE LOT SUBDIVISION SUBDIVISION NUMBER PL 15-0192" FILED FOR RECORD ON OCTOBER 1, 2020 IN BOOK FF OF MAPS, AT PAGE 18, PLACER COUNTY RECORDS. DISTANCES SHOWN HEREON ARE GROUND DISTANCES.

REFERENCES:
(1) EE MAPS 6
(2) FF MAPS 18
(3) ___ MAPS ___(KT-21A-1)

- LEGEND**
- MONUMENT TO BE SET PER (2) COPPERWELD SURVEY MONUMENT WITH CENTER PUNCH IN MONUMENT WELL STAMPED "LS 7944"
 - SET COPPERWELD SURVEY MONUMENT WITH CENTER PUNCH IN MONUMENT WELL STAMPED "LS 7944"
 - DIMENSION POINT NOTHING FOUND OR SET
 - CB CHORD BEARING
 - CD CHORD DISTANCE
 - (OA) OVERALL
 - P.E. PEDESTRIAN EASEMENT
 - P.U.E. PUBLIC UTILITY EASEMENT
 - (R) RADIAL
 - S.F. SQUARE FEET
 - () DENOTES RECORD INFORMATION
 - 1 SHEET NUMBER

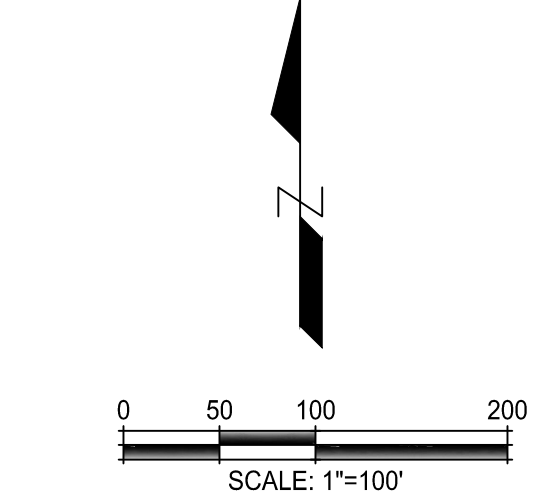

**FINAL MAP OF
SIERRA VISTA
KT 21A-2
SUBDIVISION No. PL17-0305**

BEING A SUBDIVISION OF REMAINDER LOT AS SHOWN AND SO DESIGNATED ON THAT CERTAIN FINAL MAP ENTITLED "SIERRA VISTA KT 21A-1", FILED FOR RECORD ON _____, 2021 IN BOOK ___ OF MAPS, AT PAGE ___, PLACER COUNTY RECORDS, SECTION 35, TOWNSHIP 11 NORTH, RANGE 5 EAST, MOUNT DIABLO MERIDIAN.

CITY OF ROSEVILLE • PLACER COUNTY • CALIFORNIA
R. E. Y. ENGINEERS, Inc.
Civil Engineers / Land Surveyors
905 Sutter St. Ste 200 Folsom CA 95630
(916) 366-3040 Fax (916) 366-3303
APRIL 2021
SHEET 2 OF 5 7310.024

FEDERICO LARGE LOT FINAL MAP EE
 MAPS 6
 LOT 21

VISTA GRANDE BOULEVARD
 (I.O.D./R.O.W.)(1)(2) (BASIS OF BEARINGS)
 N88°55'34"E(1) 1139.82'(2)
 509.70'

CURVE TABLE

#	RADIUS	DELTA	LENGTH	CHORD BEARING	CHORD LENGTH
C1	22'	90°26'09"	34.72'	N45°51'21"W	31.23'
C2	22'	89°33'51"	34.39'	N44°08'39"E	30.99'
C3	22'	90°26'09"	34.72'	N45°51'21"W	31.23'
C4	22'	64°25'01"	24.73'	N32°50'48"W	23.45'
C5	22'	26°01'08"	9.99'	N78°03'52"W	9.90'
C6	31'	90°00'00"	48.69'	N48°04'26"W	43.84'
C7	1000'	03°08'05"	54.71'	N02°38'28"W	54.70'
C8	1025'	00°38'21"	11.44'	N01°23'37"W	11.44'
C9	1037.50'	01°43'49"	31.33'	N01°56'20"W	31.33'
C10	22'	90°38'21"	34.80'	N43°36'23"E	31.29'
C11	22'	63°52'22"	24.53'	N30°13'24"E	23.28'
C12	22'	26°45'59"	10.28'	N75°32'34"E	10.18'
C13	22'	84°38'11"	32.50'	N48°45'20"W	29.62'
C14	22'	101°47'57"	39.09'	N38°01'36"E	34.15'
C15	250'	12°25'51"	54.24'	N82°42'39"E	54.13'
C16	1000'	01°15'55"	22.08'	N16°13'58"W	22.08'

RADIAL TABLE

#	BEARING
R1	S87°11'45"W(R) R=1037.5'
R2	S27°50'25"E(R) R=22'
R3	S13°30'17"E(R) R=250'
R4	S074°24'00"W(R) R=1000'

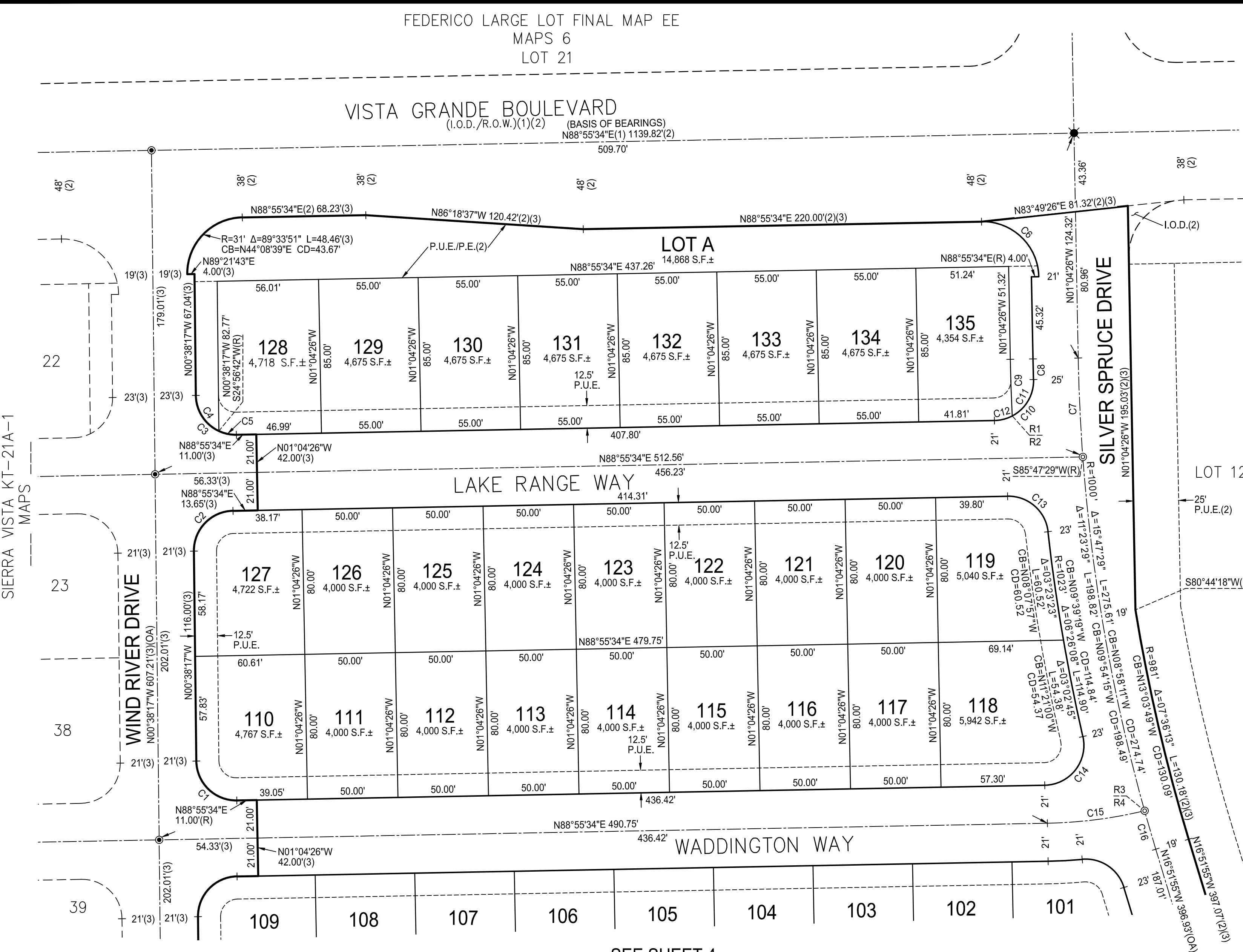

SIERRA VISTA - KT PROPERTIES
 PHASE 2 LARGE LOT SUBDIVISION
 FF MAPS 18

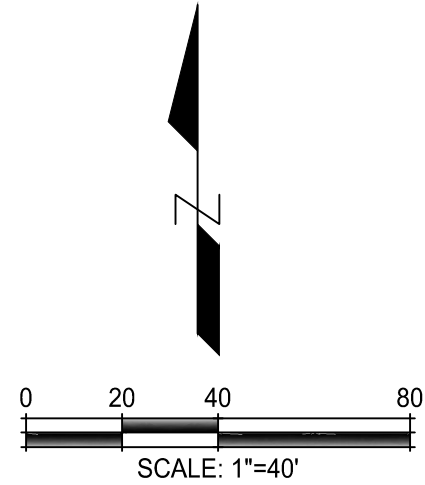

**FINAL MAP OF
 SIERRA VISTA
 KT 21A-2
 SUBDIVISION No. PL17-0305**

BEING A SUBDIVISION OF REMAINDER LOT AS SHOWN AND SO DESIGNATED ON THAT CERTAIN FINAL MAP ENTITLED "SIERRA VISTA KT 21A-1", FILED FOR RECORD ON _____, 2021 IN BOOK _____ OF MAPS, AT PAGE _____, PLACER COUNTY RECORDS, SECTION 35, TOWNSHIP 11 NORTH, RANGE 5 EAST, MOUNT DIABLO MERIDIAN.

CITY OF ROSEVILLE • PLACER COUNTY • CALIFORNIA

R. E. Y. ENGINEERS, Inc.
 Civil Engineers / Land Surveyors
 905 Sutter St. Ste 200 Folsom CA, 95630
 (916) 366-3040 Fax (916) 366-3303

APRIL 2021

SHEET 3 OF 5 7310.024

SEE SHEET 2 FOR BASIS OF BEARINGS, LEGEND, NOTES & REFERENCES

SEE SHEET 4

FINAL MAP OF
SIERRA VISTA
KT 21A-2

SUBDIVISION No. PL17-0305

BEING A SUBDIVISION OF REMAINDER LOT AS SHOWN AND SO DESIGNATED ON THAT CERTAIN FINAL MAP ENTITLED "SIERRA VISTA KT 21A-1", FILED FOR RECORD ON 2021 IN BOOK OF MAPS, AT PAGE PLACER COUNTY RECORDS, SECTION 35, TOWNSHIP 11 NORTH, RANGE 5 EAST, MOUNT DIABLO MERIDIAN.

CITY OF ROSEVILLE • PLACER COUNTY • CALIFORNIA

R. E. Y. ENGINEERS, Inc.
Civil Engineers / Land Surveyors
905 Sutter St, Ste 200 Folsom CA, 95630
(916) 366-3040 Fax (916) 366-3303

APRIL 2021

7310.024

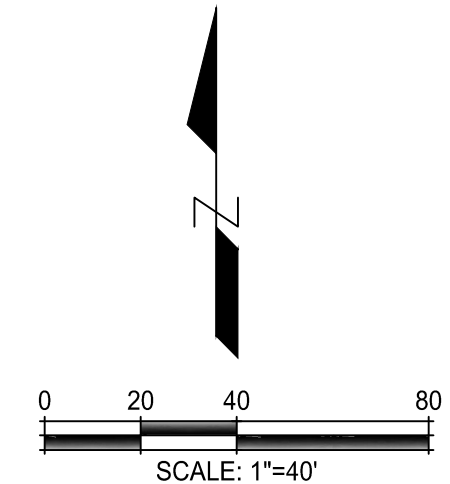
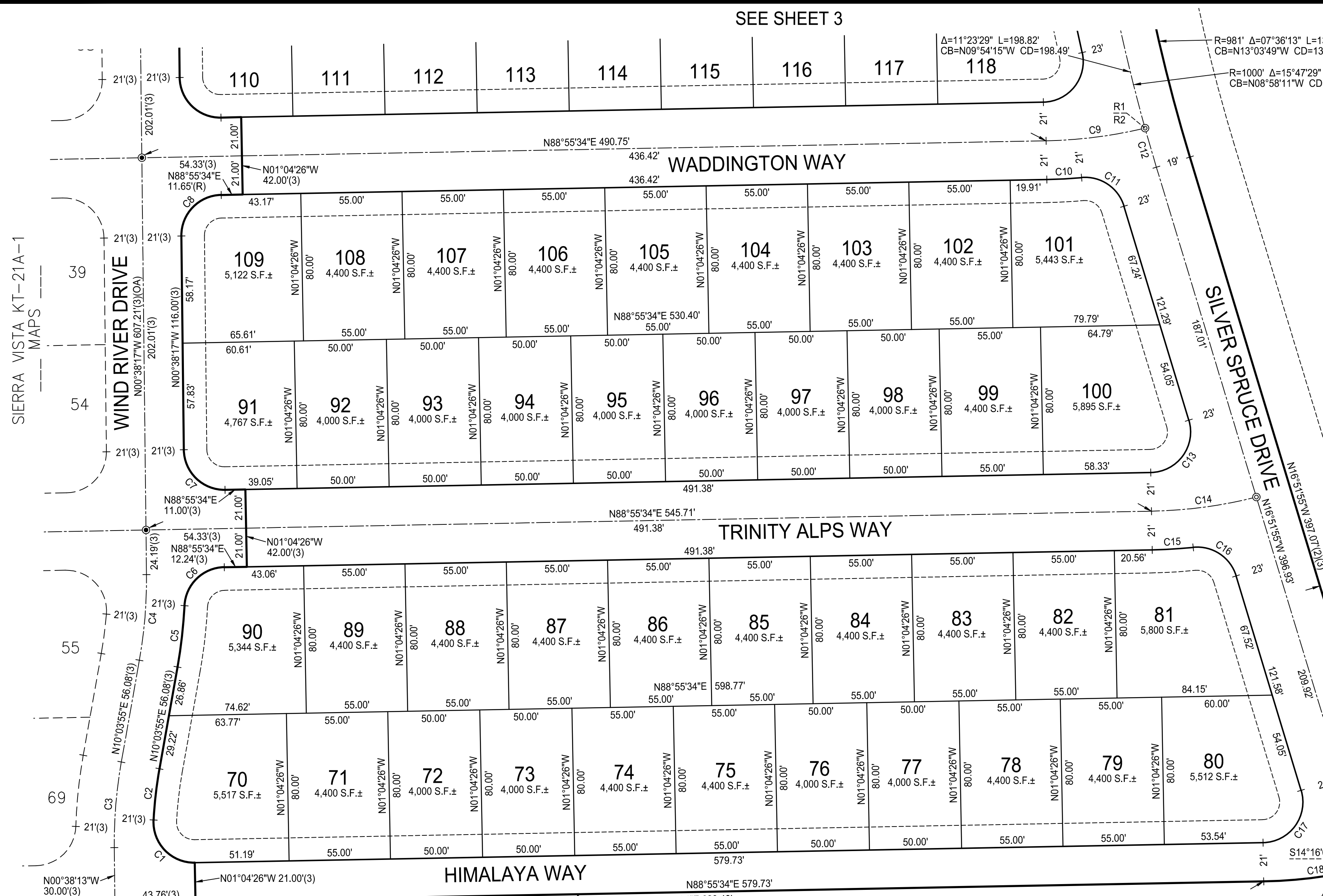

CURVE TABLE

#	RADIUS	DELTA	LENGTH	BEARING	CHORD LENGTH	CHORD BEARING
C1(3)	22'	94°07'46"	36.14'	N44°00'33"W	32.21'	
C2(3)	229'	07°00'35"	28.02'	N06°33'38"E	28.00'	
C3(3)	250'	10°42'08"	46.70'	N04°42'51"E	46.63'	
C4(3)	250'	10°42'12"	46.70'	N04°42'49"E	46.63'	
C5(3)	271'	07°05'08"	33.51'	N06°31'21"E	33.49'	
C6(3)	22'	85°56'46"	33.00'	N45°57'11"E	29.99'	
C7(3)	22'	90°26'09"	34.72'	N45°51'21"W	31.23'	
C8(3)	22'	89°33'51"	34.39'	N44°08'39"E	30.99'	
C9	250'	12°25'51"	54.24'	N82°42'39"E	54.13'	
C10	271'	03°59'42"	18.90'	N86°55'43"E	18.89'	
C11	22'	78°12'13"	30.03'	N55°58'02"W	27.75'	
C12	1000'	01°15'55"	22.08'	N16°13'58"W	22.08'	
C13	22'	105°47'29"	40.62'	N36°01'49"E	35.09'	
C14	250'	13°11'36"	57.57'	N82°19'46"E	57.44'	
C15	271'	04°42'24"	22.26'	N86°34'22"E	22.26'	
C16	22'	78°54'55"	30.30'	N56°19'23"W	27.96'	
C17	22'	105°47'29"	40.62'	N36°01'49"E	35.09'	
C18	250'	13°11'36"	57.57'	N82°19'46"E	57.44'	
C19	250'	04°21'20"	19.01'	N73°33'18"E	19.00'	

RADIAL TABLE

#	BEARING
R1	S13°30'17"E(R) R=250'
R2	S074°24'00"W(R) R=1000'

SIERRA VISTA KT-21A-1
MAPS

SIERRA VISTA - KT PROPERTIES
PHASE 2 LARGE LOT SUBDIVISION
FF MAPS 18

SIERRA VISTA - KT PROPERTIES
PHASE 2 LARGE LOT SUBDIVISION
FF MAPS 18

MOURIER INVESTMENTS, LLC
DN 2007-0076354

FEDERICO LARGE LOT FINAL MAP EE
MAPS 6

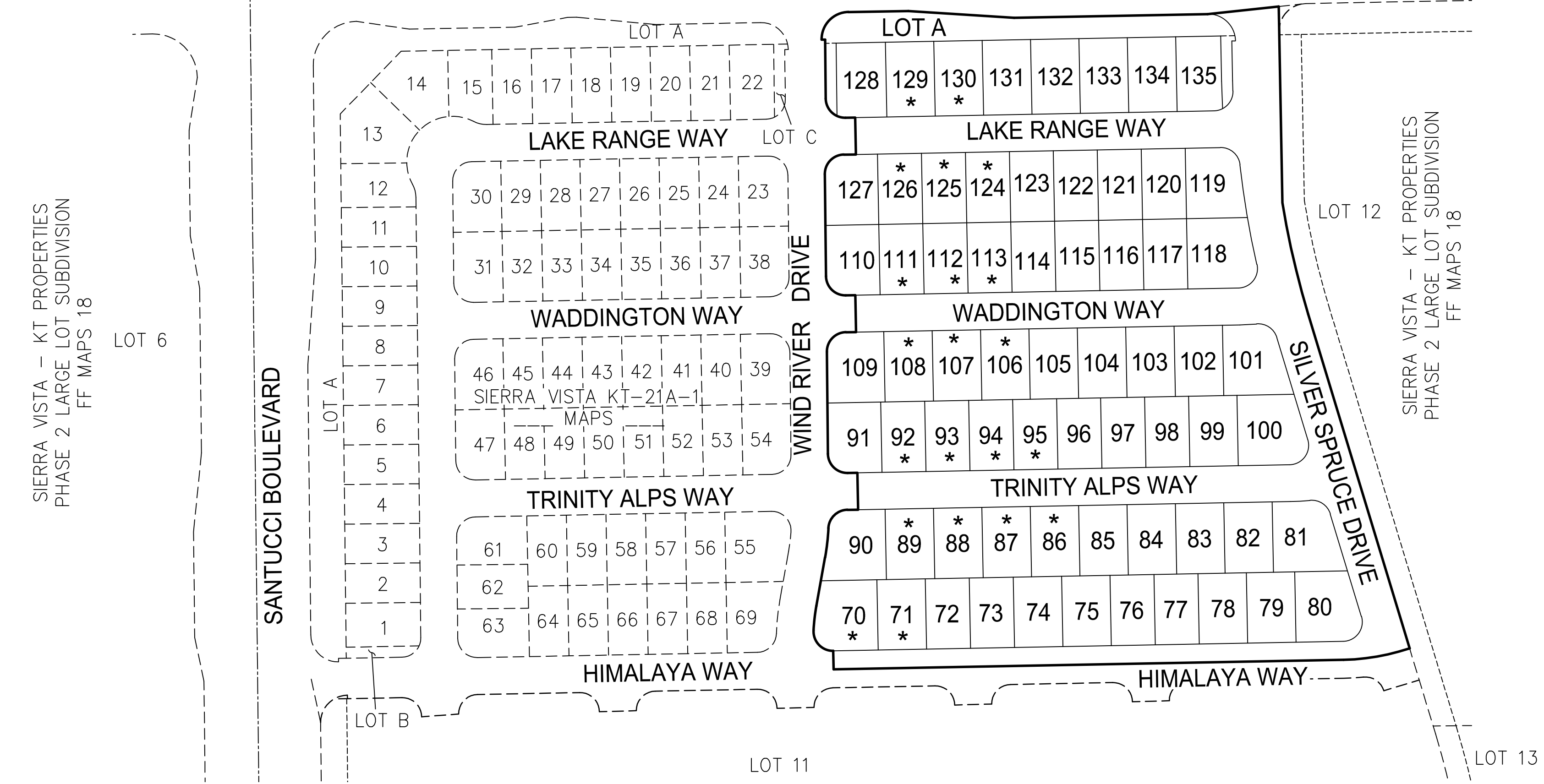

ADDITIONAL INFORMATION FOR INFORMATIONAL PURPOSE ONLY PURSUANT TO SECTION 66434.2 OF THE GOVERNMENT CODE

EACH RESIDENTIAL DWELLING CONSTRUCTED ON ANY OF THE LOTS INDICATED SHALL BE FITTED WITH A SEWER BACKFLOW PREVENTER VALVE AS APPROVED BY THE CITY OF ROSEVILLE. IT SHALL BE THE RESPONSIBILITY OF THE OWNER OF SAID DWELLING TO MAINTAIN THE VALVE AND PREVENT DAMAGE FROM OCCURRING THERETO. THE CITY OF ROSEVILLE SHALL NOT BE RESPONSIBLE FOR THE MAINTENANCE OR PERFORMANCE OF THE VALVE, AND THE CITY OF ROSEVILLE SHALL NOT BE LIABLE FOR ANY DAMAGE OCCURRING TO ANY SUCH DWELLING OR ITS CONTENTS DUE TO FAILURE OF THE VALVE FOR ANY REASON WHATSOEVER.

LEGEND

* DENOTES SEWER BACKFLOW PREVENTER VALVE REQUIRED ON SANITARY SEWER CONNECTION BY THE CITY OF ROSEVILLE WITH THE BUILDING PERMIT AND MAINTAINED THEREAFTER BY THE OWNER.

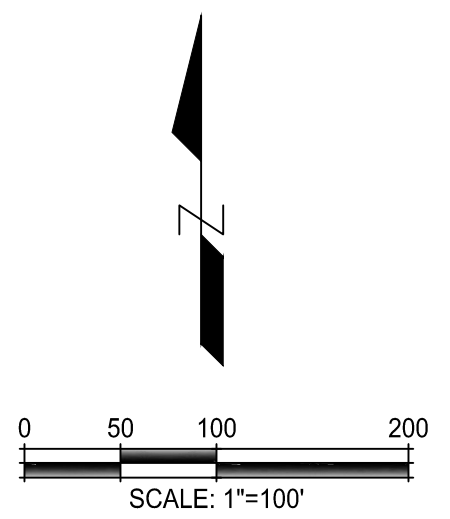

**FINAL MAP OF
SIERRA VISTA
KT 21A-2
SUBDIVISION No. PL17-0305**

BEING A SUBDIVISION OF REMAINDER LOT AS SHOWN AND SO DESIGNATED ON THAT CERTAIN FINAL MAP ENTITLED "SIERRA VISTA KT 21A-1", FILED FOR RECORD ON _____, 2021 IN BOOK _____ OF MAPS, AT PAGE _____, PLACER COUNTY RECORDS, SECTION 35, TOWNSHIP 11 NORTH, RANGE 5 EAST, MOUNT DIABLO MERIDIAN.

CITY OF ROSEVILLE • PLACER COUNTY • CALIFORNIA

R. E. Y. ENGINEERS, Inc.
Civil Engineers / Land Surveyors
905 Sutter St. Ste 200 Folsom CA 95630
(916) 366-3040 Fax (916) 366-3303

APRIL 2021