

FIDDYMENT F-25, F26
ROSEVILLE, CALIFORNIA

DIGITAL COLOR BOARDS

DECEMBER 4, 2020

CC Attachment 5 Exhibit D

SCHEME 1 - FARMHOUSE

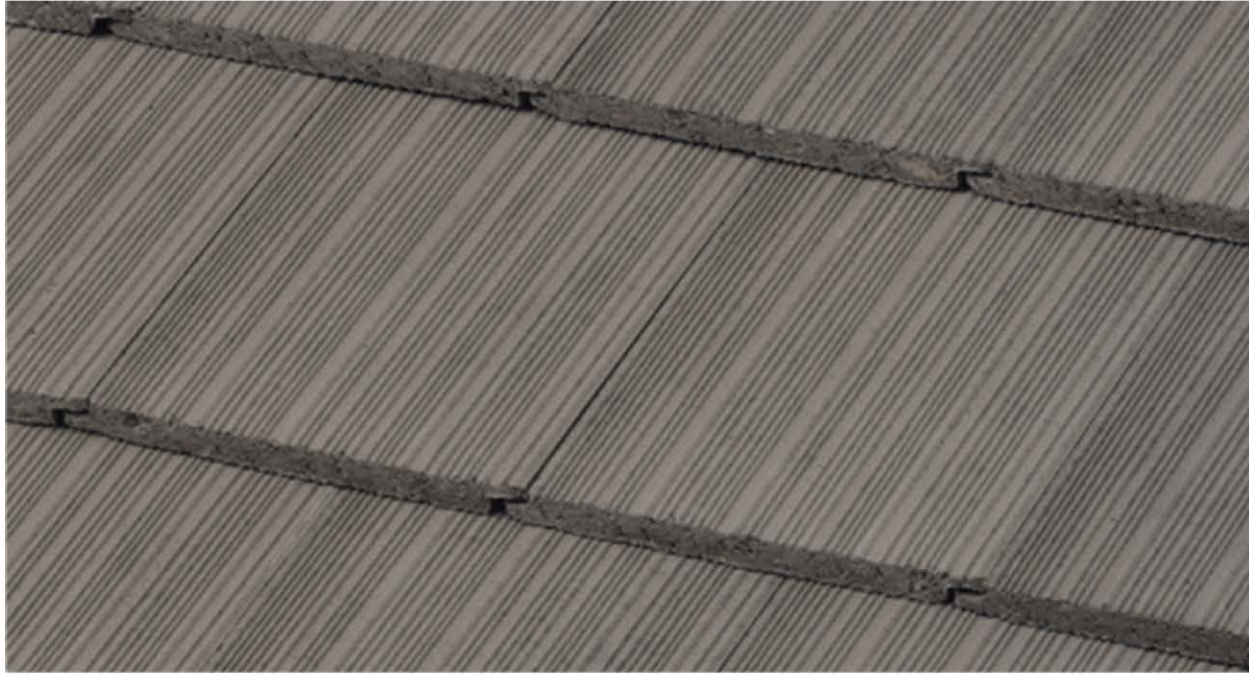

FLAT ROOF

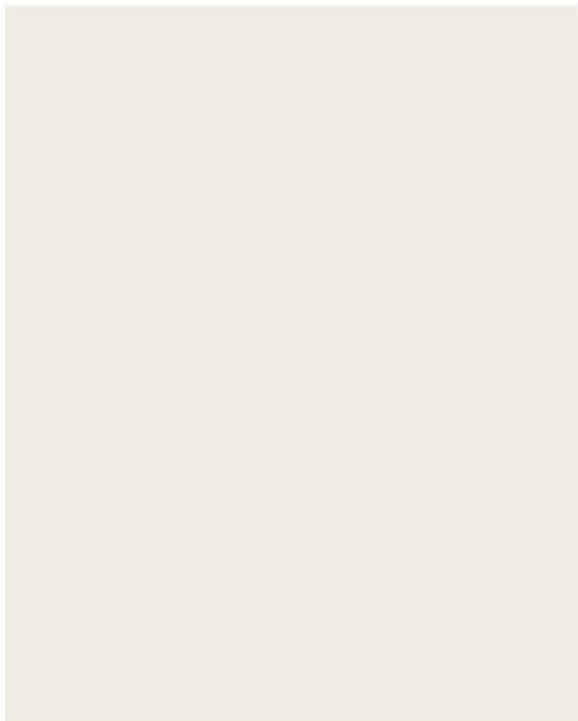

BASE STUCCO



FASCIA, EAVES, HEADERS, TRIM, SIDE & GARAGE DOOR



FRONT ENTRY DOORS



SIDING

CC Attachment 5 Exhibit D

SCHEME 2 - FARMHOUSE



FLAT ROOF

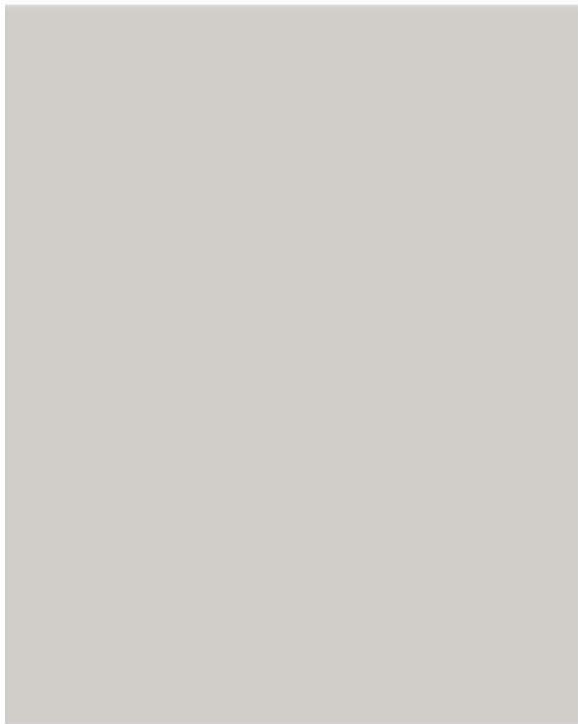

BASE STUCCO



FASCIA, EAVES, HEADERS, TRIM, SIDE & GARAGE DOOR



FRONT ENTRY DOOR S



SIDING

CC Attachment 5 Exhibit D

SCHEME 3 - FARMHOUSE

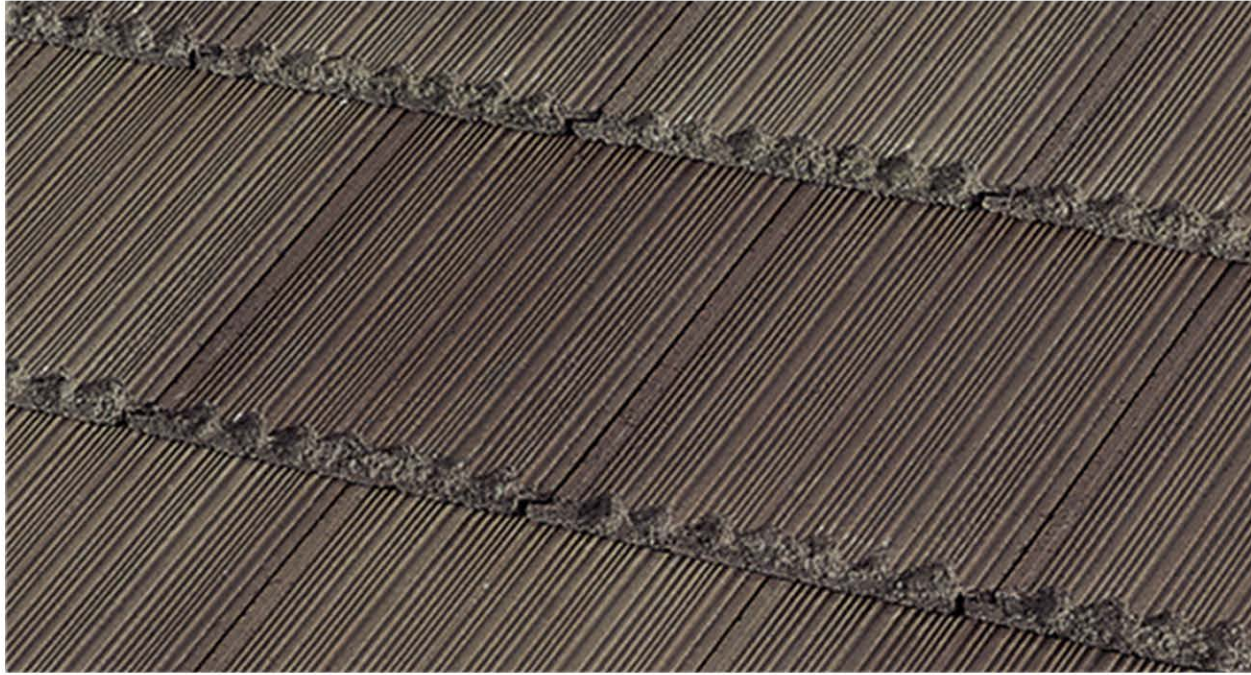

FLAT ROOF

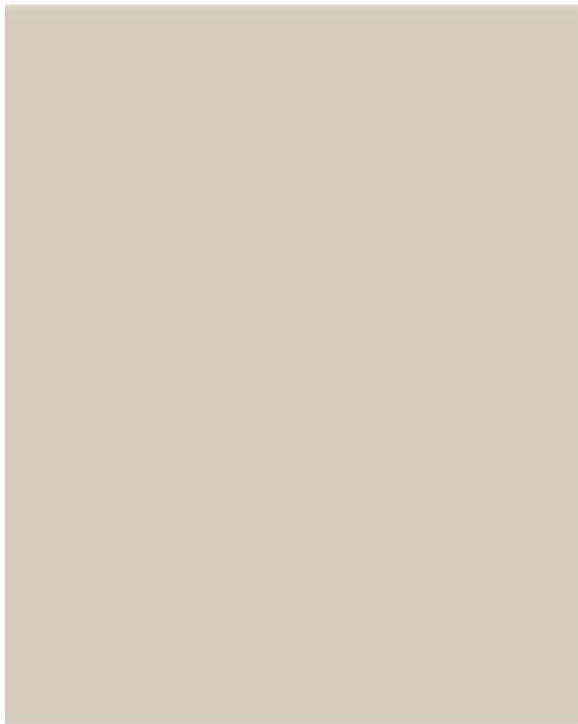

BASE STUCCO



FASCIA, EAVES, HEADERS, TRIM, SIDE & GARAGE DOOR



FRONT ENTRY DOORS



SIDING

CC Attachment 5 Exhibit D

SCHEME 4 - FARMHOUSE



FLAT ROOF

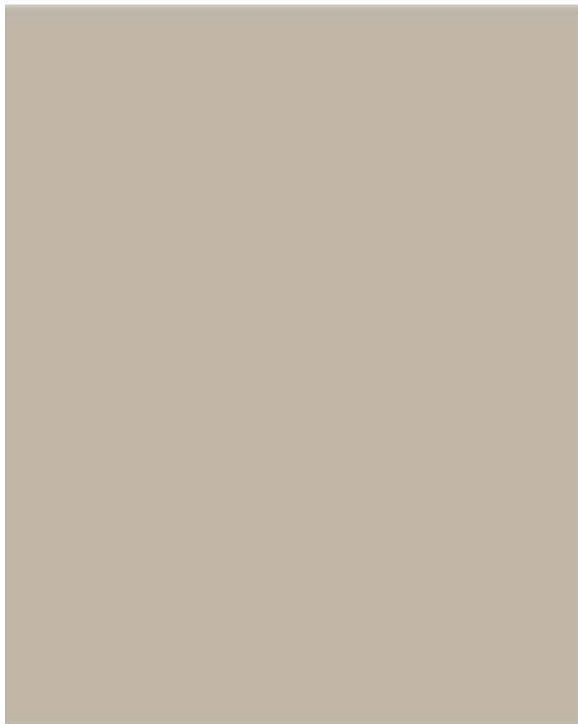

BASE STUCCO



FASCIA, EAVES, HEADERS, TRIM, SIDE & GARAGE DOOR



FRONT ENTRY DOORS



SIDING

CC Attachment 5 Exhibit D

SCHEME 5 - FARMHOUSE



FLAT ROOF

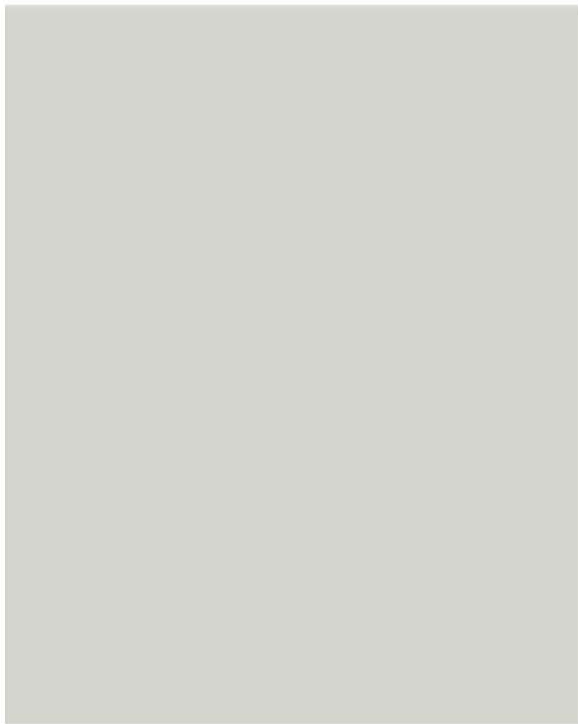

BASE STUCCO



FASCIA, EAVES, HEADERS, TRIM, SIDE & GARAGE DOOR



FRONT ENTRY DOORS



SIDING

CC Attachment 5 Exhibit D

SCHEME 6 - FARMHOUSE



FLAT ROOF

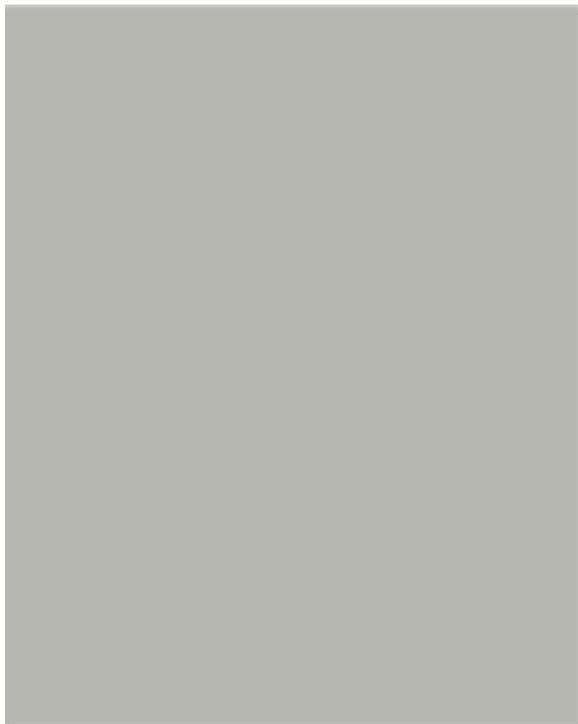

BASE STUCCO



FASCIA, EAVES, HEADERS, TRIM, SIDE & GARAGE DOOR



FRONT ENTRY DOORS



SIDING

PRELIMINARY ILLUSTRATIVE SITE PLAN FIDDYMENT RANCH F25-26

CITY OF ROSEVILLE

APRIL, 2021

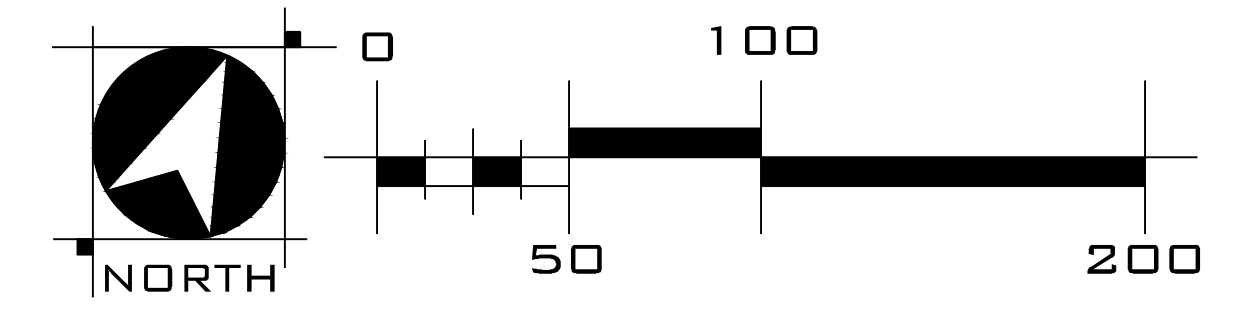

J:\1000-3\1027-Fiddyment Ranch\Phase2\F25-26\Landscape\Exhibits\Exhibit E-04-F-25-26.dwg 4/6/2021 12:43 PM Ashley Christensen

PRELIMINARY SHADE CALCULATIONS FIDDYMENT RANCH F25-26

CITY OF ROSEVILLE
APRIL, 2021

PLANT SCHEDULE

TREES	BOTANICAL / COMMON NAME	SIZE	WATER USE
	LARGE TREES		
	LIRIODENDRON TULIPIFERA / TULIP TREE	24" BOX	MEDIUM
	QUERCUS AGRIFOLIA / COAST LIVE OAK	24" BOX	LOW
	QUERCUS ILEX / HOLLY OAK	24" BOX	LOW
	MEDIUM TREES		
	ACER RUBRUM "ARMSTRONG" / ARMSTRONG RED MAPLE	24" BOX	MEDIUM
	QUERCUS RUBRA / RED OAK	24" BOX	MEDIUM
	TILIA GORDATA "GREENSPIRE" / LITTLELEAF LINDEN	24" BOX	MEDIUM
	ULMUS PARVIFOLIA / TRUEGREEN EVERGREEN ELM	24" BOX	MEDIUM
	SMALL TREES		
	ACER PALMATUM / JAPANESE MAPLE	24" BOX	MEDIUM
	ARBUTUS UNEDO / ARBUTUS STANDARD	24" BOX	LOW
	GINKGO BILOBA "AUTUMN GOLD" TM / AUTUMN GOLD MAIDENHAIR TREE	24" BOX	MEDIUM
	LAGERSTROEMIA X MUSKOGEE / CRAPE MYRTLE LIGHT LAVENDER MULTI-TRUNK	24" BOX	MEDIUM
	LAURUS NOBILIS / SWEET BAY	24" BOX	LOW
	MAGNOLIA STELLATA / STAR MAGNOLIA	24" BOX	MEDIUM
	ZELKOVA SERRATA "CITY SPRITE" / CITY SPRITE ZELKOVA	24" BOX	MEDIUM

PLANT SCHEDULE

GROUND COVERS (NOT SHOWN)	BOTANICAL / COMMON NAME	SIZE	WATER USE
SHRUBS AND GROUND COVER	ACACIA REDOLENS "LOW BOY" / LOW BOY BANK CATCLAW	5 GAL	LOW
	AGAVE ATTENUATA / FOXTAIL AGAVE	5 GAL	LOW
	ARCTOSTAPHYLOS U. "WOOD'S COMPACT" / WOOD'S COMPACT KINNIKINNICK	5 GAL	LOW
	CAMELLIA SASANGUA "SETSUGEKKA" / SETSUGEKKA CAMELLIA	5 GAL	LOW
	DIETES X "NOLA ALBA" / KATRINA AFRICAN IRIS	5 GAL	LOW
	FICUS PUMILA / CREEPING FIG	5 GAL	MEDIUM
	GREVILLEA X "NOELLI" / GREVILLEA	5 GAL	LOW
	JUNIPERUS HORIZONTALIS "WILTONII" / BLUE RUG JUNIPER	5 GAL	LOW
	LIRIOPE MUSCARI / LILYTURF	5 GAL	MEDIUM
	LOMANDRA LONGIFOLIA "BREEZE" TM / BREEZE MAT RUSH	5 GAL	LOW
	LOMANDRA LONGIFOLIA "PLATINUM BEAUTY" / PLATINUM BEAUTY MATT RUSH	1 GAL	LOW
	PHORMIUM TENAX "RUBRUM" / NEW ZEALAND FLAX	5 GAL	LOW
	PODOCARPUS MACROPHYLLUS "MAKI" / MAKI SHRUBBY YEW PODOCARPUS	5 GAL	MEDIUM
	PRUNUS CAROLINIANA "MONUS" / BRIGHT 'N TIGHT CAROLINA CHERRY LAUREL	5 GAL	LOW
	RHAPHIOLEPIS INDICA "CLARA" / CLARA INDIAN HAWTHORN	5 GAL	LOW
	ROSA X "FLOWER CARPET WHITE" / ROSE	5 GAL	MEDIUM
	SARCOCOCOA RUSCIFOLIA / FRAGRANT SARCOCOCOA	5 GAL	MEDIUM
	TRACHELOSPERMUM JASMINOIDES / STAR JASMINE	1 GAL	MEDIUM

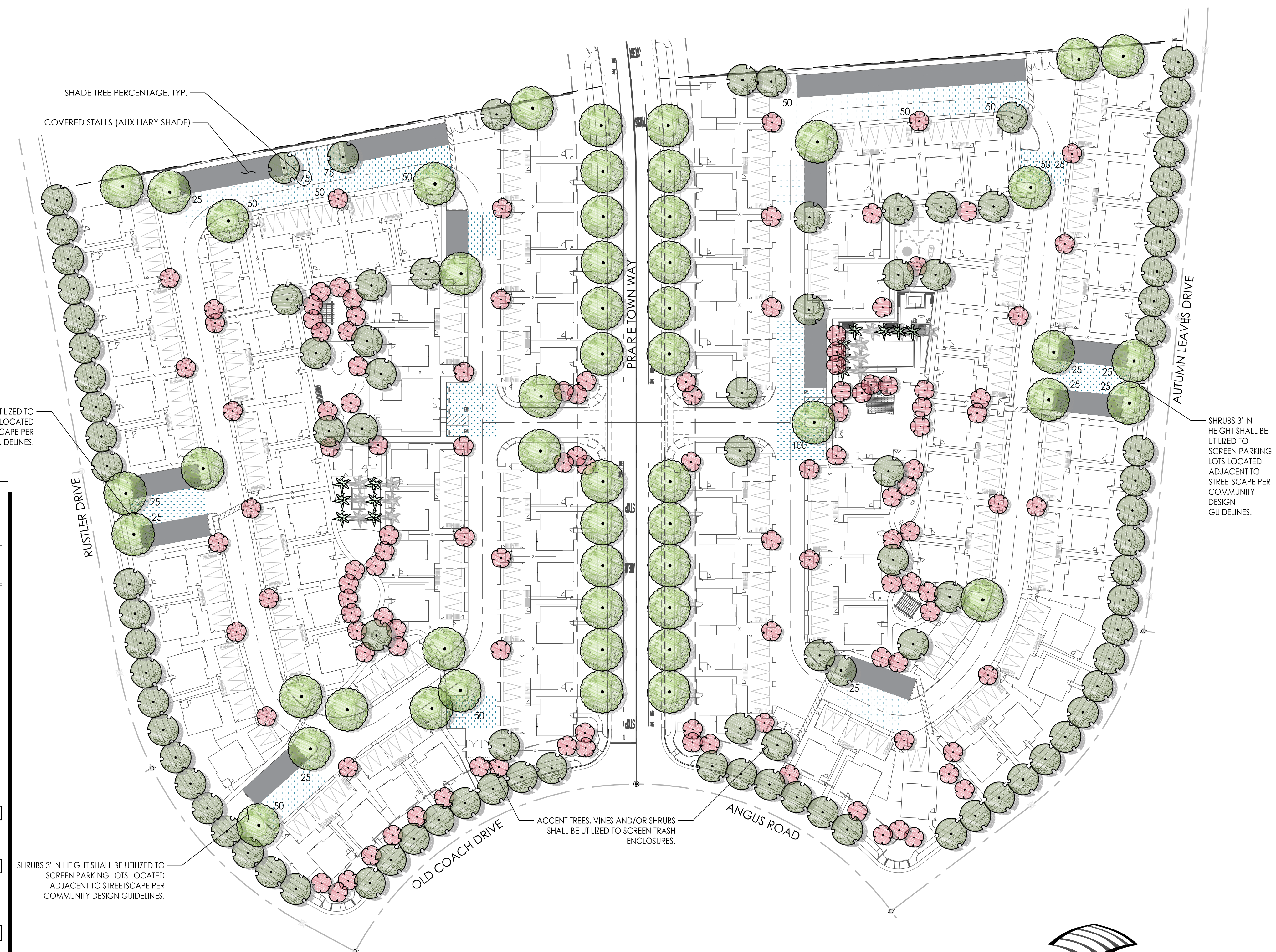

- ### LANDSCAPE PLAN NOTES
- ALL LANDSCAPE AREAS WILL UTILIZE LOW AND MEDIUM WATER USE PLANT MATERIAL AND LIMIT HIGH WATER USE PLANT MATERIAL.
 - ALL SHRUB AND GROUND COVER AREAS ARE TO RECEIVE A 3" LAYER OF BARK MULCH.
 - ACCENT TREES, VINES AND/OR SHRUBS SHALL BE UTILIZED TO SCREEN TRASH ENCLOSURES.
 - SHRUBS 3' IN HEIGHT SHALL BE UTILIZED TO SCREEN PARKING LOTS LOCATED ADJACENT TO STREETScape PER COMMUNITY DESIGN GUIDELINES.
 - IRRIGATION DESIGN SHALL COMPLY WITH CITY OF ROSEVILLE MODEL WATER EFFICIENT LANDSCAPE ORDINANCE. ALL NECESSARY DOCUMENTATION INCLUDING WATER CALCULATIONS AND CERTIFICATES SHALL BE SUBMITTED WITH THE LANDSCAPE CONSTRUCTION DOCUMENTS FOR REVIEW AND APPROVAL.
 - IRRIGATION SYSTEM WILL CONSIST OF LOW FLOW ROTARY SPRAY NOZZLE TECHNOLOGY, POINT SOURCE BUBBLERS AND/OR DRIP EMITTERS SYSTEM CONTROLLED BY AN AUTOMATIC IRRIGATION CONTROLLER USING ET DATA SCHEDULING AND RAIN SENSOR SHUT-OFF CAPABILITIES.
 - TOTAL OF 152 BICYCLE PARKING SPACES PROVIDED.

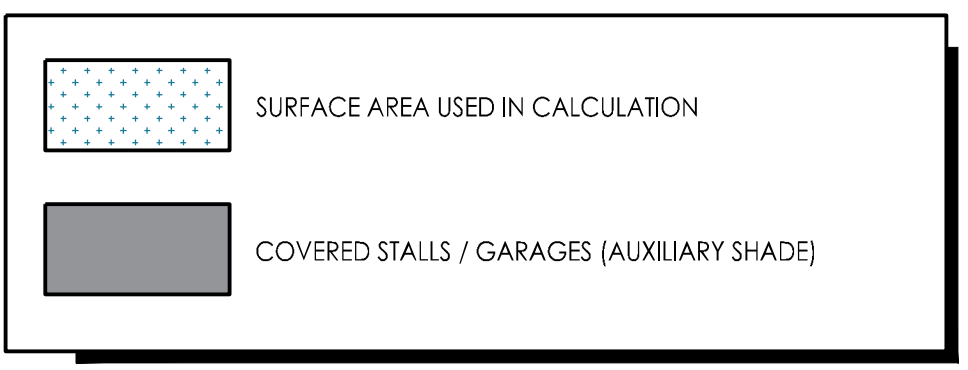

Preliminary Shade Calculation Fiddymment F25-26

ROSEVILLE, CALIFORNIA
Based on Preliminary Landscape Plan Dated February 2021

% (SHADE PERCENTAGE)	QUANTITY	SHADE AREA (SF)	AMOUNT (SF)
35' Diameter Trees			
100%:	1	962	962
75%:	0	722	0
50%:	5	481	2405
25%:	8	240	1920
25' Diameter Trees			
100%:	0	491	0
75%:	2	368	736
50%:	2	246	492
25%:	1	123	123
15' Diameter Trees			
100%:	0	177	0
75%:	0	133	0
50%:	2	89	178
25%:	1	44	44
TOTAL TREE SHADE AREA		6860	
SURFACED AREA			
PARKING LOT	27227		
COVERED STALLS	14907		
TOTAL SURFACED AREA		42134	
SHADE AREA REQUIRED		21067	
TOTAL AUXILIARY SHADE		14907	
TOTAL SHADE PROVIDED		21767	
TOTAL SHADE PERCENTAGE		51.66%	

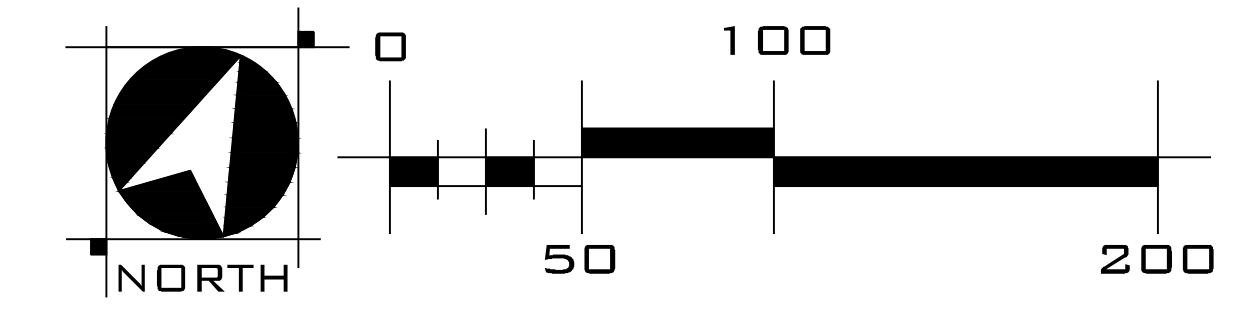

J:\000-3\1027-Fiddymment Ranch\Phase2\F25-26\Landscape\Exhibits\Exhibit E\SHADE-F25-26.dwg 4/6/2021 12:47 PM Ashley Christensen

AMENITY AREA ENLARGEMENTS FIDDYMENT RANCH F25-26

CITY OF ROSEVILLE
APRIL, 2021



Grass Mound Tunnel with Artificial Turf



Grass Mound Tunnel with Artificial Turf



Cabana with Seating and Planters



Stone Age Custom Corn Hole



Wood Accent Wall with Bench seating



Prefabricated Fountain at Focal Point



Bar Seating

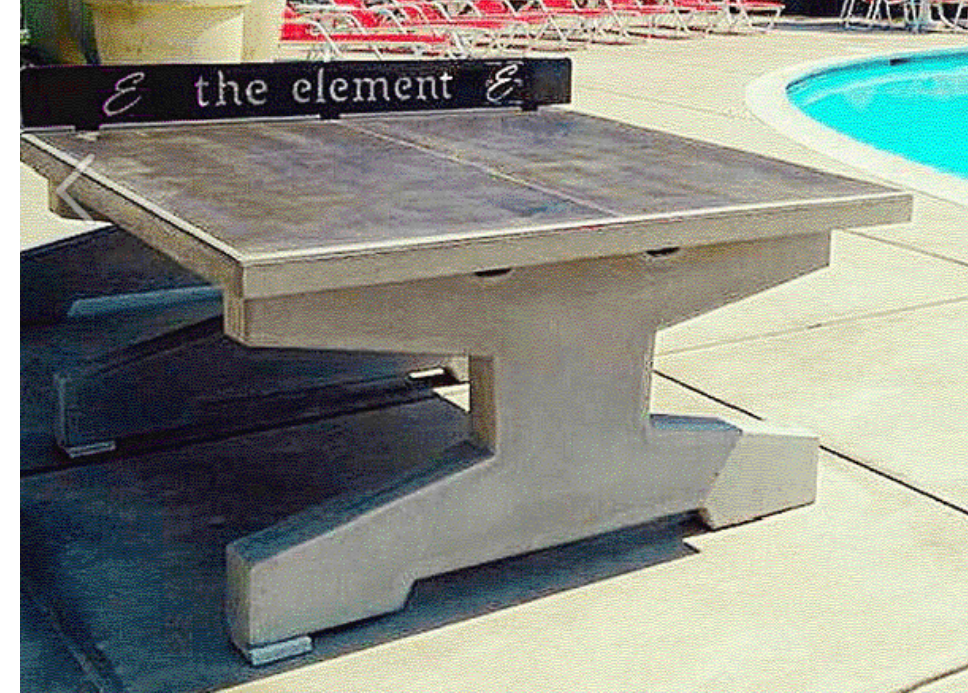

Stone Age Custom Ping Pong Table

- FREESTANDING GRILL
- OUTDOOR TABLE
- PICNIC TABLES
- SEAT WALLS
- SHADE STRUCTURE
- WASTE RECEPTACLE
- GRASSY MOUNDS
- BENCH UNDER PERGOLA

- TURF
- OUTDOOR RECREATION - PING PONG
- RAISED PLANTER AREA

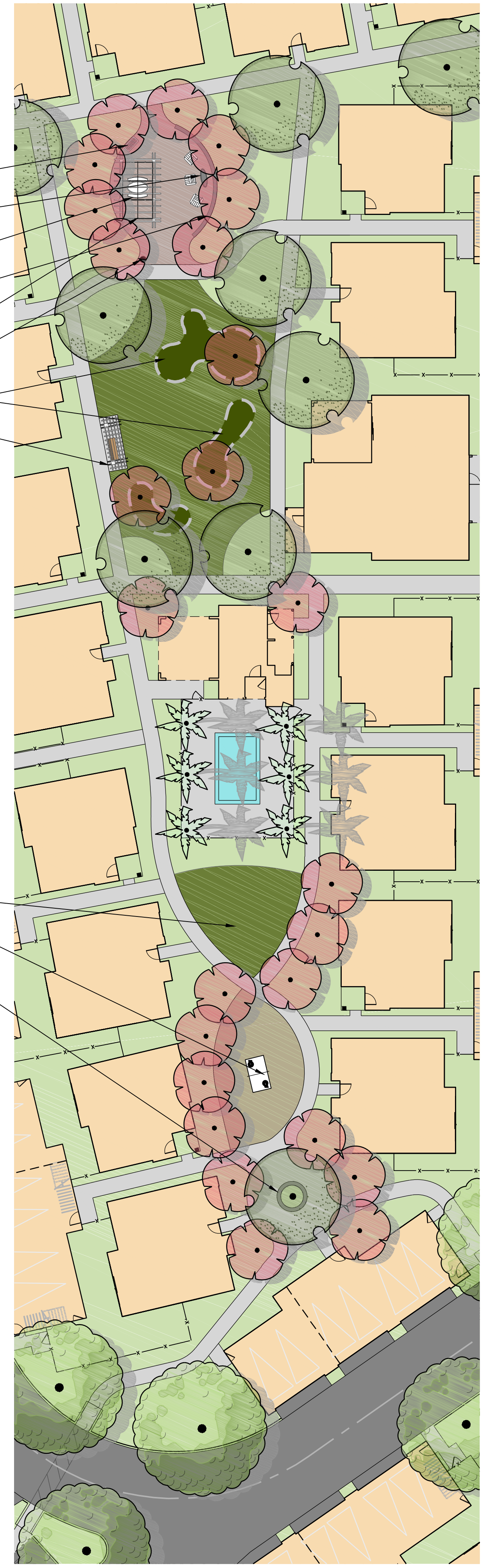

A WEST AMENITY AREA
1" = 20' PLAN



B EAST AMENITY AREA
1" = 20' PLAN

- SEAT WALLS
- SWINGS
- FALL ZONE, TYP.
- BENCH
- PLAY HOUSE
- ROPE SPINNER
- SEAT WALL
- PING PONG
- WOOD ACCENT WALL WITH WOOD BENCH SEAT
- 165 S.F. SPA
- SEATING AREA INCLUDING SOFA, CHAIRS, FIRE TABLE, AND POTS
- CABANA WITH LOUNGE SEATING
- TURF
- 1,066 S.F. POOL
- PALM TREE PLANTER
- SEATING AREA
- GLASS FENCED IN COURTYARD - POOL ACCESS, WITH FOCAL FOUNTAIN OR ART, BAR SEATING, ENHANCED PAVING
- COVERED COURTYARD WITH FIRE PLACE, SEATING, AND ENHANCED PAVING
- OUTDOOR RECREATION - CORN HOLE
- SEAT WALLS
- TURF
- WASTE RECEPTACLE
- FREESTANDING GRILL
- PICNIC TABLES
- SHADE STRUCTURE



SWINGS



ROPE SPINNER



PLAYHOUSE



Shade Structure with Retractable Fabric Panels

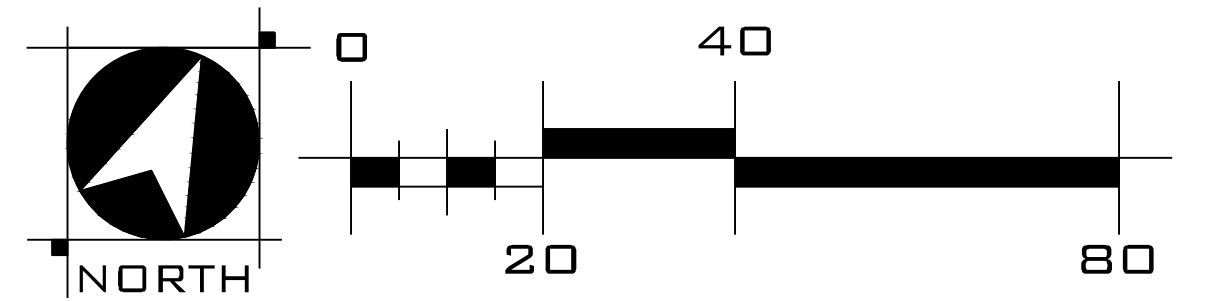

WOOD RODGERS
BUILDING RELATIONSHIPS ONE PROJECT AT A TIME
3301 C St, Bldg. 100-B Tel 916.341.7760
Sacramento, CA 95816 Fax 916.341.7767
SHEET 3 OF 6









J:\000-3\1027-Fiddymment Ranch\Phase2\F25-26\Landscape\Exhibits\EXHIBIT E-ENLARGEMENTS-F25-26.dwg 4/16/2021 12:50 PM Ashley Christensen

SITE AMENITY EXHIBIT

FIDDYMENT RANCH F25-26

CITY OF ROSEVILLE

APRIL, 2021

SITE FURNISHING SCHEDULE		
	BIKE RACKS	12 (PROVIDES 24 PARKING SPOTS)
	SHADE STRUCTURES	3
	BARBEQUES	3 (2 FREESTANDING, 1 BUILT-IN)
	BENCHES / SEATING WALLS	6
	WASTE RECEPTACLES	3
	PICNIC TABLES	3
	OUTDOOR RECREATION	6
	MUTT MITT STATION	6

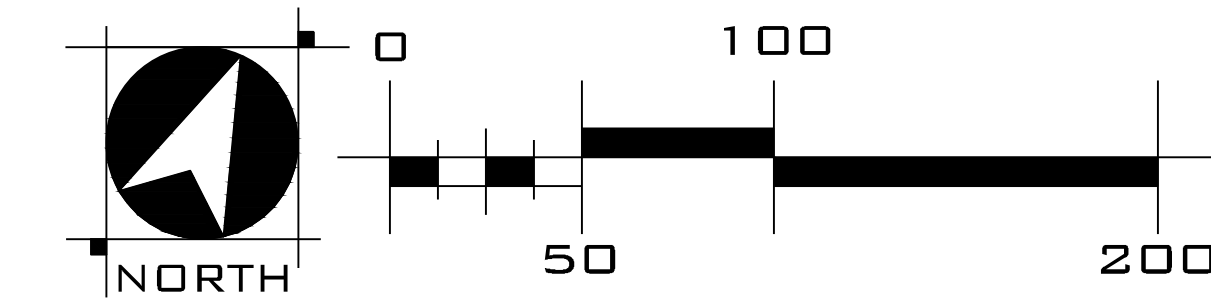

WOOD RODGERS
 BUILDING RELATIONSHIPS ONE PROJECT AT A TIME
 3301 C St, Bldg. 100-B
 Sacramento, CA 95816
 Tel 916.341.7760
 Fax 916.341.7767

J:\000-3\027-Fiddymment Ranch\Phase2\F-25-26\Landscape\Exhibits\Exhibit E\FIDDYMENT FURNISHING SCHEDULE-F-25-26.dwg 4/16/2021 12:52 PM Ashley Christensen

PROPOSED SITE FURNISHINGS

FIDDYMENT RANCH F25-26

CITY OF ROSEVILLE
APRIL, 2021



AEI Corporation PGS S27 Built-In Barbeque



AEI Corporation PGS T40 Freestanding Barbeque



Landscape Forms Glide Bench



Landscape Forms Lakeside Bench



Victor Stanley Lily Bench



Landscape Forms Loop Bike Rack



Landscape Forms Lakeside Trash Receptacle



QCP Arris Planter



Kornegay Design Agave Planter



Kornegay Design Mexbold Planter



Landscape Forms Lakeside Planter

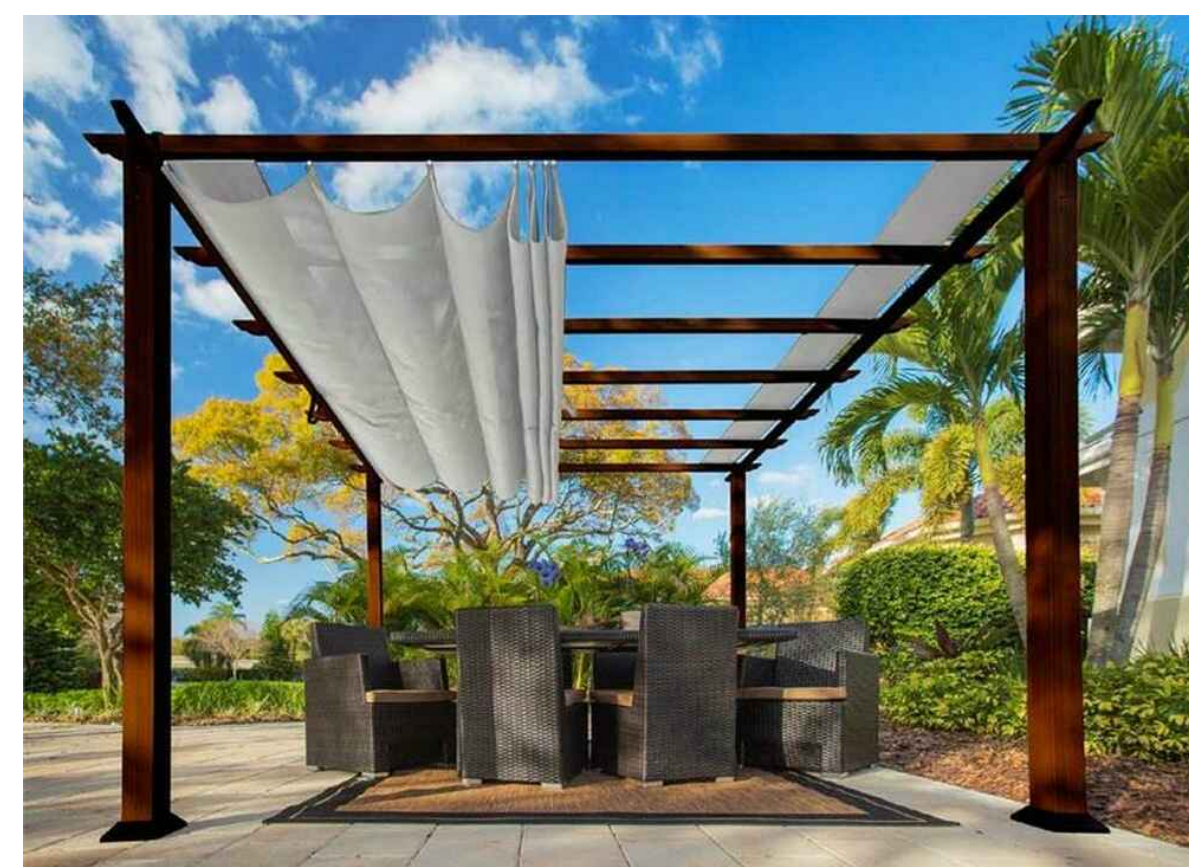

Shade Structure with Retractable Fabric Panels



Landscape Forms Harvest Table



Landscape Forms Catena Chair



Landscape Forms Americana Chair



Mutt Mitt Station

****IMAGES ARE REPRESENTATIVE OF DESIGN INTENT. FINAL PRODUCTS TO VARY**

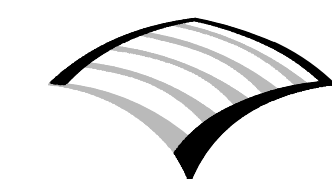

WOOD RODGERS
BUILDING RELATIONSHIPS ONE PROJECT AT A TIME
3301 C St, Bldg. 100-B Tel 916.341.7760
Sacramento, CA 95816 Fax 916.341.7767

PROPOSED DETAILS FIDDYMENT RANCH F25-26

CITY OF ROSEVILLE

APRIL, 2021

- KEY**
- 1x6" ALT. FENCE BOARD W/ 1" OVERLAP (BOARD-ON-BOARD). CUT TO MATCH FINISH GRADE
 - 4x4" PRESSURE TREATED POST AT 8' O.C. TYP.
 - 2x4" FENCE RAIL (TOP, MIDDLE & BOTTOM)
 - 1x4" FASCIA (PLANT-ON) BOARD AT TOP
 - 12x24" CONCRETE FOOTING SLOPED TO DRAIN
 - FINISH GRADE
 - UNDISTURBED NATIVE GRADE OR ENGINEERED FILL PER SOILS REPORT
 - 2x4" CAP RAIL
 - 1x6" FASCIA (PLANT-ON) BOARD AT BOTTOM
- NOTES**
1. ALL WOOD SHALL BE CONSTRUCTION GRADE REDWOOD OR CEDAR CONNECTED WITH HOT DIPPED GALVANIZED NAILS.
 2. PROVIDE SLOPED CUTS OF FENCE BOARDS TO ACCOMMODATE GRADE CHANGES.
 3. FENCE PANELS TO ALTERNATE

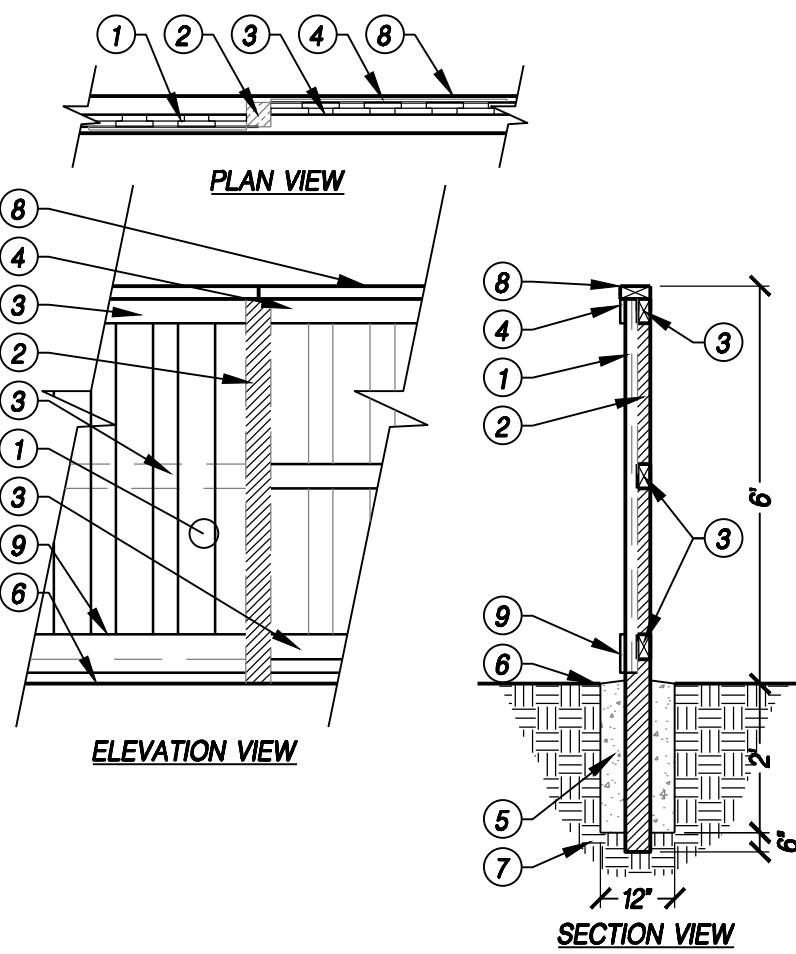

- KEY**
- 1 HINGE, TYPICAL
 - FINISH GRADE
 - 1x6" ALT. FENCE BOARD W/ 1" OVERLAP (BOARD-ON-BOARD)
 - 2x4" DIAGONAL BRACE
 - 4x4" PRESSURE TREATED POST, TYP.
 - GRAVITY LATCH
 - 2x4" HORIZONTAL BRACE
 - ADJACENT FENCE - SEE GOOD NEIGHBOR FENCE / ENHANCED FENCE DETAIL
- NOTES**
1. ALL WOOD EXCEPT FOR POSTS SHALL BE CONSTRUCTION GRADE REDWOOD OR CEDAR.
 2. ALL NAILS SHALL BE HOT DIPPED GALVANIZED.
 3. ALL POSTS TO BE P.T.D.F. GRADE B OR BETTER.
 4. CONCRETE FOOTING TO BE SLOPED TO ENSURE WATER RUNOFF.
 5. FENCE BOARD PANELS TO FACE STREET.
 6. GATES WIDER THAN 3'-0" REQUIRE 4x6" POST (HINGED SIDE ONLY).

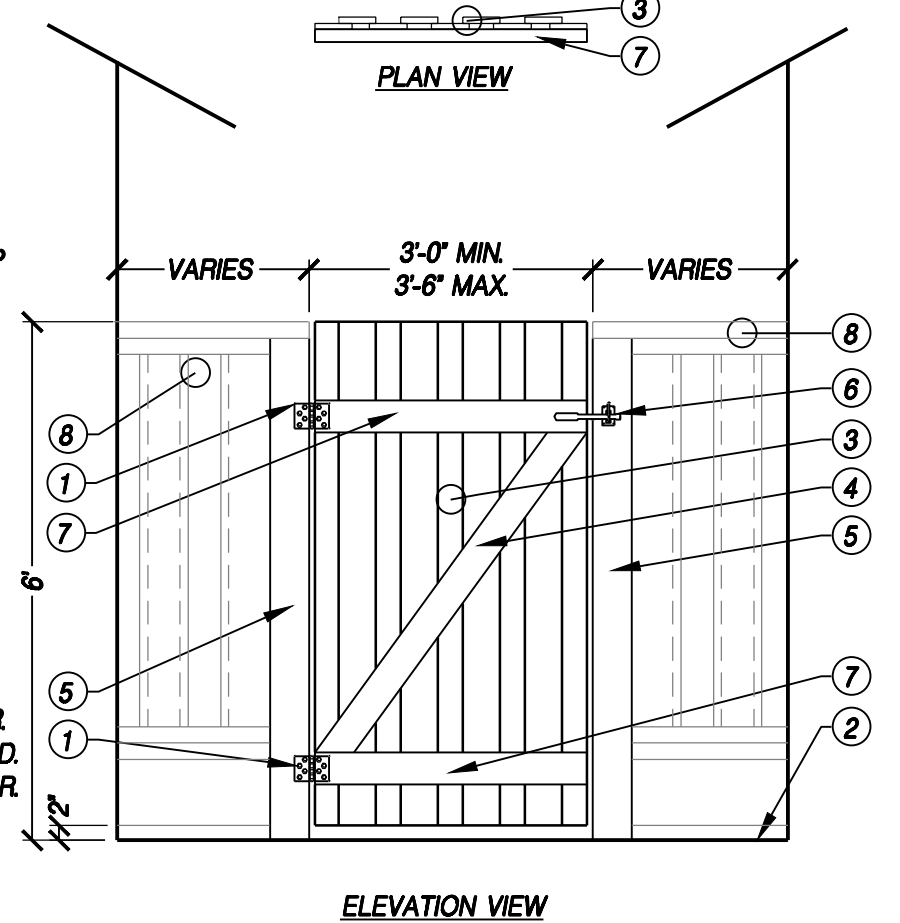

- KEY**
- 2' x 4' REDWOOD TOP RAIL
 - 4' x 4' REDWOOD POST
 - REDWOOD LATTICE PANEL (PERPENDICULAR PATTERN ONLY)
 - 1' x 1' REDWOOD MOLDING
 - 2' x 4' REDWOOD BOTTOM RAIL, TOE NAIL TO POST
 - FINISH GRADE
 - 12" DIAMETER PIER, SLOPE TO DRAIN
 - 1" DRAIN ROCK, 4" DEPTH
- NOTES**
1. ALL WOOD SHALL BE CONSTRUCTION HRT. RO. REDWOOD OR CEDAR #2 OR BETTER
 2. ALL HARDWARE SHALL BE HOT DIPPED GALVANIZED.
 3. SEE LAYOUT PLAN FOR MORE INFORMATION.

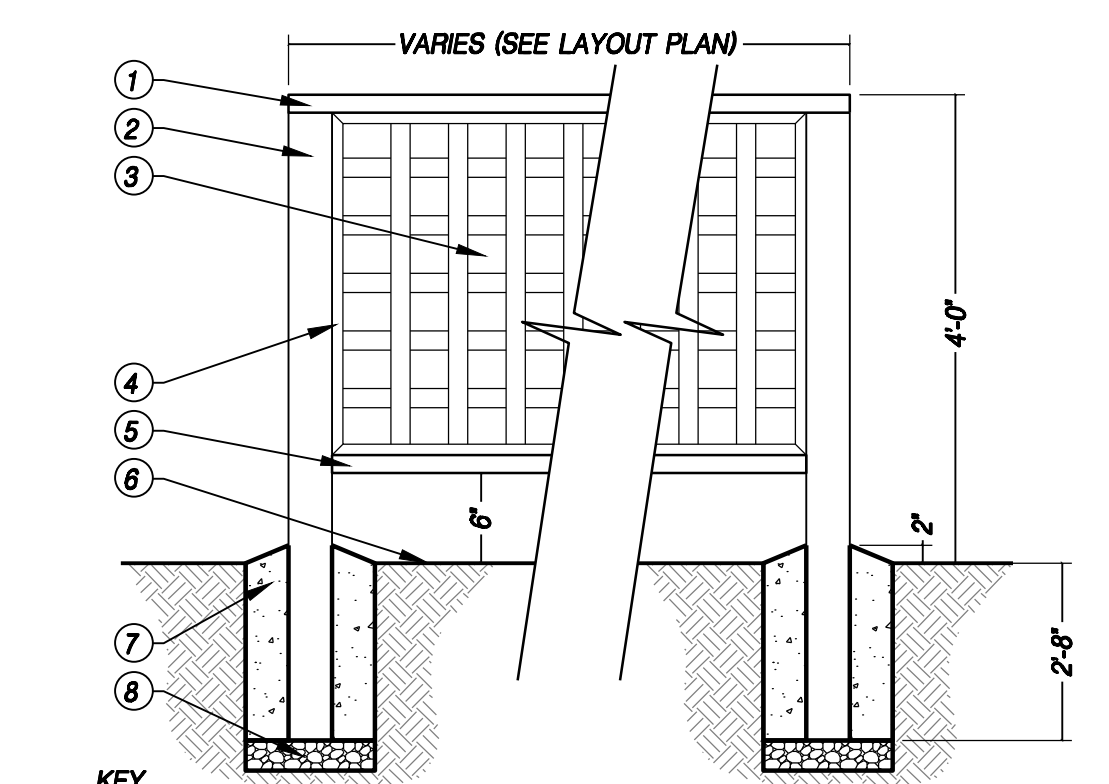

- KEY**
- 3" x 12 GA. POST
 - 1 3/4" x 14 GA. RAIL
 - 1" x 14 GA. PICKET
 - 18" x 30" CONCRETE FOOTING
 - COMPACTED SUBGRADE TO 90% R.D.
 - 4" AGGREGATE BASE, COMPACTED TO 95% R.D.
 - FINISH GRADE
- NOTES**
1. ALL FENCE PARTS TO BE TUBULAR STEEL. GRIND SMOOTH ALL WELDS.
 2. ALL METAL TO BE POWDERCOATED, COLOR: RAL #8017. CONTRACTOR TO SUBMIT SAMPLE TO LANDSCAPE ARCHITECT.
 3. FIELD VERIFY ALL DIMENSIONS PRIOR TO CONSTRUCTION.

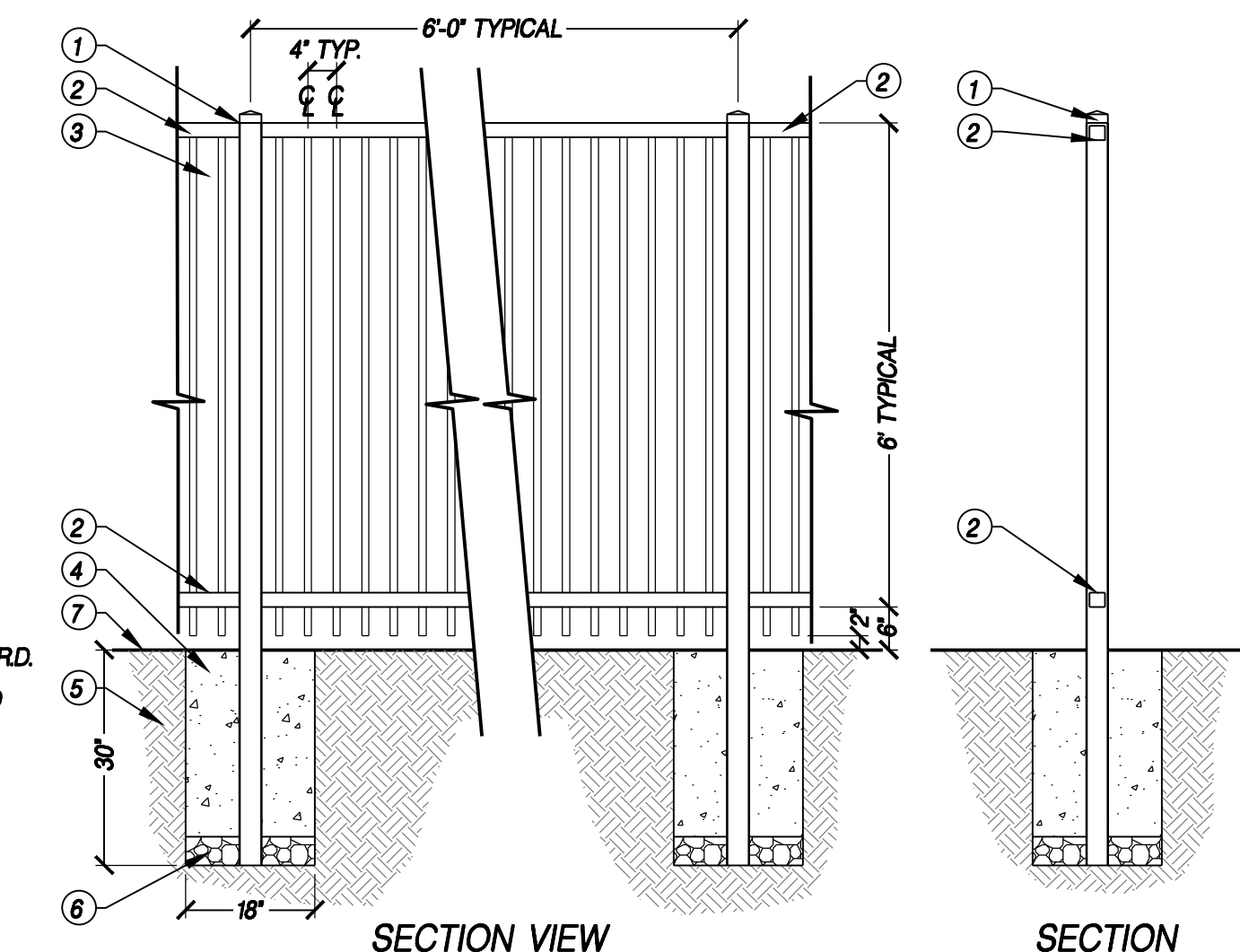

A GOOD NEIGHBOR WOOD FENCE (BOARD-ON-BOARD) NTS P-SW-01

B WOOD GATE (BOARD-ON-BOARD) NTS P-SW-02

C LATTICE PANEL FOR A/C UNIT NTS WR-LA-11

D 6" TUBE STEEL FENCE NTS WR-LA-FNC-07

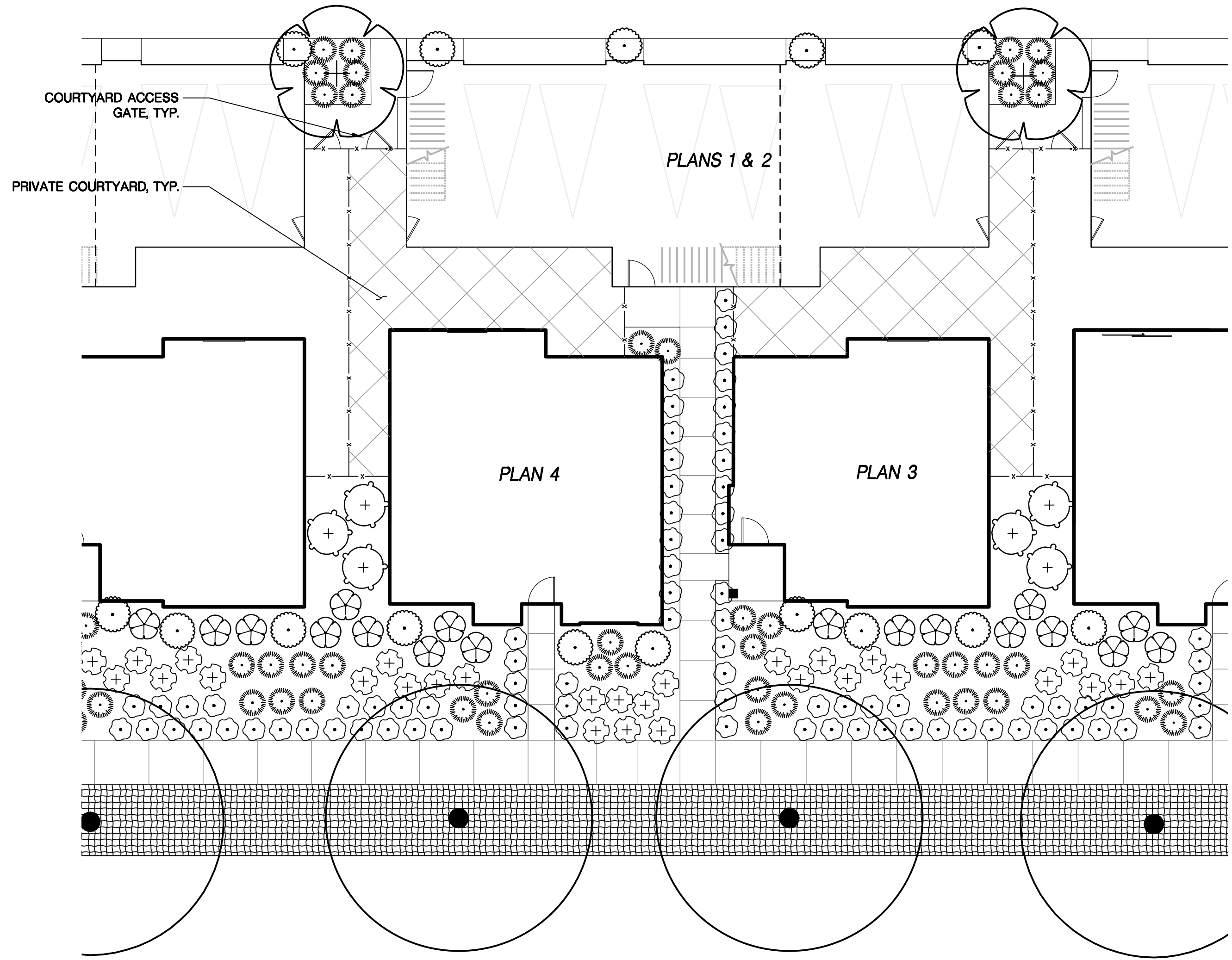

CONCEPT PLANT SCHEDULE

	ACCENT TREE ACER RUBRUM 'ARMSTRONG' / ARMSTRONG RED MAPLE CARPINUS BETULUS 'FASTIGIATA' / PYRAMIDAL EUROPEAN HORNBEAN GINKGO BILOBA 'FAIRMONT' / FAIRMONT MAIDENHAIR TREE QUERCUS ROBUR 'FASTIGIATA' / PYRAMIDAL ENGLISH OAK	15 GAL. MEDIUM 15 GAL. MEDIUM 15 GAL. MEDIUM 15 GAL. MEDIUM
	STREET TREE REFER TO PRELIMINARY SHADE CALCULATION PLAN	
	'A' / SMALL FOUNDATION SHRUB (ALTERNATE SP. PER LOT) DIETES X 'NOLA ALBA' / KATRINA AFRICAN IRIS EUONYMUS JAPONICUS 'MICROPHYLLA' / BOXLEAF EUONYMUS LOMANDRA LONGIFOLIA 'BREEZE' / DWARF MAT RUSH	5 GAL. LOW 5 GAL. LOW 5 GAL. LOW 1 GAL. LOW
	'B' / MEDIUM FOUNDATION SHRUB (ALTERNATE SP. PER LOT) MYRTUS COMMUNIS 'COMPACTA' / DWARF MYRTLE NANDINA DOMESTICA 'GULF STREAM' TM / HEAVENLY BAMBOO RHAPHIOLEPIS INDICA 'BALLERINA' / BALLERINA INDIAN HAWTHORN	5 GAL. LOW 5 GAL. MEDIUM 5 GAL. LOW
	'C' / LARGE SHRUB (ALTERNATE SP. PER LOT) PHORMIUM TENAX 'ATROPURPUREUM' / PURPLE NEW ZEALAND FLAX PRUNUS CAROLINIANA 'BRIGHT 'N TIGHT' TM / BRIGHT 'N TIGHT CAROLINA LAUREL XYLOSMA CONGESTUM / SHINY XYLOSMA	5 GAL. LOW 5 GAL. MEDIUM 5 GAL. LOW
	'D' / FOLIAGE ACCENT SHRUBS (ALTERNATE SP. PER LOT) BERBERIS THUNBERGII 'CRIMSON PYGMY' / CRIMSON PYGMY BARBERRY CALLISTEMON CITRINUS 'LITTLE JOHN' / DWARF BOTTLE BRUSH MULLENBERGIA CAPILLARIS / PINK MUHLY	5 GAL. LOW 5 GAL. LOW 5 GAL. LOW
	'E' / FLOWERING ACCENT SHRUBS (ALTERNATE SP. PER LOT) GAURA L. 'WHIRLING BUTTERFLIES' / WHIRLING BUTTERFLIES GAURA HEMEROCALLIS X 'MONOLD' TM / DOUBLE GOLD EVERGREEN DAYLILY PEROVSKIA ATRIPPLICIFOLIA / RUSSIAN SAGE	5 GAL. LOW 1 GAL. LOW 5 GAL. LOW
	'F' / TALL COLUMNAR SHRUB CALLISTEMON VIMINALIS 'SLIM' / BOTTLE BRUSH CUPRESSUS S. 'TINY TOWER' TM / TINY TOWER ITALIAN CYPRESS PODOCARPUS ELONGATUS 'ICEE BLUE' TM / ICEE BLUE YELLOW WOOD PODOCARPUS MACROPHYLLUS 'MAKI' / MAKI SHRUBBY YEW PODOCARPUS	15 GAL. LOW 15 GAL. LOW 15 GAL. MEDIUM 5 GAL. MEDIUM
	'GC' / GROUNDCOVERS 36" O.C. SPACING ARCTOSTAPHYLOS X 'EMERALD CARPET' / EMERALD CARPET MANZANITA CISTIS PULVERULENTUS 'SUNSET' / ROCKROSE MYOPORUM PARVIFOLIUM 'PROSTRATUM' / MYOPORUM	1 GAL. LOW 1 GAL. LOW 1 GAL. LOW

E TYPICAL BUNGALOW PLANTING 1=10

