



Buildings & Grounds Project Manual

Name of project:

Industrial 12kV
Underground Conversion

Department:

Electric

TABLE OF CONTENTS

	<u>Pagination Notation</u>
Notice to Contractors	NTC
Instructions to Bidders	INT
Proposal	PROP
Insurance Broker Information Packet	INS
General Conditions for Buildings and Grounds	GC
Supplemental Conditions	SC
Specifications	SPEC
Drawings	DRAW
Assembly Bill No. 626	AB 626

CITY OF ROSEVILLE

DEPARTMENT OF ELECTRIC

Name of Project: Industrial 12kV Underground Conversion

NOTICE TO CONTRACTORS

NOTICE IS HEREBY GIVEN THAT sealed Proposals will be received at the Office of the City Clerk, 311 Vernon Street, Roseville, California, until March 15, 2022 at 3:00 p.m. Late Proposals will be rejected. No exceptions.

The Proposals will be publicly opened and read by the City Clerk or designee of the City of Roseville at 3:05 p.m. on March 15, 2022 at the Office of the City Clerk located at 311 Vernon Street, Roseville California for the following project: Industrial 12kV Conversion.

A pre-bid meeting will be held per the instructions listed on the Public Purchase at <http://www.publicpurchase.com>.

A Project Manual, including all Contract Documents and the Proposal forms for bidding this project, may be obtained on-line from the City of Roseville's website at https://www.roseville.ca.us/business/procurement_services/bids_rfps. All communications relative to this project shall be conducted through Public Purchase.

Bids shall be submitted on the City's Proposal Forms included in the Project Manual, plainly endorsed with the Bidder's name together with signed acknowledgement of any and all addenda. Proposal Forms shall be securely sealed in a suitable envelope marked with the name and address of the Bidder, and marked in capital letters on the front and back of the envelope as

NTC - 1

follows:

[NAME OF PROJECT]

(Name of Bidder)

(Address of Bidder)

Whether mailed or personally delivered, all bids shall be addressed to the City of Roseville, Office of the City Clerk, 311 Vernon Street, Roseville, California, 95678.

Each bid must be accompanied by a Bid Guaranty in the form of a Certificate of Deposit, Certified or Cashier's Check, Bidder's Bond or Irrevocable Standby Letter of Credit in an amount equal to at least ten percent (10%) of the Bidder's Grand Total Price. The Bid Guaranty will be retained by the City and applied to any and all damages sustained by the City in the event that the successful Bidder fails or refuses to enter into the Contract awarded to it and to furnish all required bonds and Certificates of Insurance. The City intends to award the Contract to the lowest responsible Bidder based on the Grand Total Bid Price for all components of the Project. To the extent allowed by law, the City reserves the right to reject any and all bids and/or to waive any irregularities or informalities in any bid or in the bidding procedure. The City specifically reserves the right to not award the Contract after the opening of bids.

Any bid may be withdrawn at any time prior to the time fixed in the public notice for the deadline submission of bids only by written request for the withdrawal of the bid filed with the City Clerk. The request shall be executed by the Bidder or his or her duly authorized representative. The withdrawal of a bid does not prejudice the right of the Bidder to file a new bid by the submission deadline. Whether or not bids are opened exactly at the time fixed in the public notice for opening bids, a bid will not be received after the deadline submission of bids

nor may any bid be withdrawn after the time fixed in the public notice for deadline for submission of bids. Immediately following the deadline for submission of bids all bids shall become the property of the City of Roseville and the City is under no obligation to return bids.

Bids will be examined and reported to the City Council within sixty (60) business days after the bid opening. Except as permitted by applicable law, no Bidder may withdraw its bid for a period of sixty (60) business days after the date of bid opening. Each Bidder will be notified of any award of the Contract by the City.

The City will affirmatively ensure non-discrimination on the basis of one or more of the following: race, religious creed, color, national origin, ancestry, physical disability, mental disability, medical condition, genetic information, marital status, sex, age, sexual orientation, or military and veteran status in the award and administration of contracts that it awards.

Pursuant to Public Contract Code Section 22300, the successful Bidder may submit certain securities in lieu of the City withholding retention of payments during the Project.

The City has determined that the Contractor shall possess a valid Class A, General Engineering Contractor's license at the time that the bid is submitted, as well as any other license classification as may be required by the laws of the California for the performance of the work specified in the Contract Documents. Said license shall be maintained during the Contract period. Failure to possess the specified license shall render the bid nonresponsive and will act as a bar to the award of the Contract to any Bidder not possessing such a license at the time of bid submittal. The Contractor shall provide certification of the license, its number and the expiration date on the proposal form.

The work is to be done in Placer County. Pursuant to California Labor Code Section 1773, the City has ascertained the General Prevailing Rate of Wages in the County in which the

work is to be done to be as determined by the Director of Industrial Relations of the State of California. The Contractor is hereby made aware that information regarding prevailing wage rates may be obtained from the State Department of Industrial Relations and/or the following website address: <http://www.dir.ca.gov/dlsr/DPreWageDetermination.htm>. The Contractor is required to post a copy of the applicable wage rates at the job site. Attention is directed to Section 5 “Legal Relations and Responsibility” of the General Conditions.

Pursuant to Labor Code Section 1771.1(b), notice is hereby given that a contractor or subcontractor shall not be qualified to bid on, be listed in a bid proposal, subject to the requirements of Section 4104 of the Public Contract Code, or engage in the performance of any contract for public work, as defined in Labor Code Sections 1720, et seq., unless currently registered and qualified to perform public work pursuant to Labor Code Section 1725.5 or exempt from registration requirements pursuant to Labor Code Section 1725.5(f). It is not a violation of Labor Code Section 1771.1 for an unregistered contractor to submit a bid that is authorized by Section 7029.1 of the Business and Professions Code or by Section 10164 or 20103.5 of the Public Contract Code, provided the contractor is registered to perform work pursuant to Labor Code Section 1725.5 at the time the contract is awarded or is exempt from registration requirements pursuant to Labor Code Section 1725.5(f). The Contractor is hereby notified that this project is subject to compliance monitoring and enforcement by the Department of Industrial Relations.

All questions prior to the deadline for bid submissions shall be directed to Public Purchase at <https://publicpurchase.com>. The deadline for submissions of questions and clarifications regarding the Contract Documents is seven (7) calendar days before the deadline for

bid submissions. Only Addenda issued by the City are binding.

City Clerk, City of Roseville

Dated: _____

Published: _____

INSTRUCTIONS TO BIDDERS

SECTION 1. GENERAL

1-1.01 **GENERAL.** These Instructions to Bidders form a part of the Contract Documents. Capitalized terms are defined in the General Conditions Section 1.

1-1.02 **EXAMINATION OF PLANS, CONTRACT DOCUMENTS AND SITE OF THE WORK.** The Bidder shall examine carefully the site of the Work and all the Contract Documents, including these Instructions to Bidders, and shall inform itself of the conditions relating to the execution of the Work. Failure to do so will not relieve the successful Bidder of its obligation to enter into an Agreement and complete the Work in strict accordance with the Contract Documents. Conditions relating to the execution of the Work include the requirements of federal, state, and local laws, statutes and ordinances relative to the execution of Work, including, but not limited to, applicable regulations concerning prevailing wage rates, non-discrimination in the employment of labor, protection of the public, employee health and safety, and environmental protection.

The submission of a bid shall be conclusive evidence that the Bidder has investigated and is satisfied as to the conditions to be encountered, as to the character, quality, and scope of Work to be performed, the quantities of materials to be furnished, and as to the requirements of all the Contract Documents.

1-1.03 **EXISTING INFORMATION.** Where the Department has made investigations of site conditions, including subsurface conditions in areas where Work is to be performed under the Contract, such investigations are made only for the purpose of study and design. City does not represent that such conditions as found in these investigations or inferences or conclusions drawn as a result of these investigations will represent actual site

conditions and hereby disclaims any liability as a result of Contractor's or Bidder's reliance on such investigations. City will presume that all Bidders have conducted their own site investigations, including investigations of subsurface conditions. Where such investigations have been made, Bidders or Contractors may, upon written request, inspect the records of the Department as to such investigations subject to the conditions set forth in these Instructions to Bidders. Such inspection of records may be made only at the location noted above. The records of such investigations are not a part of the Contract Documents and are shown solely for the convenience of the Bidder or Contractor. The City assumes no responsibility whatsoever with respect to the sufficiency or accuracy of the investigations made, the records thereof, or of the interpretations set forth therein or made by the City in its use thereof. The City makes no warranty or guarantee, either express or implied, that the conditions indicated by such investigations or records are representative of those existing throughout such areas, or any part thereof, or that unforeseen developments may not occur, or that materials other than, or in proportions different from those indicated, may not be encountered.

No information derived from such inspection of records of investigations or compilation thereof made by the City, the Department or from the Engineer, or his or her assistants, will in any way relieve the Bidder or Contractor from properly examining the site and making such additional investigations as it may elect, or from properly fulfilling the terms of the Contract.

SECTION 2: BID REQUIREMENTS

2-1.01 **PROPOSAL FORMS.** The Department will furnish to each Bidder standard Proposal Forms, which, when filled out and executed may be submitted as the bid. Proposals shall include all pages in the Project Manual with page numbers marked “PROP” plus the Addendum acknowledgment form (front sheet) from all Addenda received by the Bidder. Proposals shall be removed from the Project Manual. The full Project Manual shall not be submitted with the proposal. Bids not presented on forms so furnished will be disregarded.

The Proposal and one (1) copy thereof shall be submitted as directed in the “Notice to Contractors” under sealed cover plainly marked as a Proposal, and identifying the project to which the Proposal relates and the date of the bid opening therefor. Proposals which are not properly marked may be disregarded.

All blank spaces in the Proposal must be completed, as required, in ink. All price information shall be shown, clearly legible, in figures where required.

The Bidder shall sign the Proposal in the blank space provided therefor. If the Bidder is the sole owner, the Proposal shall be signed by the owner. If the Bidder is a corporation, the legal name of the corporation and its State of incorporation shall be set forth and the Proposal shall be signed by at least two officers authorized to sign contracts on behalf of the corporation. If the Bidder is a partnership, the true name of the firm shall be set forth, the names and addresses of all partners shall be given and the Proposal shall be signed by a partner in the firm authorized to sign contracts on behalf of the partnership. If the Bidder is a joint venture, the Proposal shall be signed on behalf of each participating company by officers or other individuals who have the full and proper authorization to do so. If the Proposal is signed by an agent of the Bidder other than an officer of a corporation or a member of a partnership, a notarized Power of

Attorney must be on file with the City prior to opening of bids or must be submitted with the Proposal. If requested by the City, the Bidder shall promptly submit evidence satisfactory to the City of the authority of the person signing the Proposal.

2-1.02 **SUBMISSION OF BIDS.** Bids must be submitted at the prescribed time and location specified in the Notice to Contractors. Any submission received after the prescribed time shall be rejected, regardless of whether or not bids are opened exactly at the prescribed time.

Any unauthorized conditions or qualifications entered on, or changes made to, the Proposal may render it invalid and may cause its rejection.

No telegraphic, telephonic, or facsimile or other electronically transmitted bids will be considered.

2-1.03 **REQUIRED LISTING OF PROPOSED SUBCONTRACTORS.** Each Proposal shall list the name, address and Contractor license number of each Subcontractor to whom the Bidder proposes to subcontract portions of the Work in an amount in excess of one-half of one percent (0.5%) of its total bid, in accordance with Section 4100 to 4114, inclusive, of the Public Contract Code for the State of California. The Bidder shall list the Subcontractor's license number and the portion of the Work that will be done by each Subcontractor. If the Bidder fails to specify a Subcontractor for any portion of the Work, the Bidder agrees to perform that portion of the Work itself, and represents that it is qualified to perform that portion of the Work itself. The Bidder's attention is invited to other provisions of the Public Contract Code related to the imposition of penalties for a failure to observe its provisions by using unauthorized Subcontractors or by making unauthorized substitutions.

2-1.04 **CONTRACTOR'S LICENSING LAWS.** Attention is directed to the

provisions of Business and Professions Code Chapter 9 of Division 3 concerning the licensing of Contractors.

All Bidders at the time of bid submittal shall be licensed as Contractors in accordance with the laws of this State. Any Bidder or Contractor not so licensed is subject to the penalties imposed by such laws. The form of Contractor's license required is stated in the Notice to Contractors, provided that the City makes no representation as to whether the State may require other or additional licenses. It is the Bidder's and Contractor's responsibility to obtain the correct Contractor's licenses. Bidders shall be skilled and regularly engaged in the general class or type of Work called for under this Contract.

All Bidders and Contractors, including Subcontractors, shall have a current City business license before undertaking any Work.

2-1.05 **NONCOLLUSION DECLARATION.** By submitting a bid, the Bidder represents and warrants that such bid is genuine and not a sham or collusive or made in the interest or on the behalf of any person therein named, and that the Bidder has not, directly or indirectly, included or solicited any other Bidder to put in a sham bid, or any other person, firm, or corporation to refrain from bidding, and that the Bidder has not in any manner sought collusion to secure the Bidder an advantage over any other Bidder.

Bidders shall submit a properly completed and executed “Noncollusion Declaration” in the form required by Public Contract Code Section 7106 and provided with the Proposal (PROP-11).

2-1.06 **DISQUALIFICATION, REMOVAL OR OTHER PREVENTION OF BIDDING.** A bid may be rejected on the basis of a Bidder, any officer of such Bidder, or any employee of such Bidder who has a proprietary interest in such Bidder, having been disqualified,

removed, or otherwise prevented from bidding on, or completing a federal, state, or local project because of a violation of law or a safety regulation.

2-1.07 **PROPOSAL GUARANTY.** All bids shall be accompanied by one of the following forms of Bidder's security: Cash, a cashier's check, a certified check, or a Bidder's bond executed by an admitted California surety insurer, made payable to the City of Roseville, or any other form of security deemed acceptable by the City Attorney. The security shall be in an amount equal to at least ten percent (10%) of the amount bid. A bid will not be considered unless one of the form of Bidder's security is enclosed with it.

A Bidder's bond shall conform to the City's bond form in the Proposal and shall be properly filled out and executed.

2-1.08 **SCHEDULE OF BID PRICES.** Bidders are directed to submit unit and lump sum prices for all Work set forth in the Contract Documents on the Proposal Form entitled "Schedule of Bid Prices."

Unit prices and lump sum prices, as indicated, must be entered in the appropriate spaces provided in the Schedule of Bid Prices. If applicable, unit prices shall be multiplied by the quantities shown, and the total shall be inserted in the Amount column. In the event of any error or discrepancy between the unit price and the calculated amount, the unit prices shall govern.

The City may correct any mathematical errors apparent on the face of the bid.

The amounts shown in the Amount column must be added together in arriving at the Grand Total Bid Price.

Amounts for Allowance bid items must be entered in the exact amount in the Amount column.

The prices included within the Schedule of Bid Prices shall include all costs for labor,

materials, tools, equipment, services, Subcontractors, suppliers, taxes, insurance, shipment, delivery, overhead, profit, and all other costs necessary to perform the Work in accordance with the Contract Documents.

The Grand Total Bid Price shall be indicated in the Summary table form included with the Schedule of Bid Prices. The Grand Total Bid Price shall be the sum of the amounts bid for each of the designated portions of the Work, as more specifically described on the Schedule of Bid Prices form itself.

Full compensation for complying with the Contract Documents, including requirements of the Standard Specifications, the General Conditions, Supplemental Conditions, and all warranties, shall be considered included in the bid items and no additional compensation shall be allowed therefor.

Full compensation for completion of all work as shown on the plans, as specified in the Specifications, and as directed by the City, shall be considered included in the bid items and no additional compensation shall be allowed.

Bidders are strongly discouraged from submitting unbalanced bids. As used herein, the term “unbalanced bid” is defined as any bid that does not include a reasonable proportionate allocation of indirect costs and profit of each bid item indicated in the Schedule of Bid Prices. The City reserves the right to reject any unbalanced bid if the City determines that there is a reasonable doubt that an acceptance of the bid will not result in the lowest ultimate cost to the City with regard to the work or a disproportionate distribution of contract funds.

The City reserves the right to delete any bid item in its entirety and/or significantly reduce the quantity of Work under a bid item. The City makes no representation that any Work under a bid item will be performed during the course of the Project or that the Work will be

performed at the quantities included in the Schedule of Bid Prices. As provided in the General Conditions, for any deleted Work, Contractor shall not be entitled to payment of the indirect costs and profit included for said bid item. All bid items shall be considered distinct and severable from the remaining bid items, and each Bidder acts at its peril if its bid is unbalanced.

The City shall compare bids on the basis of the Grand Total Bid Price, which includes the base bid and any alternates designated on the Schedule of Bid Prices. Alternates may or may not be awarded, or may be awarded in any combination, at the City's discretion.

2-1.09 **WITHDRAWAL OF PROPOSALS.** Any bid may be withdrawn at any time prior to the time fixed in the Notice to Contractors for the opening of bids, provided that a request in writing, executed by the Bidder or its duly authorized representative, for the withdrawal of such bid is filed with the City Clerk. Facsimile and electronic mail requests are not acceptable. The withdrawal of a bid shall not prejudice the right of a Bidder to file a new bid. The withdrawal of any bid after the time fixed in the Notice to Contractors for the opening of bids will not be permitted.

2-1.10 **ADDENDUM.** Proposals shall include all costs and account for all Addenda issued prior to opening of bids. The Bidder is responsible for verifying that all issued Addenda have been received. An Addendum acknowledgment form for each Addendum shall be included as part of the Proposal submittal.

2-1.11 **PUBLIC OPENING OF PROPOSALS.** Proposals will be publicly opened and read at the time and place indicated in the Notice to Contractors. Bidders or their authorized agents are invited to be present.

2-1.12 **TRENCHING AND EXCAVATION WORK.** In accordance with the provisions of California Labor Code Section 6707, if the Work involves construction of a

pipeline, sewer, sewage disposal system, boring or jacking pits, or similar trenches or open excavations, which are five feet (5') or deeper, each bid submitted shall contain, as a bid item, adequate sheeting, shoring, and bracing, or equivalent method, for the protection of life or limb, which shall conform to all applicable safety orders.

SECTION 3: EVALUATION OF BIDS

3-1.01 **BID EVALUATION PROCESS.** Bids will be evaluated to determine the apparent low Bidder. The apparent low Bidder will be determined on the basis of the Grand Total Bid Price, as shown in the Schedule of Bid Prices. If additive or deductive alternates are used in the Schedule of Bid Prices, the apparent low Bidder will be the Bidder with the lowest total of the bid prices for base contract items plus the alternates designated by the City as those that will be used for determining the lowest bid price. However, the City reserves the right to (1) not award any alternates or (2) award any combination of alternates.

In case of discrepancy between the total of the base contract items and any specified alternates and the stated Grand Total Bid Price, the total of the base contract items plus specified alternates shall prevail. Any mathematical errors that appear on the face of the bid will be corrected by the City and the City will use the mathematically corrected addition. For example, if the mathematical total of Bidder's base contract items plus specified alternates equals \$1,000,000, but the Bidder has written \$1,250,000 as the Grand Total Bid Price, the City will consider \$1,000,000 to be the Bidder's Grand Total Bid Price for purposes of comparison to other Bidders and actual bid award. The City reserves its rights to reject or accept bids based on discrepancies between the stated Grand Total Bid Price and the actual mathematical total of the base contract bid items, plus specified alternates.

3-1.02 **REJECTION OF IRREGULAR PROPOSALS.** Proposals may be rejected in the City's sole discretion if they show any alterations of form, additions not called for, conditional bids, incomplete bids, erasures, or irregularities of any kind. However, the City reserves the right to waive any minor irregularities and informalities in any bid or in the bid procedure for any reason.

3-1.03 **COMPETITIVE BIDDING.** If more than one proposal is offered by any individual, firm, partnership, corporation, association, or any combination thereof, under the same or different names, all such proposals may be rejected. A party who has quoted prices on materials or Work to a Bidder is not thereby disqualified from quoting prices to other Bidders, or from submitting a bid directly for the materials or Work.

All Bidders are put on notice that any collusive agreement to control or affect the awarding of this Contract is in violation of the competitive bidding requirements of the City Charter, State Contract Act and the Business and Professions Code and may render void any Contract let under such circumstances.

3-1.04 **RELIEF OF BIDDERS.** If the Bidder claims a mistake was made in its bid, the Bidder shall give the Department written notice within five (5) Days after the opening of the bids of the alleged mistake, specifying in the notice in detail how the mistake occurred. No relief from a claimed mistaken bid shall be granted unless such mistake clearly appears on the face of the bid submitted to the City. Claimed mistakes on backup worksheets, spreadsheets, computerized bidding programs, or any other similar calculative bidding mistake which is not apparent on the face of the bid shall not under any circumstance be considered as a basis for relief. The burden of proving the occurrence of a mistake entitling a Bidder to relief from its bid rests entirely on the Bidder. Relief from bids shall be in the City's sole discretion.

SECTION 4: AWARD AND EXECUTION OF CONTRACT

4-1.01 **AWARD OF CONTRACT.** The City reserves the right to reject any and all proposals and to award (or not award) any combination of bid items at its option. Any such award will be to the lowest responsible Bidder whose proposal complies with the requirements prescribed for the bid items awarded. Such award, if made, will be made within sixty (60) business days after the opening of the proposals. If the lowest responsible Bidder refuses or fails to execute the Contract, or provide an acceptable Performance Bond, Payment Bond, and insurance certificate(s), the City may award the Contract to the second lowest responsible Bidder. Such award, if made, will be made within eighty-two (82) business days after the opening of proposals. If the second lowest responsible Bidder refuses or fails to execute the Contract, or provide an acceptable Performance Bond, Payment Bond, and insurance certificate(s), the City may award the Contract to the third lowest responsible Bidder. Such award, if made, will be made within one hundred four (104) business days after the opening of the proposals. The above time periods within which the award of Contract may be made are subject to extension for such further period as may be agreed upon in writing between the City and the Bidder concerned.

4-1.02 **RETURN OF BIDDER'S SECURITIES.** Within ten (10) Days after the award of the Contract, the City Clerk will return all Bidders' securities, other than Bidders' bonds, accompanying the proposals that are not to be further considered in making the award. Retained Bidders' securities will be held until the Contract has been fully executed, after which all Bidders' securities, except Bidders' bonds and any Bidders' securities that have been forfeited, will be returned.

4-1.03 **CONTRACT BONDS.** The successful Bidder shall furnish two (2)

bonds in the form contained in the section entitled Insurance Broker Information Packet and Bonds. One (1) bond shall secure the payment of the claims of laborers, mechanics or materialmen employed on the Work under the Contract, and the other bond shall guarantee the faithful performance of the Contract.

Each of the two (2) bonds shall be in a sum equal to one hundred percent (100%) of the Contract Price. If the Contract Price increases by the issuance of Change Orders, the penal amounts of the bonds required shall increase accordingly. Sureties on each of said bonds shall be satisfactory to the City.

All alterations, extensions of time, extra and additional Work, and other changes authorized by the Standard Specifications, the General Conditions, the Supplemental Conditions or any part of the Contract may be made without securing the consent of the surety or sureties on the Contract bonds.

Furthermore, the successful Bidder shall furnish a certificate from the County Clerk as required by California Civil Code of Procedure Section 995.660(a)(3).

4-1.04 **INSURANCE.** At the time of the execution of the Contract, the Contractor shall, at its own expense, procure, and at all times during the prosecution of the Work maintain in full force and effect Worker's Compensation Insurance, and Liability Insurance as specified in the General Conditions. The Contractor shall provide a Certificate of Insurance in the form contained in the section entitled Insurance Broker Information Packet.

4-1.05 **EXECUTION OF CONTRACT.** The Contract shall be signed by the successful Bidder and returned, together with all the required Contract bonds and insurance certificates, within fifteen (15) Days after the Contract has been awarded, or as otherwise directed, in writing, by the City.

If the Bidder is an individual, the Contract shall be executed personally by the Bidder. If the Bidder is a partnership, it is desirable that the Contract be executed by all of the partners, but it may be executed by one of them. If the Bidder is a corporation, it must be executed by two officers of the corporation consisting of (1) the chairman of the board, president or vice president; and (2) the secretary, assistant secretary, chief financial officer, treasurer or assistant treasurer, or by a person authorized by the corporation to execute written contracts on its behalf, and the corporate seal affixed thereto. In the alternative, a person other than an officer may sign the Contract, provided evidence satisfactory to the City is provided indicating the individual's authority to bind the corporation. If the corporate seal is not affixed to the Contract, or if it is executed by a person other than officers, or only by one officer, there must be attached to the Contract a certified copy of a resolution of the corporation authorizing such officer or person to execute written contracts for and on behalf of the corporation. If the Bidder is a joint venture, the Contract must be executed on behalf of each participating firm by officers or other individuals who have the full and proper authorization to do so.

4-1.06 **FAILURE TO EXECUTE CONTRACT.** Failure of the lowest responsible Bidder, the second lowest responsible Bidder, or the third lowest responsible Bidder to execute the Contract and file acceptable bonds and insurance as provided within fifteen (15) Days after the Contract has been awarded, or as otherwise directed, in writing, by the City, shall be just cause for annulment of the award and forfeiture of the Bidder's security. The successful Bidder may file with the City Clerk a written notice, signed by the Bidder or Bidder's authorized representative, specifying that the Bidder will refuse to execute the Contract if presented to Bidder. The filing of such notice shall have the same force and effect as the failure of the Bidder to execute the Contract and furnish acceptable bonds within the time prescribed.

SECTION 5: BID PROTEST PROCEDURES

5-1.01 **POLICY/PROCEDURES.** It is the policy of the City to consider fully and adjudicate promptly protests filed by prospective Bidders relating to the City's bidding procedure or award of the Contract. Protests shall be filed and processed in accordance with Section 4.12.150 of the Roseville Municipal Code. A Bidder's failure to follow the bid protest procedures may result in rejection of the protest by the City.

PROPOSAL TO THE DEPARTMENT OF _____

Project: _____

Name of Bidder _____ Business Phone _____

Business Address

_____ Place of Business

_____ Contractor's

License No. _____

License Expiration Date _____

License Classification Type _____

DIR Registration No. _____

Type of business organization: _____

*If a Corporation, incorporated under the laws of the State of: _____

City of Roseville Business License No.

The undersigned Bidder herewith submits this Proposal and binds itself on award by the City of Roseville under this bid to execute a Contract in accordance with its bid and the Contract Documents.

The Notice to Contractors, Instructions to Bidders, Form of Agreement, Specifications, General Conditions, Supplemental Conditions, Contract Drawings, and Addenda, if any, are made part of this bid and all provisions thereof are hereby accepted, and all representations and warranties are required thereby are hereby affirmed.

The work to be done is described in the Bidding Documents entitled _____, City of Roseville, California.

This offer shall be irrevocable for a period of sixty (60) Days after the date on which bids are opened.

The undersigned Bidder understands that any clarification made to the above or any new and different conditions or information submitted on or with its Proposal, other than that requested, may render the bid non-responsive.

The undersigned, as Bidder, declares that the only persons or parties interested in this Proposal as principals are those named herein; that this Proposal is made without collusion with any other person, firm, or corporation; that the Bidder has carefully examined the location of the proposed Work, the attached Form of Agreement, and the plans, Specifications, and other Contract Documents; and agrees if this Proposal is accepted, that it will contract with the City of Roseville, in the form of a copy of the Agreement contained in the Project Manual, to provide all necessary machinery, tools, apparatus and other means of construction, and to do all the work and furnish all the materials specified in the Contract Documents, in the manner and time therein prescribed, and according to the requirements of the Director, as therein set forth, and that the Bidder will take in full payment therefore prices indicated in the Schedule of Bid Items, including all work modified by addendum numbers _____. (IF NONE, STATE NONE).

Bids are required for all Bid Items. The amount of the Bid for comparison purposes will be the total of all items awarded.

The Bidder shall set forth for each item of work, in clearly legible figures, an item (“unit”) price and a total for the item in the respective spaces provided for this purpose in the Schedule of Bid Items.

The prices included within the Schedule of Bid Items include all costs for labor, materials, tools, equipment, services, Subcontractors, suppliers, taxes, insurance, shipment, delivery, overhead, profit, and for all other costs necessary to perform the Work in accordance

with the Contract Documents.

Accompanying this Proposal is _____.

(Notice: Insert the words “Cash \$_____,” “Cashier's Check,” “Certified Check,” or “Bidder's Bond,” as the case may be, in an amount equal to at least ten percent (10%) of the total of the Bid.)

The names of all persons interested in the foregoing Proposal as Principals, are as follows: _____

If SOLE OWNER, execute here:

I sign as sole owner of the business named above:

If PARTNERSHIP, one or more partners sign here:

The undersigned certify that we are partners in the business named above and that we sign this bid with the full authority to do so:

If CORPORATION, execute here:

Corporate Name: _____

Incorporated under the laws of the State of _____

The undersigned certify that they sign this bid with the full and proper authorization so to do:

By _____
*Signature of Authorized Official**

By _____
*Signature of Authorized Official**

Title

Title

Typewritten or Printed Name

Typewritten or Printed Name

If JOINT VENTURE, execute here:

Joint Venture name composed of: _____

The undersigned certify that they sign this bid with the full and proper authorization so to do:

*Signature of Authorized Official**

*Signature of Authorized Official**

Title

Title

Typewritten or Printed Name

Typewritten or Printed Name

*If Bidder is a partnership or Joint Venture, give the full names of all partners and/or Joint Ventures in the space provided (use additional sheet if required). If Bidder is a corporation, two signatures are required as follows: (1) the Chairman, President, or Vice-President and (2) the Secretary, Assistant Secretary, Chief Financial Officer, Treasurer, or Assistant Treasurer. In the alternative, this Agreement may be executed by a single officer or a person other than an officer provided that evidence satisfactory to City is provided demonstrating that such individual is authorized to bind the corporation (example, a copy of a certified resolution from the corporation's board or a copy of the corporation's bylaws).

[LIST OF SUBCONTRACTORS FOLLOWS ON NEXT PAGE.]

LIST OF SUBCONTRACTORS

Contractor's Name: _____

The Bidder is required to furnish the following information in accordance with the provisions of Section 4100 and 4114, inclusive, of the Public Contract Code of the State of California. This list and information shall include all Subcontractors that perform work, provide labor or render services to the Bidder in connection with the Project in an amount in excess of one-half of one percent (0.5%) of the total amount of the Bidder Grand Total Price.

PORTION/ TYPE OF WORK	% OF CONTRACT	SUB- CONTRACTOR'S NAME	CONTRACTOR LICENSE NO.	DIR REG NO.	BUSINESS ADDRESS (CITY, STATE)

SECURITY FOR COMPENSATION CERTIFICATE

(Required by California Labor Code Section 1861)

TO: City Council
City of Roseville

I am aware of the provisions of Section 3700 of the Labor Code which require every employer to be insured against liability for workers' compensation or to undertake self-insurance in accordance with the provisions of that code, and I will comply with such provisions before commencing the performance of the work of this Contract.

(Signature of Bidder)

Business Address

Telephone

BIDDER'S BOND

City Council of the City of Roseville

KNOW ALL MEN BY THESE PRESENTS:

That we _____
_____, as PRINCIPAL, and

a, _____ and duly authorized to transact business
under the laws of the State of California, as SURETY, are held and firmly bound unto the City of
Roseville in the penal sum of _____ dollars
(\$_____), being at least TEN PERCENT (10%) OF THE TOTAL AMOUNT OF
THE BID of the Principal above named, submitted by said Principal to the City of Roseville,
acting by and through the Public Works Director, for the work described below, for the payment
of which sum in lawful money of the United States, well and truly to be made, to the Director of
the Department to which said Bid was submitted, we bind ourselves, our heirs, executors,
administrators and successors, jointly and severally, firmly by these presents.

THE CONDITION OF THIS OBLIGATION IS SUCH,

That whereas the Principal has submitted the above-mentioned Bid to the City Council of
the City of Roseville, as aforesaid, for certain construction specifically described as follows, for
which Bids are to be opened at the Office of the City Clerk located at 311 Vernon Street,
Roseville, California, on _____, 20__ FOR

(Copy here the exact title of work as it appears on the Proposal.)

NOW, THEREFORE, IF THE AFORESAID PRINCIPAL is awarded the Contract and, within the time and manner required under the Contract Documents, after the prescribed forms are presented for signature, enters into a written Contract, in the prescribed form, in accordance with the Bid, and files all insurance and two (2) Bonds with the Department, one (1) to guarantee Faithful Performance and the other to guarantee Payment for Labor and Materials, as required by law, then this obligation shall be null and void; otherwise, it shall be and remain in full force and effect.

IN WITNESS WHEREOF, we have hereunto set our hands and seals on this ____ day of _____, 20__.

_____(Seal)

_____(Seal)

_____(Seal)

Principal

_____(Seal)

_____(Seal)

_____(Seal)

Surety

Business Address

NOTE: To be considered complete, both the Principal and the Surety must sign this Bidder's Bond. In addition, signatures of those executing for the Surety must be properly acknowledged.

Project _____

Contractor _____

SCHEDULE OF BID ITEMS

BID ITEM	ITEM DESCRIPTION	UNIT	TOTAL AMOUNT (\$)
1	Boring, conduit installation, Pull Box & Pad Vault Installation and all associated work for Industrial 12kV Underground Conversion	Lump Sum	

NONCOLLUSION DECLARATION TO BE EXECUTED BY
BIDDER AND SUBMITTED WITH BID

The undersigned declares:

I am the _____ of _____, the party making the foregoing bid.

The bid is not made in the interest of, or on behalf of, any undisclosed person, partnership, company, association, organization, or corporation. The bid is genuine and not collusive or sham. The Bidder has not directly or indirectly induced or solicited any other Bidder to put in a false or sham bid. The Bidder has not directly or indirectly colluded, conspired, connived, or agreed with any Bidder or anyone else to put in a sham bid, or to refrain from bidding. The Bidder has not in any manner, directly or indirectly, sought by agreement, communication, or conference with anyone to fix the bid price of the Bidder or any other Bidder, or to fix any overhead, profit, or cost element of the bid price, or of that of any other Bidder. All statements contained in the bid are true. The Bidder has not, directly or indirectly, submitted his or her bid price or any breakdown thereof, or the contents thereof, or divulged information or data relative thereto, to any corporation, partnership, company, association, organization, bid depository, or to any member or agent thereof, to effectuate a collusive or sham bid, and has not paid, and will not pay, any person or entity for such purpose.

Any person executing this declaration on behalf of a Bidder that is a corporation, partnership, joint venture, limited liability company, limited liability partnership, or any other entity, hereby represents that he or she has full power to execute, and does execute, this declaration on behalf of the Bidder.

I declare under penalty of perjury under the laws of the State of California that the foregoing is true and correct and that this declaration is executed on _____ [date], at _____ [city], _____ [state].

(Signature of Declarant)

DISQUALIFICATION QUESTIONNAIRE

The Bidder shall complete, under the penalty of perjury, the following questionnaire:

Has the Bidder, any officer of the Bidder, or any employee of the Bidder who has proprietary interest in the Bidder, ever been disqualified, removed, or otherwise prevented from bidding on, or completing a federal, state, or local government project because of a violation of law or a safety regulation?

Yes _____

No _____

If the answer is yes, explain the circumstances in the following space.

NAME OF BIDDER: _____

SIGNATURE OF BIDDER: _____

TITLE OF BIDDER: _____

DATE: _____

ACKNOWLEDGEMENT OF INSURANCE AND BOND REQUIREMENTS

Included in the Bid Price is full compensation for the requirements set forth in the INSURANCE BROKER INFORMATION PACKET of the Project Manual.

NAME OF BIDDER: _____

SIGNATURE OF BIDDER: _____

TITLE OF BIDDER: _____

DATE: _____

DISCLAIMER OF WARRANTIES AND ACCURACY OF DATA

Although soil and site investigation reports have been obtained from sources believed to be reliable, no warranty expressed or implied is made regarding accuracy, adequacy, completeness, legality, reliability or usefulness of any information contained therein. These reports are subject to change at any time, may be incomplete, and/or may contain errors. This information is provided for informational purposes only. The City of Roseville provides this information on an "as is" basis. Warranties of any kind, express or implied, or statutory, including but not limited to the implied warranties of merchantability, and fitness for a particular purpose ARE DISCLAIMED to any party viewing these documents or to any third party.

The City of Roseville does not accept and expressly disclaims liability to any party viewing such information, or to any third party whatsoever, for any loss, damage, or injury (including incidental or consequential damages) whether such loss, damage, or injury is the result of negligence, willful or intentional misconduct, or any other cause.

I have read and acknowledged the above disclaimer and agree to hold harmless the City of Roseville on any theory of liability for any loss, damage or injury whether in contract, strict liability or tort arising in any way out of the use or contents of the released information or documents described above or the performance of the work called for herein.

Print Name

Signature

Name of Business/Company/Corporation

Date

Address

Phone

END OF PROPOSAL

A G R E E M E N T

THIS AGREEMENT, is made and entered into this ____ day of _____,
20____, by and between the City of Roseville, a municipal corporation, (“CITY”), and
_____, a _____,
 (“CONTRACTOR”); and

W I T N E S E T H:

WHEREAS, the City Council of the CITY, at a meeting held on the ____ day of
_____, 20____, approved plans and specifications for the

and directed the City Clerk to advertise for sealed proposals for doing said work and providing
that bids be submitted on the ____ day of _____, 20____; and

WHEREAS, the City Clerk, thereafter duly and regularly caused a notice to be published
in the manner and for the time prescribed by law; and

WHEREAS, CONTRACTOR, pursuant to the provisions of said notice duly filed a bid
with the City Clerk, a true copy of which bid is now on file in the office of the City Clerk, and is
hereby referred to and by this reference made a part hereof as fully as if set forth at length herein;
and

WHEREAS, all bids received pursuant to said notice were opened and examined and
publicly declared at the time specified in said advertisement for bids and at a meeting of the City
Council held on the ____ day of _____, 20____, the Council found and

declared the bid of CONTRACTOR to be the lowest responsible bid and thereupon awarded a contract to CONTRACTOR to do the work referred to in the aforementioned specifications.

NOW, THEREFORE, the parties agree as follows:

1. THE WORK. CONTRACTOR agrees:

a. To do the work and furnish all the labor, materials, tools, supplies, equipment, superintendence, insurance, and bonds required for the _____

in accordance with the Contract Documents (the Work).

b. To do and perform the Work contemplated hereby in a good and workmanlike manner under the direction of and to the satisfaction of the Director of Public Works of the City of Roseville.

2. PAYMENT. CITY shall pay CONTRACTOR _____ dollars (\$ _____) for the Work to be done under this Agreement in accordance with the Contract Documents.

3. CONTRACT DOCUMENTS. The complete Agreement between the parties hereto consists of the following documents:

a. The advertisement for bids (including the notice to bidders, instructions to bidders and proposals);

b. The accepted bid;

c. Plans and specifications (including general conditions, supplemental conditions, special provisions and construction details);

d. Bonds and insurance required by the specifications; and

e. This contract.

All documents specified above are intended to operate so that any work called for in any one and not mentioned in the other, or vice versa, is to be executed the same as if mentioned in all said documents.

4. LIQUIDATED DAMAGES. In the event CONTRACTOR does not complete the Work within the time specified, CONTRACTOR agrees that CITY will suffer damages. Inasmuch as the actual damages which would result from such breach by CONTRACTOR under this Agreement are uncertain, and would be impractical or extremely difficult to fix, CONTRACTOR agrees that it shall pay, or CITY shall deduct from CONTRACTOR’s fee, the amount of \$500 per day as liquidated damages, in the event of such delay.

5. TIME OF COMPLETION. Time is of the essence of this Agreement. CONTRACTOR shall complete all Work under the Contract Documents within _____ Days of the date of this Contract. CONTRACTOR shall begin work by the date specified in the “Notice to Proceed” letter and shall diligently prosecute all of the Work under this Contract in all parts and requirements as defined in the Contract Documents.

6. SERVICE OF NOTICE. Any notice required or permitted to be given under this Agreement shall be deemed given when (a) personally delivered to the recipient identified below; (b) mailed by registered or certified mail, return receipt requested, postage pre-paid, to the address specified below; or (c) sent by facsimile, with confirmation of receipt, to the facsimile number identified below.

CITY OF ROSEVILLE

CONTRACTOR

CITY may also act through either its architect or construction manager if CITY expressly gives notice to CONTRACTOR, in writing, that CITY's designee has authority to act for CITY in a specific capacity.

7. DISPUTES. Disputes arising from this Agreement will be determined in accordance with the Contract Documents and Public Contract Code Sections 10240-10240.13.

8. GOVERNING LAW. This Agreement shall be governed by and construed in accordance with the laws of the State of California.

9. INDEPENDENT CONTRACTOR. CONTRACTOR shall act as an independent contractor, and covenants and agrees that it will conduct itself consistent with such status, that it will neither hold itself out as, nor claim to be, an officer or employee of CITY by reason of this Agreement.

10. SUCCESSORS IN INTEREST. This Agreement shall be binding upon the heirs, successors, executors, administrators and assigns of the respective parties hereto.

11. MODIFICATION. This Agreement and each provision contained herein may be waived, amended, supplemented or eliminated only by mutual written agreement of the parties.

12. SEVERABILITY. If any of the provisions contained in this Agreement are for any reason held invalid or unenforceable, such holding shall not affect the remaining provisions or the validity and enforceability of the Agreement as a whole.

13. INTEGRATED AGREEMENT. This is an integrated agreement and contains all of the terms, considerations, understanding and promises of the parties. It shall be read as a whole.

14. CONTRACTORS LICENSE LAW. CONTRACTORS ARE REQUIRED BY LAW TO BE LICENSED AND REGULATED BY THE CONTRACTORS' STATE LICENSE

BOARD WHICH HAS JURISDICTION TO INVESTIGATE COMPLAINTS AGAINST CONTRACTORS IF A COMPLAINT REGARDING A PATENT ACT OR OMISSION IS FILED WITHIN FOUR (4) YEARS OF THE DATE OF THE ALLEGED VIOLATION. A COMPLAINT REGARDING A LATENT ACT OR OMISION PERTAINING TO STRUCUTRAL DEFECTS MUST BE FILED WITHIN TEN (10) YEARS OF THE DATE OF THE ALLEGED VIOLATION. ANY QUESTIONS CONCERNING A CONTRACTOR MAY BE REFERRED TO THE REGISTRAR, CONTRACTORS' STATE LICENSE BOARD, P.O. BOX 26000, SACRAMENTO, CALIFORNIA 95826.

IN WITNESS WHEREOF, the City of Roseville, a municipal corporation, has authorized the execution of this Agreement in duplicate by its City Manager and attestation by its City Clerk under authority of Resolution No. _____, adopted by the Council of the City of Roseville on the ____ day of _____, 20____, and CONTRACTOR has caused this Agreement to be duly executed.

CITY OF ROSEVILLE, a
municipal corporation

_____, a

BY: _____
DOMINICK CASEY
City Manager

BY: _____
its: _____

and

ATTEST:

BY: _____
its: _____

BY: _____
SONIA OROZCO
City Clerk

APPROVED AS TO FORM:

BY: _____
MICHELLE SHEIDENBERGER
City Attorney

APPROVED AS TO SUBSTANCE:

BY: _____

Print Name: _____

Title: _____

INSURANCE BROKER INFORMATION PACKET

Project: Industrial 12kV Underground Conversion

NOTICE TO CONTRACTOR:

For your convenience, this package contains the Requirements for Insurance and Bonds for this project, including the necessary City forms. You are required to return these forms in addition to the executed Contract within fifteen (15) calendar days after the award of the Bid, unless otherwise directed by City in writing. (See the Instructions to Bidders.)

Please insert the dollar amount of your accepted Bid into the blank on page INS-1 and present this entire package to your insurance broker if you are awarded the Bid.

TABLE OF CONTENTS

	<u>Page</u>
Notice to Insurance Broker	INS 1
Insurance Requirements	INS 2
Public Works Faithful Performance Bond	INS 10
Public Works Payment Bond	INS 13

NOTICE TO INSURANCE BROKER

Your client has been awarded a bid by the City Council of the City of Roseville to perform a public works project known as _____.
The Contract Conditions for that project require your client (“the Contractor”) to return certain evidence of insurance and bonds to the City Attorney of the City within fifteen (15) days after the Bid award, unless otherwise directed by the City in writing, or else the Bid award may be terminated and awarded to another company.

This package contains the information you will need as an insurance broker to provide the appropriate insurance and bonds to the City. The insurance coverages the Contractor needs are specified in the section entitled “Insurance Requirements.” Please note that, in addition to the insurance certificate itself, copies of several endorsements must be actually furnished.

Please refer to the Supplemental Conditions for modifications of the General Conditions, if any, and the requirements of this insurance packet.

Please use the standard City of Roseville Bond Forms provided in this package.

The Bonds required must each be in the penal amount of: \$_____.

Bonds must be sent to the following staff person:

Insurance documents must be provided using one of the following methods:

- a. By email to roseville@ebix.com and riskmanagement@roseville.ca.us
- b. By fax to (770) 335-5727 and (916) 774-5461

After using one of these methods, please **DO NOT** send the insurance certificate(s) by mail.

When forwarding the documents, please refer to the project name so that the documents can be matched with the Contract for which they are submitted.

Thank you.

INSURANCE REQUIREMENTS

The following sections are quoted from the General Conditions:

5-1.23 **INSURANCE COVERAGE.**

A. Evidence of Maintenance Required. The Contractor shall, at its expense, procure and at all times maintain in full force and effect at a minimum the insurance required by this section on all of its operations; and the Contractor shall not allow any Subcontractor to commence work until similar insurance required of the Subcontractor has been obtained and filed. An original Certificate of Insurance, and copies of all required endorsements, all in a form approved by the Risk Manager, evidencing all required coverage or policies shall be filed after the award of the bid and prior to approval of the Contract by the City Council. Contractor shall provide ten (10) days prior written notice to the City of any reduction of coverage limits or cancellation of the coverage or policies shall be given to the City of Roseville as Certificate holder.

B. Qualifying Insurers. With the exception of the State Compensation Insurance Fund, all required insurance policies shall be issued by companies acceptable to the City and licensed to do business in the State of California and who hold a current policy holders alphabetic and financial size category rating of not less than AVII according to the most recent issue of Best's Insurance Reports.

C. Insurance Required.

1. **Commercial General Liability (CGL):** Insurance Services Office Form CG 00 01 covering CGL on an “occurrence” basis, including products and completed operations with limits of no less than Two Million Dollars (\$2,000,000) per occurrence for bodily injury, personal injury and property damage for projects under One Million Dollars (\$1,000,000) and

limits of no less than Five Million Dollars (\$5,000,000) per occurrence for bodily injury, personal injury and property damage for projects over One Million Dollars (\$1,000,000). If a general aggregate limit applies, either the aggregate limit shall apply separately to this project or the general aggregate limit shall be twice the required occurrence limit.

The Commercial General Liability insurance shall include the following, copies of which shall be provided:

a. Inclusion of the City of Roseville, and its officers, agents, employees, and volunteers, as additional insureds (except for workers' compensation) as respects services or operations under the Contract. The additional insured endorsement for the general liability policy shall be at least as broad as the ISO CG 2010 10 01 combined with ISO CGL Endorsement CG 2037 10 01. Any other endorsement must be approved in writing by the City. Endorsements must include coverage for on-going and completed operations, which coverage shall be maintained for four (4) years following completion of the Project. Endorsements shall cover the City of Roseville, its officers, agents, employees, and volunteers.

b. The insurance shall provide coverage for claims by one insured against another insured and the policies shall not contain any cross-suits exclusions, cross-liability exclusions, or insured versus insured exclusions. The policies shall not contain any classification exclusions purporting to deny coverage for any work to be performed by Contractor or any of its Subcontractors.

c. Stipulation that the insurance is primary and noncontributory, as evidenced by a separate endorsement (CG 20 01 04 13 or an equivalent) or section of the policy, and that neither the City nor its insurers will be called upon to contribute to a loss.

d. Such insurance shall specifically cover the contractual liability of

the Contractor.

e. Any available insurance proceeds in excess of the specified minimum insurance coverage requirements and limits shall be available to the additional insureds. Furthermore, the requirements for coverage and limits shall be: (1) the minimum coverage and limits specified in this Agreement; or (2) the full coverage and maximum limits of any insurance proceeds available to the named insureds, whichever is greater.

f. Waiver of subrogation endorsement.

g. The Contractor shall furnish a certificate for the period covered.

2. **Automobile Liability:** Insurance Services Office Form Number CA 0001 covering Code 1 (any auto), or if Contractor has no owned autos, Code 8 (hired) and Code 9 (non-owned), with limits of no less than One Million Dollars (\$1,000,000) per accident for bodily injury and property damage.

3. **Workers' Compensation:** In accordance with the provisions of the California Labor Code, Contractor is required to be insured against liability for Workers' Compensation or to undertake self-insurance. Statutory Workers' Compensation and Employers' Liability of at least One Million Dollars (\$1,000,000) shall cover all Contractors staff while performing any work incidental to the performance of this Agreement.

4. **Professional Liability:** Professional Liability (Errors and Omission) Insurance appropriate to Contractor's profession, with a limit of liability not less than One Million Dollars (\$1,000,000) per occurrence or claim and Two Million Dollars (\$2,000,000) aggregate to cover all design and engineering services rendered by Contractor pursuant to the Agreement. Coverage must commence from the first day that Contractor or any of its Subcontractors provided any design or engineering services in connection with the Project.

5. **Builder's Risk/Course of Construction Insurance Is ____ OR Is Not**

X **Required by Risk Management:** The Contractor shall be responsible for all loss, damage or destruction whatsoever to the work called for by this Contract until the approval of a Notice of Completion or acceptance of the Work if no Notice of Completion is to be recorded.

The Contractor shall secure "All Risk" type of builder's Risk Insurance of the type covering one hundred percent (100%) of the value of the work performed under this Contract (the value is presumed to be the Contract amount unless otherwise stated in Supplemental Conditions) and all materials, equipment, or other items to be incorporated therein while the same are located at the construction site, a bonded warehouse, or its place of manufacture. At any time, the policy shall cover the value of the work completed. The policy shall cover hazards including the losses due to fire, explosion, hail, rain, lightning, flood (separate insurance as needed), vandalism, malicious mischief, wind, collapse, aircraft, and smoke.

The policies providing such insurance shall name the City as a loss payee as its respective interests may appear, and certified copies of such policies shall be filed with the City. The maximum deductible allowable under the Builder's All Risk policy shall be five percent (5%) of the Contract amount.

Builder's Risk Insurance is not required for coverage of losses in excess of five percent (5%) of the Contract amount for damages resulting from earthquake in excess of a magnitude of 3.5 on the Richter scale, or tidal waves. Coverage in the amount of five percent (5%) of the Contract amount for such losses is required.

6. **Pollution Coverage:** Contractor shall procure pollution liability coverage or other insurance covering claims for bodily injury or property damage arising out of the abatement, removal, storage, transportation, or other exposure to hazardous materials or

pollutants, in limits not less than Two Million Dollars (\$2,000,000). Contractor shall add the City and all parties required to be indemnified by Contractor as additional insured on all pollution liability policies.

7. **Higher Coverage Limits:** If Contractor maintains higher coverage limits than the amounts shown above, then the City requires and shall be entitled to coverage for the higher coverage limits maintained by Contractor. Any available insurance proceeds in excess of the specified minimum limits of insurance and coverage shall be available to the City.

8. **Claims Made Coverage:** Liability insurance coverage may not be written on a “claims made” or modified occurrence basis. The Certificate of Insurance must clearly provide that the coverage is on an “occurrence” basis.

5-1.24 **OTHER INSURANCE PROVISIONS.**

A. The requirements of the Standard Specifications as to types and limits of insurance coverage to be maintained by the Contractor, and any approval of insurance by the City, are not intended to, and shall not in any manner limit or qualify the liabilities and obligations otherwise assumed by the Contractor pursuant to the Contract, including, but not limited to, the provisions concerning indemnification, nor preclude the City from taking any other action available to it under any other provision of the Contract or law.

B. The City acknowledges that some insurance requirements contained in these Standard Specifications may be fulfilled by self-insurance on the part of the Contractor. However, this shall not in any way limit liabilities assumed by Contractor under the Contract. Any self-insurance must be approved in writing by the City, in its sole discretion and shall not reduce the limits of liability. Any deductibles or self-insured retentions (“SIR”) must be declared on the certificate of insurance and approved by City in writing. Policies containing any

SIR provision shall provide or be endorsed to provide that the SIR may be satisfied by either the named insured or City. City reserves the right to obtain a full certified copy of any insurance policy and endorsements. The failure to exercise this right shall not constitute a waiver of such right.

C. The Contractor agrees to include in its contracts with all subcontractors the same requirements and provisions of this Contract, including the indemnity and insurance requirements, to the extent they apply to the scope of the subcontractor's work. Furthermore, the Contractor shall require its subcontractors to agree to be bound to the Contractor and the City in the same manner and to the same extent as the Contractor is bound to the City under this Contract. Additionally, the Contractor shall obligate its subcontractors to comply with these same provisions with respect to any tertiary subcontractor, regardless of tier. A copy of the City's indemnity and insurance provisions will be furnished to the subcontractor or tertiary subcontractor upon request. Alternatively, the Contractor may insure subcontractor(s) under its own policy.

D. The City, its officers, agents, employees, and volunteers are to be covered as insureds with respect to liability arising out of automobiles owned, leased, hired or borrowed by or on behalf of the Contractor; and with respect to liability arising out of work or operations performed by or on behalf of the Contractor including materials, parts or equipment furnished in connection with such work or operations. Coverage shall not extend to any indemnity coverage for the active negligence of the additional insured in any case where an agreement to indemnify the additional insured would be invalid under California Insurance Code Section 11580.04.

E. The limits of insurance required in this Contract may be satisfied by a combination of primary and excess insurance. Any excess insurance shall contain or be

endorsed to contain a provision that such coverage shall also apply on a primary and noncontributory basis for the benefit of the City (if agreed to in a written contract) before the City's own insurance shall be called upon to protect it as a named insured.

F. The insurance procured by Contractor shall be subject to the approval of the City, but any acceptance of insurance certificates by the City shall in no way limit or relieve Contractor of its duties and responsibilities under the Agreement.

G. Contractor shall be responsible for all premiums, deductibles, and self-insured retention applicable to the insurance it is required to procure under the Contract. All deductibles or self-insured retentions over five hundred thousand dollars (\$500,000) must be approved by the City, in writing. Contractor shall be responsible for all deductibles, self-insured retention payments, and/or increased premiums incurred if the City's policies of insurance are forced to cover damages or respond to claims for which Contractor or its Subcontractors were obligated to provide insurance under the Contract.

H. Failure of the City to enforce in a timely manner any of the requirements of these insurance provisions shall not act as a waiver to enforcement of any of these provisions at a later date.

I. Contractor's indemnity obligations shall not be limited by these insurance provisions and shall survive the expiration of the Contract and the insurance provisions of the Contract shall likewise not be limited by the indemnity provisions of the Contract.

J. THE CITY RESERVES THE RIGHT TO WITHHOLD ANY PROGRESS PAYMENTS TO THE CONTRACTOR IN THE EVENT OF NONCOMPLIANCE WITH ANY INSURANCE REQUIREMENTS.

Bond No. _____
Premium \$ _____

**PUBLIC WORKS
FAITHFUL PERFORMANCE BOND**

(Project: _____)

WHEREAS, the City of Roseville ("CITY") has awarded a bid and contract to _____ as contractor ("PRINCIPAL") for the public work described as _____ (the "WORK"). The contract ("AGREEMENT"), for the public work described above, and all of its terms and conditions are incorporated by reference and made a part hereof; and

WHEREAS, the PRINCIPAL is required to furnish a bond in connection with the AGREEMENT guaranteeing its faithful performance; and

NOW, THEREFORE, we the undersigned PRINCIPAL and _____, a _____, admitted and duly authorized to transact business under the laws of the State of California, as SURETY ("SURETY"), are held and firmly bound unto the CITY or its successors and assigns in the sum of _____ dollars (\$ _____) (which amount is not less than 100% of the AGREEMENT price) to be paid to the CITY or its successors and assigns; and for which payment, well and truly to be made, we bind ourselves, our heirs, executors and administrators, successors or assigns jointly and severally, firmly by these presents.

The condition of this obligation is such that if the PRINCIPAL, or its heirs, executors, administrators, successors or assigns, shall abide by, and in all respects promptly and faithfully perform the covenants, conditions and provisions in said AGREEMENT and any alteration thereof made as therein provided, notice of which alterations to Surety being hereby waived, on its part to be kept and performed at the time and in the manner therein specified, and in all respects according to their true intent and meaning, and shall indemnify and save harmless CITY, its officers, agents, employees, volunteers as therein stipulated, then this obligation shall be null and void; otherwise, this obligation shall be and remain in full force and effect.

As condition precedent to the satisfactory completion of the contract, the obligation of the PRINCIPAL and SURETY under this Bond shall remain in effect for a period of one (1) year after the completion and acceptance of the WORK. During that time, if the PRINCIPAL, its heirs, executors, administrators, successors or assigns fails to make full, complete and satisfactory repair and replacement or totally protect the CITY from any loss or damage made evident during that year which results from or is caused by either defective materials or faulty workmanship in the prosecution of the WORK, then the obligation shall remain in full force and effect. However, anything in

this paragraph to the contrary notwithstanding, the obligation of the SURETY shall continue so long as any obligation of the PRINCIPAL remains.

No prepayment or delay in payments, and no change, extension, addition or alteration of any provision of the AGREEMENT or in the specifications agreed to between the PRINCIPAL and the CITY, or any forbearance on the part of the CITY shall operate to relieve the SURETY. The SURETY hereby waives the provisions of Section 2819 of the California Civil Code. The SURETY waives all rights of subrogation against the CITY or any person employed by the CITY. If the contract price increases by the issuance of change orders, the amount specified in this bond shall increase by the same amount.

Whenever PRINCIPAL shall be and declared by CITY to be in default under the AGREEMENT, SURETY shall promptly remedy the default, or shall promptly do one of the follow at CITY's election:

1. Undertake through its agents or independent contractors, reasonably acceptable to CITY, to complete the AGREEMENT in accordance with its terms and conditions and to pay and perform all obligations of PRINCIPAL under the AGREEMENT, including without limitation, all obligations with respect to warranties, guarantees, and the payment of liquidated damages.
2. Reimburse CITY for all costs CITY incurs in completing the AGREEMENT, and in correcting, repairing or replacing defects in materials or workmanship and/or materials and workmanship which do not conform to the specifications in the AGREEMENT.

SURETY's obligations hereunder are independent of the obligations of any other surety for the performance of the AGREEMENT, and suit may be brought against SURETY and such other sureties, jointly and severally, or against any one or more of them, or against less than all of them without impairing CITY's rights against the others.

No right of action shall accrue on this bond to or for the use of any person or corporation other than CITY or its successors or assigns.

As part of the obligation secured hereby and in addition to the face amount specified therefore, there shall be included costs and reasonable expenses and fees, including reasonable attorneys' fees, incurred by CITY in successfully enforcing such obligation, all to be taxed as costs and included in any judgment rendered.

[SIGNATURES NEXT PAGE]

IN WITNESS WHEREOF, this instrument has been duly executed by the PRINCIPAL and SURETY above-named, on the ____ day of _____, 20__.

PRINCIPAL:

SURETY:

BY: _____

BY: _____

PRINT NAME: _____

PRINT NAME: _____

PRINT TITLE: _____

PRINT TITLE: _____

AND

MAILING ADDRESS:

BY: _____

PRINT NAME: _____

PRINT TITLE: _____

(Notarization by Surety and copy of Power of Attorney required.)

APPROVED AS TO FORM:

BY: _____
City Attorney

Bond No. _____
Premium \$ _____

**PUBLIC WORKS
LABOR AND MATERIALS PAYMENT BOND**

(Project: _____)

WHEREAS, the City of Roseville ("CITY"), has awarded a bid and contract to _____ as contractor ("PRINCIPAL"), for the public work described as _____ (the "WORK"). The contract ("AGREEMENT"), for the public work described above, and all of its terms and conditions are incorporated by reference and made a part hereof; and

WHEREAS, the PRINCIPAL is required to furnish a bond in connection with the AGREEMENT guaranteeing payment of persons who provide labor and material; and

NOW, THEREFORE, we the undersigned PRINCIPAL and _____, a _____, admitted and duly authorized to transact business under the laws of the State of California, as SURETY ("SURETY"), are held and firmly bound unto the CITY or its successors and assigns in the sum of _____ dollars (\$ _____) (which amount is not less than 100% of the AGREEMENT price) to be paid to the CITY or its successors and assigns; and for which payment, well and truly to be made, we bind ourselves, our heirs, executors and administrators, successors or assigns jointly and severally, firmly by these presents.

The condition of the obligation is such that if the PRINCIPAL, its subcontractors, heirs, executors, administrators, successors or assigns fails to pay any of the persons named in Section 8004 or 9100 of the Civil Code of the State of California, or the amounts due under the Unemployment Insurance Code of the State of California, or any amounts required to be deducted, withheld and paid over to the Employment Development Department from the wages of employees of the PRINCIPAL and its subcontractors pursuant to Section 13020 of the Unemployment Insurance Code, with respect to work or labor performed by any such claimant, that the SURETY will pay for the same, in an amount not exceeding the sum specified in this bond, and also, in case suit is brought upon the bond, shall pay reasonable attorneys' fees, to be fixed by the Court.

This bond shall inure to the benefit of any and all persons, companies, and corporations entitled to file a Stop Payment Notice pursuant to the provisions of Section 9350 et seq. of the Civil Code of the State of California, so as to give a right of action to them or their assigns in any suit brought upon this bond.

No prepayment or delay in payments, and no change, extension, addition or alteration of any provision of the AGREEMENT or in the specifications agreed to between the PRINCIPAL and the CITY, or any forbearance on the part of the CITY shall operate to relieve the SURETY. The SURETY hereby waives the provisions of Section 2819 of the California Civil Code. The SURETY waives all rights of subrogation against the CITY or any person employed by the CITY. If the contract price increases by the issuance of change orders, the amount specified in this bond shall increase by the same amount.

As part of the obligation secured hereby and in addition to the face amount specified therefore, there shall be included costs and reasonable expenses and fees, including reasonable attorneys' fees, incurred by CITY in successfully enforcing such obligation, all to be taxed as costs and included in any judgment rendered.

IN WITNESS WHEREOF, this instrument has been duly executed by the PRINCIPAL and SURETY above-named, on the _____ day of _____, 20__.

PRINCIPAL:

SURETY:

BY: _____

BY: _____

PRINT NAME: _____

PRINT NAME: _____

PRINT TITLE: _____

PRINT TITLE: _____

AND

MAILING ADDRESS:

BY: _____

PRINT NAME: _____

PRINT TITLE: _____

(Notarization by Surety and copy of Power of Attorney required.)

APPROVED AS TO FORM:

BY: _____
City Attorney

CITY OF ROSEVILLE

GENERAL CONDITIONS

FOR

BUILDINGS AND GROUNDS

GC

**CITY OF ROSEVILLE
GENERAL CONDITIONS
FOR
BUILDINGS AND GROUNDS**

SECTION 1: DEFINITIONS AND TERMS.....	GC-1:1
1-1.01 GENERAL	GC-1:1
1-1.02 ACCEPTANCE	GC-1:1
1-1.03 ADDENDUM	GC-1:1
1-1.04 AS-BUILT DOCUMENTS, AS-BUILT DRAWINGS AND RECORD DOCUMENTS.....	GC-1:1
1-1.05 ASSESSMENT	GC-1:1
1-1.06 BENEFICIAL OCCUPANCY	GC-1:2
1-1.07 BID GUARANTY.....	GC-1:2
1-1.08 BIDDER	GC-1:2
1-1.09 BIDDING DOCUMENTS	GC-1:2
1-1.10 CHANGE ORDER.....	GC-1:2
1-1.11 CITY.....	GC-1:2
1-1.12 CITY ATTORNEY	GC-1:2
1-1.13 CITY CLERK.....	GC-1:2
1-1.14 CLAIM.....	GC-1:2
1-1.15 CONSTRUCTION SCHEDULE	GC-1:3
1-1.16 CONTRACT OR AGREEMENT	GC-1:3
1-1.17 CONTRACT CONDITIONS	GC-1:3
1-1.18 CONTRACT DOCUMENTS	GC-1:3
1-1.19 CONTRACT DRAWINGS.....	GC-1:3
1-1.20 CONTRACT PRICE.....	GC-1:4
1-1.21 CONTRACT TIME	GC-1:4
1-1.22 CONTRACTOR.....	GC-1:4
1-1.23 DAY OR DAYS.....	GC-1:4
1-1.24 DEPARTMENT	GC-1:4
1-1.25 DIRECT COSTS	GC-1:4
1-1.26 DIRECTOR.	GC-1:6
1-1.27 EMERGENCY.	GC-1:6
1-1.28 ENGINEER OR ARCHITECT.....	GC-1:7
1-1.29 FINAL COMPLETION.....	GC-1:7
1-1.30 FORCE ACCOUNT.....	GC-1:7
1-1.31 GENERAL NOTES.....	GC-1:7
1-1.32 INSTALLATION, INSTALL.....	GC-1:7
1-1.33 LABORATORY	GC-1:7
1-1.34 LEGAL HOLIDAYS.....	GC-1:7
1-1.35 LIQUIDATED DAMAGES.....	GC-1:7
1-1.36 NOTICE OF COMPLETION	GC-1:8
1-1.37 NOTICE TO PROCEED	GC-1:8
1-1.38 NOTICE OF TERMINATION	GC-1:8

1-1.39	OVERHEAD.....	GC-1:8
1-1.40	PREMISES	GC-1:9
1-1.41	PROFESSIONAL ENGINEER	GC-1:9
1-1.42	PROJECT MANUAL	GC-1:9
1-1.43	PROPOSAL FORMS.....	GC-1:9
1-1.44	REQUEST FOR INFORMATION (RFI).	GC-1:9
1-1.45	SAFETY	GC-1:9
1-1.46	SCHEDULE OF VALUES.	GC-1:9
1-1.47	SHOP DRAWINGS.....	GC-1:10
1-1.48	SPECIFICATIONS.....	GC-1:10
1-1.49	SUBCONTRACTOR.....	GC-1:10
1-1.50	SUBMITTALS	GC-1:10
1-1.51	SUPPLEMENTAL CONDITIONS	GC-1:10
1-1.52	SUPPLIER.....	GC-1:10
1-1.53	WORK.....	GC-1:11
1-1.54	WORK SITE.....	GC-1:11
1-1.55	WORKING DRAWINGS.....	GC-1:11
SECTION 2: CONTROL AND SCOPE OF THE WORK.....		GC-2:1
2-1.01	AUTHORITY OF DIRECTOR	GC-2:1
2-1.02	INTENT OF CONTRACT DOCUMENTS.....	GC-2:1
2-1.03	EXAMINATION AND VERIFICATION OF CONTRACT DOCUMENTS.....	GC-2:2
2-1.04	CONTRACT DRAWINGS.....	GC-2:3
2-1.05	COORDINATION AND INTERPRETATION OF CONTRACT DOCUMENTS.....	GC-2:3
2-1.06	INDEPENDENT CONTRACTOR STATUS.....	GC-2:5
2-1.07	ORDER OF WORK	GC-2:5
2-1.08	SUBMITTALS	GC-2:5
2-1.08A	SHOP DRAWINGS.....	GC-2:6
2-1.08B	DESCRIPTIVE DATA	GC-2:7
2-1.08C	SAMPLES	GC-2:7
2-1.08D	MANUALS, INSTRUCTIONS AND AFFIDAVIT.....	GC-2:7
2-1.08E	ALTERNATIVES.....	GC-2:10
2-1.09	DISPOSAL OF MATERIAL OUTSIDE THE WORK SITE.....	GC-2:12
2-1.10	ACCESS TO THE WORK	GC-2:12
2-1.11	TEMPORARY UTILITIES	GC-2:12
2-1.12	UTILITY FACILITIES	GC-2:13
2-1.13	PRESERVATION AND CLEANING	GC-2:14
2-1.14	LIMITATIONS ON WORK SITE AND PREMISES.....	GC-2:14
2-1.15	DUST CONTROL	GC-2:15
2-1.16	SANITATION	GC-2:15
2-1.17	NIGHT WORK AND NORMAL WORKING HOURS.....	GC-2:15
2-1.18	LINES AND GRADES.....	GC-2:16
2-1.19	ARCHEOLOGICAL DISCOVERIES.....	GC-2:17
2-1.20	PRESERVATION OF MONUMENTS.....	GC-2:17
2-1.21	CONFORMITY WITH CONTRACT DOCUMENTS.....	GC-2:18

2-1.22	FINAL CLEANUP	GC-2:18
2-1.23	AS-BUILT DOCUMENTS AND DRAWINGS	GC-2:18
2-1.24	SUPERINTENDENCE	GC-2:19
2-1.25	CHARACTER OF WORKER	GC-2:20
2-1.26	INSPECTION.....	GC-2:20
2-1.27	REMOVAL OF REJECTED AND UNAUTHORIZED WORK	GC-2:21
SECTION 3: CHANGES IN THE WORK		GC-3:1
3-1.01	CHANGES	GC-3:1
3-1.02	PROPOSED CHANGE ORDERS	GC-3:2
3-1.03	EMERGENCY AND INDETERMINATE TYPE CHANGE ORDERS ..	GC-3:3
3-1.04	EXECUTED CHANGE ORDER.....	GC-3:3
3-1.05	CONTRACT PRICE ADJUSTMENT	GC-3:3
3-1.06	FORCE ACCOUNT PAYMENT	GC-3:5
3-1.06A	LABOR	GC-3:6
3-1.06B	MATERIALS.....	GC-3:6
3-1.06C	EQUIPMENT.....	GC-3:7
3-1.06D	MARKUPS	GC-3:8
3-1.06E	RECORDS.....	GC-3:9
3-1.07	COST REDUCTION PROPOSALS.....	GC-3:11
SECTION 4: CONTROL OF MATERIALS		GC-4:1
4-1.01	MATERIALS	GC-4:1
4-1.02	PRODUCT AND REFERENCE STANDARDS.....	GC-4:2
4-1.03	SAMPLING AND TESTING OF MATERIALS.....	GC-4:2
4-1.04	CERTIFICATES OF COMPLIANCE.....	GC-4:7
SECTION 5: LEGAL RELATIONS AND RESPONSIBILITY		GC-5:1
5-1.01	LAWS TO BE OBSERVED	GC-5:1
5-1.02	HOURS OF LABOR	GC-5:1
5-1.03	NONDISCRIMINATION	GC-5:2
5-1.04	PREVAILING WAGE.....	GC-5:3
5-1.05	REGISTRATION REQUIRED AS QUALIFICATION TO BID	GC-5:6
5-1.06	PAYROLL RECORDS.....	GC-5:7
5-1.07	SAFETY REQUIREMENTS	GC-5:10
5-1.08	SUBSURFACE EXCAVATIONS, NOTIFICATION.....	GC-5:15
5-1.09	PUBLIC SAFETY	GC-5:15
5-1.10	EMERGENCIES.....	GC-5:17
5-1.11	APPRENTICES	GC-5:18
5-1.12	FAIR LABOR STANDARDS ACT	GC-5:18
5-1.13	WORKERS' COMPENSATION.....	GC-5:19
5-1.14	AIR POLLUTION CONTROL AND ASBESTOS.....	GC-5:19
5-1.15	USE OF PESTICIDES	GC-5:20
5-1.16	SOUND AND LIGHT CONTROL REQUIREMENTS.....	GC-5:20
5-1.17	WEIGHT LIMITATIONS	GC-5:21
5-1.18	ENVIRONMENTAL CLEARANCES; MITIGATION MONITORING PROGRAMS; AND REGULATORY AGENCY PERMIT	

	REQUIREMENTS	GC-5:21
5-1.19	PERMITS AND LICENSES	GC-5:21
5-1.20	WATER POLLUTION	GC-5:22
5-1.21	PROTECTION AND USE OF PROPERTY	GC-5:23
5-1.22	RESPONSIBILITY FOR DAMAGE AND INDEMNIFICATION	GC-5:24
5-1.23	INSURANCE COVERAGE	GC-5:26
5-1.24	OTHER INSURANCE PROVISIONS	GC-5:31
5-1.25	THIRD PARTY BENEFICIARY	GC-5:33
5-1.26	COORDINATION AND ACCESS	GC-5:33
5-1.27	OCCUPANCY BY THE DEPARTMENT PRIOR TO ACCEPTANCE ..	GC-5:34
5-1.28	RIGHT TO OPERATE UNSATISFACTORY FACILITIES AND EQUIPMENT	GC-5:35
5-1.29	CONTRACTOR'S RESPONSIBILITY FOR THE WORK	GC-5:36
5-1.30	RESPONSIBILITY FOR UTILITIES	GC-5:37
5-1.31	PROPERTY RIGHTS IN MATERIALS	GC-5:39
5-1.32	COURT ORDERED DELAY	GC-5:39
5-1.33	NO PERSONAL LIABILITY	GC-5:39
5-1.34	RIGHTS IN LAND AND IMPROVEMENTS	GC-5:40
5-1.35	ANTITRUST CLAIMS	GC-5:40
5-1.36	RIGHTS TO DRAWINGS, TECHNICAL DATA PATENTS	GC-5:40
5-1.37	PAYMENT OF TAXES	GC-5:41
5-1.38	GRATUITIES AND CONFLICT OF INTEREST	GC-5:42
5-1.39	COOPERATION	GC-5:43
5-1.40	DIGGING TRENCHES OR OTHER EXCAVATIONS	GC-5:43
5-1.41	CONTRACTOR REGISTRATION	GC-5:44
5-1.42	CITY OF ROSEVILLE ENCROACHMENT PERMITS AND RIGHTS-OF-WAY	GC-5:45
SECTION 6: PROSECUTION AND PROGRESS		GC-6:1
6-1.01	SUBLETTING AND SUBCONTRACTING	GC-6:1
6-1.02	ASSIGNMENT	GC-6:2
6-1.03	BEGINNING OF WORK	GC-6:2
6-1.04	PROGRESS SCHEDULE	GC-6:3
6-1.05	SCHEDULE OF VALUES	GC-6:9
6-1.06	CITY'S RIGHT TO STOP WORK	GC-6:9
6-1.07	TIME OF COMPLETION	GC-6:11
6-1.08	LIQUIDATED DAMAGES	GC-6:12
6-1.09	DELAYS AND EXTENSIONS TO THE WORK	GC-6:13
6-1.10	TERMINATION	GC-6:18
6-1.10A	<i>TERMINATION OF AGREEMENT – CONVENIENCE OF CITY</i> ..	GC-6:18
6-1.10B	<i>TERMINATION OF AGREEMENT - FOR CAUSE</i>	GC-6:21
SECTION 7: ACCEPTANCE AND PAYMENT		GC-7:1
7-1.01	ACCEPTANCE	GC-7:1
7-1.02	SCOPE OF PAYMENT	GC-7:2
7-1.03	NOTICE OF POTENTIAL CLAIM	GC-7:2
7-1.04	CLAIMS	GC-7:5

7-1.05 DISPUTE RESOLUTION PROCEDURE.....GC-7:6
7-1.06 STOP PAYMENT NOTICESGC-7:7
7-1.07 PROGRESS PAYMENTSGC-7:7
7-1.08 PAYMENT FOR MATERIALS AND EQUIPMENT ON HAND.....GC-7:9
7-1.09 RETENTION ON PROGRESS PAYMENTSGC-7:11
7-1.10 FINAL PAYMENTGC-7:12
7-1.11 CLERICAL ERRORSGC-7:14
7-1.12 WARRANTYGC-7:14
7-1.13 WARRANTY OF TITLEGC-7:16

SECTION 1

DEFINITIONS AND TERMS

1-1.01 **GENERAL.** When the following abbreviations and terms or pronouns in place of them appear in the Contract Documents, the intent and meaning shall be interpreted as provided in this Section 1.

1-1.02 **ACCEPTANCE.** Formal Acceptance by resolution by the Roseville City Council of the Contract when completed in all respects in accordance with the Contract Documents and any modifications previously approved.

1-1.03 **ADDENDUM.** Written interpretation or revision to any of the Contract Documents issued by the City before the bid opening.

1-1.04 **AS-BUILT DOCUMENTS, AS-BUILT DRAWINGS AND RECORD DOCUMENTS.** As-Built Documents, As-Built Drawings and Record Documents are all contract documents modified to reflect changes during the construction phase. Specifically, As-Built Documents/Drawings are a revised set of drawings submitted by the Contractor upon Final Completion of a project. They reflect changes made in the Specifications and Working Drawings during the construction process, and show the exact dimensions, geometry, and location of all elements of the work completed under the Contract. Record Documents, on the other hand, are compiled by the Engineer or Architect based on the As-Built Documents/Drawings submitted by the Contractor. They reflect the Engineer or Architect's concurring review of what changes were denoted, why they were made and where they occurred and create a record set of drawings.

1-1.05 **ASSESSMENT.** A cost imposed on the Contractor for non-compliance

with certain contractual requirements.

1-1.06 **BENEFICIAL OCCUPANCY.** The taking possession of a portion of the Work by the City for its use and/or occupancy on other than a temporary or emergency basis.

1-1.07 **BID GUARANTY.** The cashier's, certified check, irrevocable standby letter of credit, deposit of securities, or Bidder's Bond, accompanying the bid submitted by the Bidder, as a guaranty that the Bidder will enter into an agreement with the City for the performance of the Work, if the Agreement is awarded to Bidder, and the Bidder will submit the required Contract Bonds and Certificate of Insurance. Also referred to as the Bidder's Security.

1-1.08 **BIDDER.** Individual, firm, partnership, limited liability company, corporation, joint venture, or any combination thereof, submitting a Proposal for the Work, acting directly, or through a duly authorized representative.

1-1.09 **BIDDING DOCUMENTS.** Includes the Notice to Bidders, Bidding Requirements, Contract Conditions, Drawings, and Addenda.

1-1.10 **CHANGE ORDER.** Any written order to the Contractor directing an addition, deletion, or modification of the Work, or an adjustment in the Contract Price or Contract Time provided in the Contract Documents and issued after the Agreement has been signed.

1-1.11 **CITY.** The City of Roseville.

1-1.12 **CITY ATTORNEY.** The City Attorney of the City.

1-1.13 **CITY CLERK.** The City Clerk of the City.

1-1.14 **CLAIM.** A separate demand by Contractor sent by registered mail or certified mail with return receipt requested, for one or more of the following: (a) a time extension, including, without limitation, for relief for damages or penalties for delay assessed by

the City; (b) payment by the City of money or damages arising from work done by, or on behalf of, Contractor pursuant to the Contract Documents and payment for which is not otherwise expressly provided or to which Contractor is not otherwise entitled; and (c) payment of an amount that is disputed by the City.

1-1.15 **CONSTRUCTION SCHEDULE.** A list or graphic display of construction activities required for completing the Work, in a format required by the Contract Documents. The duration, start and finish date, and sequence of significant activities, critical path, float and milestones must be indicated in the Construction Schedule.

1-1.16 **CONTRACT OR AGREEMENT.** The written agreement relating to the Work to be performed, the labor, materials, and equipment to be furnished, and the payment to be made therefor. The Agreement/Contract is part of and incorporates all of the Contract Documents.

1-1.17 **CONTRACT CONDITIONS.** Includes the General Conditions, Supplemental Conditions, and Specifications.

1-1.18 **CONTRACT DOCUMENTS.** Includes those documents that form the basis of the Contract, including but not limited to, Bidding Documents, the Bid or Proposal, Contract Bonds, the Contract, all required insurance certificates or endorsements, all bonds, all required certifications or statements, Change Orders, any Contract Amendment, any City Standard which is incorporated by reference and these City of Roseville General Conditions for Buildings and Grounds.

1-1.19 **CONTRACT DRAWINGS.** The official drawings including plans, elevations, sections, detail drawings, diagrams, plated, General Notes, information and schedules thereon, or exact reproductions thereof, showing the location, character, dimension, and details

of the Work. The Contract Drawings include any drawings or plates bound within the Supplemental Conditions.

1-1.20 **CONTRACT PRICE.** The total compensation to be paid to the Contractor in accordance with the terms of the Agreement.

1-1.21 **CONTRACT TIME.** The number of Days, or portion thereof, allowed for completion of the Work, including all authorized time extensions. The effective date for commencement of the Work specified in the Notice to Proceed shall define the beginning of the Contract Time.

1-1.22 **CONTRACTOR.** Individual, firm, partnership, limited liability company, corporation, joint venture, or any combination thereof, who has entered into the Agreement with City.

1-1.23 **DAY OR DAYS.** Unless otherwise designated, Day or Days as used in the Contract Documents will be understood to mean calendar Day or Days.

1-1.24 **DEPARTMENT.** The Department for Contract Administration, as identified in the Supplemental Conditions.

1-1.25 **DIRECT COSTS.** Those cost items (including labor, materials, equipment and any subcontractor's work) that are used in the actual performance of, and are specifically and uniquely attributable to the Work or changed Work. Direct Costs do not include Overhead. Direct Costs only include the following:

A. Payroll costs for employees in the direct employ of Contractor in the performance of the Work under schedules of job classifications agreed upon by City and Contractor. Payroll costs for employees not employed full time on the Work shall be apportioned on the basis of their time spent on the Work. Payroll costs shall include salaries and

wages plus the cost of fringe benefits which shall include social security contributions, unemployment, excise and payroll taxes, workers' compensation, health and retirement benefits, sick leave, vacation and holiday pay applicable thereto. Such employees may include superintendents and foremen at the site. The expenses of performing work after regular working hours, on Saturday, Sunday or legal holidays shall be included in the above only to the extent authorized by City in writing.

B. Cost of all materials and equipment furnished and incorporated in the Work, including costs of transportation and storage thereof, and suppliers' field services required in connection therewith. All trade discounts, rebates and refunds and all returns from sale of surplus materials and equipment shall accrue to City, and Contractor shall make provisions so that they may be obtained.

C. Payments made by Contractor to the subcontractors for work performed by subcontractors. If required by City, Contractor shall obtain competitive bids from subcontractors acceptable to Contractor and shall deliver such bids to City who will then determine which bids will be accepted. If a subcontract provides that the subcontractor is to be paid on the basis of cost of the work plus a fee, the subcontractor's cost of the work shall be determined in the same manner as Contractor's cost of the work. All subcontracts shall be subject to the other provisions of the Contract Documents insofar as applicable.

D. Costs of special consultants (including engineers, architects, testing laboratories, surveyors, and accountants) employed for services specifically, and only, related to the Work.

E. Supplemental costs including the following:

1. The proportion of necessary transportation, travel and subsistence

expenses of Contractor's employees incurred in discharge of duties connected with the Work.

2. Cost, including transportation and maintenance, of all materials, supplies, equipment, machinery, appliances, office and temporary facilities at the site and hand tools not owned by the workers, which are consumed in the performance of the Work, and cost, less market value of such items used but not consumed which remain the property of Contractor.

3. Rentals of all construction equipment and machinery and the parts thereof whether rented from Contractor or others in accordance with rental agreements approved by City, and the costs of transportation, loading, unloading, installation, dismantling and removal thereof, all in accordance with terms of said rental agreements. The rental of any such equipment, machinery or parts shall cease when the use thereof is no longer necessary for the Work.

4. Sales, consumer, use or similar taxes related to the Work, and for which Contractor is liable, imposed by laws and regulations.

5. The cost of utilities (including the meter and all associated installation costs), fuel and sanitary facilities at the site.

6. Cost of premiums for additional bonds and insurance required because of changes in the Work.

1-1-26 **DIRECTOR.** Director of the Department for Contract Administration or his or her designee.

1-1.27 **EMERGENCY.** Any sudden generally unforeseen occurrence (such as a fire, flood, storm, earthquake, civil disorder, or other natural and/or man-made disaster) that has the potential to adversely affect the safety of life, the Work, and/or adjacent property; to interrupt contracts essential to the performance of the Work; and/or to cause catastrophic failure of City

equipment and/or facilities.

1-1.28 **ENGINEER OR ARCHITECT.** Professional Engineer or Architect designated for a particular project responsible for signing and sealing the permit drawings, interpretation of the drawings where ambiguities exist, review of requests for information, design Change requests and Shop Drawings, resolution of errors and omissions, and finalization of Record Documents.

1-1.29 **FINAL COMPLETION.** When the project has been completed according to the terms and conditions set forth in the Contract Documents. Final Completion is not the same as Acceptance.

1-1.30 **FORCE ACCOUNT.** Payment by force account shall mean payment on the basis of the Contractor's time and materials.

1-1.31 **GENERAL NOTES.** The written instructions, provisions, conditions or other requirements appearing on the Contract Drawings and so identified thereon, which pertain to the performance of the Work.

1-1.32 **INSTALLATION, INSTALL.** Completely assembling, erecting, and/or connecting materials, parts, components, supplies, and related equipment specified or required for the completion of the Work.

1-1.33 **LABORATORY.** Established professional laboratories authorized by the City to test materials and Work involved in the Contract.

1-1.34 **LEGAL HOLIDAYS.** Those days designated as Federal holidays or declared by the City, or otherwise specified in the Contract Documents.

1-1.35 **LIQUIDATED DAMAGES.** The amount prescribed in the Contract Documents to be paid to the City or to be deducted from any payments due or to become due the

Contractor for each day's delay in completing the whole or any specified portion of the Work beyond the time allowed in the Supplemental Conditions.

1-1.36 **NOTICE OF COMPLETION.** A legal notice filed by the City with the Placer County Recorder's Office stating that construction has been completed and accepted by the City.

1-1.37 **NOTICE TO PROCEED.** A written notice given by the City to the Contractor fixing the date on which the Contract Time will commence to run.

1-1.38 **NOTICE OF TERMINATION.** Written notice from the City to the Contractor and/or its Surety terminating the Agreement, or a portion thereof, either for convenience of the City or for default due to the Contractor's failure to perform its contractual obligations.

1-1.39 **OVERHEAD.** Business or administrative expenses (including but not limited to office expenses, administrative staff, rent, insurance, utilities) not chargeable to a particular part of the Work. The term "Overhead" shall include all of the following:

A. Payroll costs and other compensation of Contractor's officers, executives, principals (of partnerships and sole proprietorships), general managers, engineers, architects, estimators, attorneys, auditors, accountants, purchasing and contracting agents, expeditors, timekeepers, clerks, and other personnel employed by Contractor whether at the Work Site or in Contractor's principal or a branch office for general administration of the Work and not specifically included in the agreed upon schedule of job classifications, all of which are to be considered administrative costs covered by the Contractor's fee.

B. Expenses of Contractor's principal and branch offices other than Contractor's office at the site.

C. Any part of Contractor's capital expenses, including interest on Contractor's capital employed for the Work and charges against Contractor for delinquent payments.

D. Cost of premiums for all bonds and for all insurance whether or not Contractor is required by the Contract Documents to purchase and maintain the same, except as provided in section 1-1.25.

E. Other overhead or general expense costs of any kind.

1-1.40 **PREMISES.** Shall mean the area within construction easements, easements, rights of entry and City owned property which surrounds the Work Site, limited by the property lines thereof. In some cases Premises may coincide with the Work Site.

1-1.41 **PROFESSIONAL ENGINEER.** An engineer licensed by the Board of Registration for Professional Engineers, State of California.

1-1.42 **PROJECT MANUAL.** A book containing all Contract Documents.

1-1.43 **PROPOSAL FORMS.** The approved forms upon which the City requires that each Bidder submit its bid with regard to the Agreement.

1-1.44 **REQUEST FOR INFORMATION (RFI).** A document issued by the Contractor requesting information concerning the Contract Documents.

1-1.45 **SAFETY.** Includes the practice of identifying potential hazards, assessing their risk, taking corrective action where possible, including and providing control measures such as engineering design, written procedures, and the personal protective equipment for workers in order to eliminate or reduce the risk for exposure in the workplace.

1-1.46 **SCHEDULE OF VALUES.** The breakdown of the Contract Price that will serve as the basis for Contractor's Applications of Payment. Any lump sum bid item

included within the Contract Price will be apportioned among values relating to specific components of the Work covered by said lump sum.

1-1.47 **SHOP DRAWINGS.** Drawings, plans, diagrams, schedules, and other data specifically prepared and submitted to the City by the Contractor, showing in detail: (a) the proposed fabrication and assembly of a special component of the Work; and (b) the Installation (form, fit and attachment details) of a special component of the Work. Shop Drawings shall be deemed to include Working Drawings, Product Data, literature, and applicable performance and test data.

1-1.48 **SPECIFICATIONS.** The technical Specifications for the Work prepared by the Director or an Engineer or Architect describing in detail the nature of the Work, its components, any performance standards, and how the Work is to be constructed.

1-1.49 **SUBCONTRACTOR.** Any individual, firm, partnership, limited liability company, corporation, joint venture, or combination thereof, other than employees of the Contractor, engaged by the Contractor to furnish services, labor, equipment and materials for a portion of the Work.

1-1.50 **SUBMITTALS.** Those documents required to be submitted by the Contractor for review by the City in accordance with the Contract Documents.

1-1.51 **SUPPLEMENTAL CONDITIONS.** The Supplemental Conditions are specific clauses modifying or supplementing these General Conditions.

1-1.52 **SUPPLIER.** Any individual, firm, partnership, limited liability company, corporation, joint venture, or combination thereof, other than employees of the Contractor, that supplies a tangible product as a portion of the Work, with services usually limited to delivery and/or required testing, and with manufacturing, fabrication, or production facilities located off

the Work Site.

1-1.53 **WORK.** The furnishing of all labor, and the furnishing and Installing of all materials, articles, supplies and equipment as specified, designated, or required by the Contract Documents.

1-1.54 **WORK SITE.** All or portion of the Premises that the Work is limited to as shown on the Contract Drawings or designated by the Director. Public streets are not included unless Work is being done within the street right-of-way.

1-1.55 **WORKING DRAWINGS.** Original drawings prepared by the Contractor and/or its Subcontractors or Suppliers, of any tier, illustrating Work required for construction that will not become an integral part of the completed Work. This includes, but is not limited to, drawings for temporary structures such as decking, bulkheads, excavation supports, utility support, groundwater control, forming, falsework, access roads, staging areas, staging plans, and diversion plans. A Working Drawing is one type of a Shop Drawing.

SECTION 2

CONTROL AND SCOPE OF THE WORK

2-1.01 **AUTHORITY OF DIRECTOR.** The Contract shall be performed in a manner satisfactory to the Director who shall decide all questions which may arise as to the quality or acceptability of materials furnished and Work performed and as to the manner of performance and rate of progress of the Work; all questions which may arise as to the interpretation of the Contract Documents; all questions as to the acceptable fulfillment of the Contract on the part of the Contractor; and all questions as to compensation. The Director shall have authority to enforce and make effective such decisions and orders in the event the Contractor fails to promptly carry out the same.

2-1.02 **INTENT OF CONTRACT DOCUMENTS.** The Contract Documents are complementary, and what is called for by one shall be as binding as if called for by all. The intent of the Contract Documents is to describe the details for the construction and completion of the Work. Where the Contract Documents describe portions of the Work in general terms, but not in complete detail, it is understood that only the best general practice shall be followed and that only materials and workmanship of the best quality are to be used. Any Work, materials, or equipment that are customarily provided, or that are reasonably inferable from the Contract Documents as being required to produce the intended result, shall be supplied, whether or not specifically called for. When words, which have a well-known technical or trade meaning are used to describe work, materials, or equipment, such words shall be interpreted in accordance with that meaning. Unless otherwise specified, the Contractor shall furnish all labor, materials, tools, equipment, and incidentals, and do all the Work involved in executing the Contract in a

satisfactory and workmanlike manner.

Reference to standard specifications, manuals or codes of any technical society, organization or association, or to the laws or regulations of any governmental authority, whether such reference be specific or by implication, shall mean the latest standard specification, manual, code, laws, or regulations in effect on the first published date of the Notice to Contractors, except as may be otherwise specifically stated. However, no provision of any referenced standard specification, manual or code (whether or not specifically incorporated by reference in the Contract Documents) shall be effective to change the duties and responsibilities of City or Contractor, or any of their consultants, agents, or employees from those set forth in the Contract Documents, nor shall it be effective to assign to City, or City's designated representative, any duty or authority to supervise or direct the furnishing or performance of the Work or any duty or authority to undertake responsibility contrary to other provisions of the Contract Documents.

The Contract Documents are divided into parts, divisions, sections and articles for convenience, organization and reference. Generally, there has been no attempt to divide the Specifications sections into work performed by the various building trades, work by separate Subcontractors, or work required for separate facilities in the project.

2-1.03 **EXAMINATION AND VERIFICATION OF CONTRACT**

DOCUMENTS. The Contractor shall thoroughly examine and become familiar with all of the various parts of the Contract Documents and shall determine the nature and location of the Work, the general and local conditions (including applicable laws) and all other matters which can in any way affect the cost, progress or performance of the Work under this Agreement. Failure to make an examination necessary for this determination shall not release the Contractor from the obligations of the Agreement. No oral agreement or conversation with any officer, or employee

of the City, or with the City's designated representative either before or after the execution of the Agreement, shall affect or modify any of the terms or obligations contained in the Contract Documents.

2-1.04 **CONTRACT DRAWINGS.** The Contract Drawings consist of general drawings and show such plans, elevations, sections, details and schedules as are necessary to give a graphic and pictorial description of the contemplated construction. All authorized alterations affecting the requirements and information given on the Contract Drawings shall be in writing.

2-1.05 **COORDINATION AND INTERPRETATION OF CONTRACT DOCUMENTS.** All Contract Documents are essential parts of the Contract, and a requirement occurring in one is as binding as though occurring in all. They are intended to be complementary, and to describe and provide for a complete Work.

In the event of inconsistencies between requirements contained in different components of the Contract Documents, the precedence of the Contract Documents shall be as follows to resolve conflicts:

1. Change Orders
2. The Contract (including Addenda)
3. The Supplemental Conditions
4. Specifications
5. Contract Drawings
6. The General Conditions

Should it appear that the Work to be done or any of the matters relative thereto are not sufficiently detailed or explained in the Contract Documents, the Contractor shall submit a

Request for Information (“RFI”) to the Director for such further explanations as may be necessary and shall conform to the written explanation given as if part of the Contract Documents. The decisions of the Director shall be final.

Contractor shall anticipate that it will be necessary to prepare and submit RFIs regarding the Contract Documents. The City will respond to each RFI by no later than fourteen (14) Days after receipt of the RFI, unless the RFI is of significant complexity. Furthermore, in the event that there are numerous RFIs pending, Contractor shall cooperate with the City in establishing a priority for responding to the RFIs, and potentially some RFIs may be responded to beyond the fourteen (14) Day period.

Each RFI prepared by Contractor shall be full and complete. Contractor shall prepare RFIs so as to not cause any delay to the progress of the Work and to not cause any impact to Contractor’s labor productivity in the field. Contractor shall not assert any Claims for delay or interference against the City if Contractor fails to timely submit any RFI to the City, after consideration of the response period allowed for by the City.

The response to an RFI shall not, by itself, constitute a writing that authorizes Contractor to perform any Work that causes an adjustment to either the Contract Price or the Contract Time. If Contractor believes that any response to any RFI should constitute a compensable change, Contractor shall provide a Notice of Potential Claim as provided in Section 7-1.03, below. Contractor’s failure to provide the required written notice shall constitute a waiver of the Contractor’s right to seek a compensable change based on the RFI response.

The Contractor shall examine all Contract Documents; shall verify all figures in the Contract Documents before laying out the Work; shall promptly notify the City of all errors, inconsistencies, and/or omissions that it discovers; and, in instances where such non-

conformities are discovered, shall obtain specific instructions in writing from the City before proceeding with the Work. Contractor's performance of any Work affected by such non-conformities prior to the City's decision shall be at the Contractor's risk. Any Work that is customarily provided or that is reasonably inferable shall not relieve the Contractor from performing such work at no additional expense and/or delay, and such Work shall be performed as if fully set forth in the Contract Documents.

2-1.06 **INDEPENDENT CONTRACTOR STATUS.** The Contractor shall independently perform all Work required by the Contract Documents and shall not be considered as an agent or employee of the City, nor shall the Contractor's Subcontractors or employees be considered as subagents of the City.

The Contractor and Contractor's Subcontractors shall be licensed in accordance with the laws of the State of California and as more particularly described in the bidding documents or elsewhere in the Contract Documents.

2-1.07 **ORDER OF WORK.** When required by the Contract Documents, the Contractor shall follow the sequence of operations set forth therein. Full compensation for conforming to such requirements will be considered as included in the prices paid for the various Contract items of work, and no additional compensation will be allowed therefor.

2-1.08 **SUBMITTALS.** It shall be the Contractor's responsibility to timely submit, so as to cause no delay in the Work, all Shop Drawings, descriptive data, manuals, instructions, affidavits, samples for the various trades as required by the Supplemental Conditions and Specifications, and offers of alternatives, if any. Such Submittals shall be checked and coordinated by the Contractor with the Work of other trades involved before they are submitted to the Director for examination.

The Contractor shall deliver at least one (1) electronic copy of the Submittals to the Director, and one (1) hard copy if requested. Work requiring the submittal of working drawings, descriptive data or samples shall not begin prior to approval of said Submittal by the Director.

The time allowed for review of each Submittal will be as indicated in the Supplemental Conditions. Review time will start upon receipt of the Submittal by the Director and will end upon the Director's mailing of the Submittals to the Contractor. Defective, incomplete or partial Submittals will be returned to the Contractor unreviewed.

Submittals shall be made by a letter of transmittal that shall contain a list of all matter submitted and identification of all variations from the Contract Documents contained in the Submittal. The letter and all items accompanying the same shall be fully identified as to project name and location, Contractor's name, district, county, and Contract number, with ample cross-references to the Contract Documents, to facilitate identification of items and their location in the Work.

All Shop Drawings and supporting data, catalogs, schedules, shall be submitted as the instruments of the Contractor, who shall be responsible for their accuracy and completeness. These Submittals may be prepared by the Contractor, Subcontractors, or Suppliers, but the Contractor shall ascertain that Submittals meet all of the requirements of the Contract Documents, while conforming to structural, space, and access conditions at the point of Installation. The Contractor shall check all Submittals before submitting them to the Director.

2-1.08A **SHOP DRAWINGS.** The Contractor shall submit an electronic copy (searchable PDF) of all Shop Drawings required by the Supplemental Conditions or Specifications, and one (1) hard copy, if requested by the Director. Shop Drawings shall also be provided separately in AutoCAD format using the latest version of AutoCAD. An electronic

copy will be returned to the Contractor either approved for use, as demonstrated by a stamp, or returned for correction and resubmittal. Materials, colors and/or samples will not be returned to the Contractor. Shop Drawings include any drawing, which requires execution by a draftsman as distinguished from printed matter. The size of Shop Drawings shall not exceed twenty-four inches (24”) by thirty-six inches (36”).

2-1.08B **DESCRIPTIVE DATA.** The Contractor shall submit an electronic copy (searchable PDF) of each set of manufacturer's brochures or other data required by the Supplemental Conditions or Specifications, and one (1) hard copy, if requested by the Director. The City will examine such Submittals and return either an electronic copy or a hard copy approved for use or returned for correction and resubmittal.

2-1.08C **SAMPLES.** The Contractor shall submit samples of articles, materials or equipment as required by the Supplemental Conditions or Specifications. The Work shall be in accordance with the approved samples. Samples shall be removed from City property when directed or may be incorporated in the Work if approved by the Director. Samples not removed by the Contractor will become the property of the City or, at the City's option, will be removed or disposed of by the City at the Contractor's expense.

2-1.08D **MANUALS, INSTRUCTIONS AND AFFIDAVIT.**

A. **Manuals and Instructions.** Where operation and maintenance manuals are required by the Supplemental Conditions, the Contractor shall submit two (2) sets of manuals, suitably bound, along with two (2) electronic copies in an approved format, to the Director within forty-five (45) Days after favorable review of the equipment or facilities. If operation and maintenance manuals are approved to be provided in PDF format, text shall be provided in searchable PDF format, making proper use of PDF for headings and heading levels,

paragraphs, tables, and lists. Submitted operation and maintenance manuals shall be a collected, organized, and indexed set of bookmarked PDF documents comprising each operation and maintenance manual that corresponds to a hardcopy binder. All manuals shall be marked to indicate the specific equipment furnished for this project and shall include at a minimum:

1. Equipment summary form
2. Cover/Title page
3. Table of contents
4. Operating procedures including start-up, shutdown, normal operation, all operating modes, emergency shutdown, and safety precautions
5. Lubrication instructions (if required)
6. Preventative maintenance procedures
7. Troubleshooting and corrective maintenance procedures
8. Reinstallation instructions
9. Overhaul instructions (if applicable)
10. Parts identification list with exploded view and associated cross references
11. Recommended spare parts list
12. Operator safety requirements
13. Electrical and control system wiring drawings, including panel wiring control (ladder) diagrams, logic diagrams, loop diagrams, and interconnection diagrams
14. Panel layout and assembly drawings

15. Mechanical drawings
16. Printouts of all software programs and configuration files
17. Factory and field test procedures and results

Operation and maintenance manuals for complex equipment shall also include:

18. Alternate specified operating modes
19. Emergency shutdown instructions
20. Normal shutdown instructions
21. Long term shutdown instructions

Operation and maintenance manuals for systems comprised of separate pieces of equipment shall include a system explanation of items 4, 7, 18, 19, 20, and 21 as well as the instructions for the separate pieces of equipment.

B. Affidavits. Where required in the Supplemental Conditions or Specifications, manufacturers of equipment shall provide field service as a part of this project. Equipment shall not be considered ready for full time operation until after the authorized factory-trained and qualified manufacturer's representative for the specific equipment has checked and adjusted the equipment and certified by written affidavit that the equipment has been properly installed, tested, adjusted, lubricated, and calibrated, and is ready for full time operation. Acceptable affidavits shall be submitted prior to completion of the Work. Affidavits shall contain the following specific wording:

“The (Name of Equipment) has been properly installed, tested, adjusted, lubricated, and calibrated, and is ready for full time operation. The installation has been inspected and has been found to be in conformance with our (the manufacturer's) standards and requirements.”

No amplification, dilution, or modification of this specific wording will be permitted.

2-1.08E **ALTERNATIVES.** For convenience in designation in the Contract Documents, certain materials, articles, or equipment may be designated by a brand or a trade name or the name of the manufacturer together with catalog designation or other identifying information, hereinafter referred to generically as “designated by brand name.” Except in those instances where the product is designated to match others in use in a particular improvement, either completed or in the course of completion, an alternative material, article, or equipment which is of equal quality and of the required characteristics for the purpose intended may be proposed for use provided the Contractor complies with the following requirements:

A. The Contractor shall submit its proposal for an alternative in writing. Such request shall be made in ample time to permit review and approval without delaying the Work. The Contractor shall not be entitled to an adjustment of the Contract Time or an increase in the Contract Price based on any Contractor-proposed substitution.

B. No such proposal will be considered unless accompanied by complete information and descriptive data, necessary to determine the equality of the offered materials. The Contractor shall satisfy the Director as to the comparative quality, suitability, or performance of the offered material, articles, or equipment. In the event that the Director rejects the use of such alternative materials, articles, or equipment, then one of the particular products designated by brand name shall be furnished.

C. The burden of proof as to the quality and suitability of alternatives shall be upon the Contractor and it shall furnish all information necessary as required by the Director. The Director shall be the sole judge as to the quality and suitability of alternative articles or materials and such decisions shall be final. Where use of an alternative material

involves redesign of, or changes to, other parts of the Work, the cost and time required to effect such redesign or changes will be considered in evaluating the suitability of the alternative material. Cost of redesign by the City will be borne by the Contractor.

D. Whenever classification, rating or other certification by a body such as Underwriters Laboratories (UL) or the National Electrical Manufacturers Association (NEMA) is a part of the specification for any material, Contractor's request for use of alternative articles or materials shall be accompanied by reports from the listed or equivalent independent testing Laboratory indicating compliance with the Contract Documents. The cost of all testing required to prove equality of the material proposed shall be borne by the Contractor. Approval of an alternative shall be only for the characteristics or use named in such approval, and shall not be used to change or modify any requirement of the Contract Documents.

E. At its election, the City reserves the right to consider any Contractor proposed substitution as a Cost Reduction Proposal under Section 3-1.07 of these General Conditions in the event that there is a significant savings resulting from the substitution.

The Director will examine, with reasonable promptness, such Submittals, and return of Submittals to the Contractor shall not relieve the Contractor from responsibility for deviations and alternatives from the Contract Documents, nor shall it relieve the Contractor from responsibility for errors in the Submittals. A failure by the Contractor to identify in its letter of transmittal material deviations from the Contract Documents shall void the Submittal and any action taken thereon by the Director. When specifically requested by the Director, the Contractor shall resubmit such Shop Drawings, descriptive data and samples as may be required.

If any mechanical, electrical, structural, or other changes are required for the proper Installation and fit of alternative materials, articles, or equipment, or because of deviations from

the Contract, such changes shall not be made without the approval of the Director and shall be made without additional cost to the City.

2-1.09 **DISPOSAL OF MATERIAL OUTSIDE THE WORK SITE.** Unless otherwise stated elsewhere in the Contract Documents, the Contractor shall, at its own cost and expense, make its own arrangements for disposing of materials outside the Work Site.

Except when material is to be disposed of at a landfill or recycling center, when any material is to be disposed of outside the Work Site, the Contractor shall first obtain written permission from the City to dispose of the material at the intended location. The City's approval will be contingent upon the Contractor obtaining a written permit from the property owner on whose property the disposal is to be made. Prior to the disposal of any material at the intended location, the Contractor shall submit such permit or a certified copy thereof to the City, together with a written release from the property owner absolving the City from any and all responsibility related to the disposal of material on said property.

Disposal of Hazardous Materials must be done in accordance with all laws and regulations. Copies of all required regulatory documentation including copies of final manifests shall be supplied to the City.

2-1.10 **ACCESS TO THE WORK.** The Contractor shall satisfy itself that the jurisdictions through which its operations and haul routes pass will permit such operations with respect to the type of vehicle, laden weights, frequency and dimensions of loads, hours of operation and required traffic control. All necessary permits, licenses or bonds shall be obtained and paid for by the Contractor.

2-1.11 **TEMPORARY UTILITIES.** The Contractor shall make its own arrangements with utility companies for any temporary services it may require in performance of

the Work and shall pay all costs of these services directly to these utility organizations.

2-1.12 **UTILITY FACILITIES.** The Contractor shall protect from damage those utility facilities that are to remain in place, be Installed, relocated or otherwise arranged.

The Contractor's attention is directed to the possible existence of facilities not shown, and of facilities in a location different from that, which is indicated. The Contractor shall take steps to ascertain the exact location of all facilities prior to doing any Work, which may damage such facilities or interfere with their service. Where the location of a facility is indicated or inferred from the presence of visible facilities such as buildings, meters, and junction boxes, the Contractor shall make such excavations and explorations as are necessary to ascertain the correct location. Unless provided for elsewhere in the Contract Documents, the cost of such excavations and explorations will be considered as a part of the cost of other items of Work and no additional payment will be made. Such excavations and exploratory Work shall not entitle the Contractor to an extension of time.

If the Contractor discovers underground facilities not indicated or inferred from the Contract Documents, the Contractor shall immediately give the Director written notification of the existence of those facilities. The Contractor shall determine the exact location of the underground facilities and the cost of the work will be paid for in accordance with the Contract Documents. The underground facilities shall be protected from damage as directed by the Director and the cost of that work will be paid for as extra work. The Contractor shall, if directed by the Director, repair any damage, which may occur to the underground facilities. The cost of that repair work, not due to the failure of the Contractor to exercise reasonable care, will be paid for as extra work. Damage due to the Contractor's failure to exercise reasonable care shall be repaired at the Contractor's cost and expense.

Where it is determined by the City that the rearrangement of an underground facility, the existence of which is not shown on the Contract Drawings, is essential in order to accommodate the Work, the City will provide for the rearrangement of such facility by other forces or, when so ordered by Change Order, such rearrangement shall be performed by the Contractor and will be paid for as provided under a Change Order.

The Contractor shall be responsible for the maintenance of all utility facilities placed by the Contractor in temporary locations, and all utilities within the construction area not required to be relocated but which are required to be shored or supported during the construction period. The cost of such maintenance shall be borne by the Contractor, and no other compensation shall be due the Contractor for this Work.

The cost of providing and maintaining all necessary or required temporary structures, of making any necessary repairs, replacements, or similar operations, or furnishing indemnity or other bonds, if required, and all costs required by this Section shall be paid by the Contractor and shall be included in the prices bid in the schedule for other items of work.

2-1.13 **PRESERVATION AND CLEANING.** The Contractor shall clean up the Work at frequent intervals and at other times when directed by the Director. While finish Work is being accomplished, floors, Work areas and finished areas shall be kept clean, free of dust, construction debris and trash. Upon completion of the Work, the Contractor shall remove from the Premises its construction equipment and any waste materials not previously disposed of, leaving the Premises thoroughly clean and ready for final inspection.

2-1.14 **LIMITATIONS ON WORK SITE AND PREMISES.** The Contractor shall limit its construction operations to the Work Site unless otherwise shown on the Contract Drawings or specified. The Contractor shall perform no operation of any nature over or on the

Premises except such operations as are authorized by the Contract Documents or as authorized by the Director.

2-1.15 **DUST CONTROL.** During the performance of all Work under this Contract, the Contractor shall assume all responsibility for dust control and shall furnish all labor, equipment, and means required to carry out proper and efficient measures wherever and whenever dust control is necessary to prevent the operations from producing dust damage and nuisance to persons and property. Any claims resulting from dust damage or nuisance shall be borne solely by the Contractor. The Contractor shall comply with all applicable Air Quality Act requirements.

2-1.16 **SANITATION.** The Contractor shall provide sanitary facilities for all persons working on the Work.

2-1.17 **NIGHT WORK AND NORMAL WORKING HOURS.** Normal working hours at the construction site shall be between the hours of 7:00 a.m. and 7:00 p.m. Monday through Friday. Legal holidays are excluded. Certain utility connections and street operations are anticipated to require night Work by the Contractor during low usage periods. The Contractor may also be required to prosecute the Work at night if, at any time, the Director shall deem it necessary for the progress of the Work, or if emergencies arise. The Contractor shall promptly comply with any such requirements made in writing by the Director. The Contractor will also be permitted to Work at night if Contractor satisfies the Director of the need therefor, in order to maintain the required progress or protect the Work from the elements. Certain activities are required to be performed at night for nominal progress of the Work and/or are specified to be performed at night by other portions of the Supplemental Conditions. When required, ordered, or permitted to Work at night, the Contractor shall provide sufficient and

satisfactory lighting and other facilities therefor. The Contractor shall receive no extra payment for night Work, if specified or if required to be performed during the normal progress of the Work, but compensation shall be considered as having been included in the price stipulated for the Work.

If Contractor performs work during weekends, holidays or any non-normal work hours, Contractor shall pay for required City Inspectors.

2-1.18 **LINES AND GRADES.** Unless otherwise provided in the Supplemental Conditions, the Contractor shall lay out all Work, including structures and pipelines, and shall be responsible for any errors resulting therefrom. In all questions arising as to proper location of lines and grades, the Director's decision will be final.

As part of the bid price for the construction of the improvements, the Contractor shall provide and be responsible for the layout of all Work on this project. The Contractor shall provide all necessary surveys, field staking, and positioning for the construction of all components at the proper alignment, elevations, grades, and positions, as indicated on the Contract Drawings and as required for the proper operation and function. The Contractor shall stake its Work area limits. Contractor shall perform all construction staking using a land surveyor licensed in the State of California. Contractor shall provide a staking plan prior to commencement of Work for the City's review and maintain monuments, stakes, and marks, and shall update the plan as necessary. Director, or Director's designated representative, may verify the field condition. Errors or inconsistencies in the Contract Documents discovered by the Contractor shall be reported to the Director within twenty-four (24) hours and prior to constructive forms or related improvements. Any work Installed with this requirement shall be subject to removal and replacement at the Contractor's expense.

The Contractor's lay-out shall be based on existing structures, property lines, survey control, and bench marks established by the City. All structures and pipeline connections shall be Installed based on actual elevation of existing structures to which connections are made.

The Contractor shall supply such labor as required, at no extra charge, to aid and assist the Director in checking location and grades of the Work as set by the Contractor if the Director desires to perform this checking. This shall include moving materials and equipment located between monuments and the construction Work.

2-1.19 **ARCHEOLOGICAL DISCOVERIES.** Upon discovery of prehistoric or historic artifacts, or other indicators or examples of cultural resources discovered during the course of site preparation, grading, excavation, construction or other development activities, all operations within fifty feet (50') of the find shall cease until such time as the City provides the services of a qualified archeologist to evaluate the finds and recommend appropriate action.

Prehistoric materials can include flaked stone tools (e.g., projectile points, knives and choppers) or tool making debris of obsidian, chert, quartzite and other materials, culturally darkened soil (i.e., midden, which often contains heat affected rock, ash and charcoal, shellfish remains, and cultural materials), and stone milling equipment such as mortars, pestles and hand stones. Historic material may include wood, stone, concrete or adobe footings, walls and other structural remains; debris filled wells or privies; and deposits of wood, metal, glass, ceramics and other refuse.

2-1.20 **PRESERVATION OF MONUMENTS.** Any monuments or bench marks disturbed by construction operations shall be repaired per the City's standard and promptly re-established by a registered land surveyor or civil engineer. A plat for each monument shall be furnished to the Director after the plat has been recorded with the Placer

County Recorder's Office at no additional cost to the City. The recorded plat shall serve as a record of the re-establishment of said existing survey points.

2-1.21 **CONFORMITY WITH CONTRACT DOCUMENTS.** Work and materials shall conform to the lines, grades, cross sections, dimensions and material requirements, including tolerances, required by the Contract Documents. Although measurement, sampling and testing may be considered evidence as to such conformity, the City shall be the sole judge as to whether the Work or materials deviate from the Contract Documents. At its option, the City may elect to accept deviations from the Contract Documents with appropriate backcharge Assessments against the Contractor, and, if such an election is made, the City will provide written notice to the Contractor of such acceptance.

2-1.22 **FINAL CLEANUP.** Prior to final Acceptance of the Work, the Contractor shall thoroughly clean the Premises, remove all temporary structures built by or for the Contractor, and remove all equipment and surplus construction material and debris from the area. The entire project, before Acceptance by the City, shall be left in a neat and clean condition. All Work areas and temporary construction areas shall be returned to essentially the same conditions existing before the commencing of project construction.

2-1.23 **AS-BUILT DOCUMENTS AND DRAWINGS.** The Contractor shall maintain one set of the full size prints furnished by the City and mark thereon in color any deviations from plan dimensions, elevations, or orientations. Also, the Contractor shall locate on said prints, all underground facilities, such as piping, conduits and tanks by accurate field measurement from structure walls, corners, etc. The Contractor shall submit the prints and an electronic CD (searchable PDF or source file format such as AutoCAD) in good condition to the Director upon completion of the job as a condition of Acceptance of the project. Marked prints

shall be updated at least once each week and shall be available to the Director for review as to currency prior to developing partial payment estimates. After the completion of testing, but prior to Acceptance, the Contractor shall submit As-Built electrical drawings in color and an electronic CD showing all components and their wiring, and as specified in the Supplemental Conditions.

2-1.24 **SUPERINTENDENCE.** The Contractor shall supervise and direct the Work, which shall be performed in accordance with the requirements of the Contract Documents. The Contractor shall be solely responsible for implementation of all construction means, methods, techniques, sequences, and procedures and for coordination of all portions of the Work under the Agreement. The Contractor shall be solely responsible for the safety of its employees, Subcontractors of any tier, Suppliers, visitors to the Contractor, and other third parties associated with the Contractor.

The Contractor shall designate in writing before starting Work, an authorized representative who shall have the authority to represent and act for the Contractor.

When the Contractor is comprised of two (2) or more persons, firms, partnerships, or corporations functioning on a joint venture basis, said Contractor shall designate in writing before starting Work, the name of one authorized representative who shall have the authority to represent and act for the Contractor. Instances of misconduct, contract non-compliance, unsatisfactory performance, or incompetence by these personnel shall be grounds for the City to direct Contractor to dismiss them from the Project. Contractor shall immediately comply with the City's request for dismissal, at no cost to the City, and shall designate a replacement, which shall be subject to approval by the City.

Said authorized representative shall be present at the site of the Work at all times while Work is actually in progress on the Contract. When Work is not in progress and during periods

when Work is suspended, arrangements acceptable to the Director shall be made for any Emergency Work that may be required.

Whenever the Contractor or its authorized representative is not present on any particular part of the Work where it may be desired to give direction, orders will be given by the Director, which shall be received and obeyed by the superintendent or foremen who may have charge of the particular Work in reference to which the orders are given.

Any order given by the Director, not otherwise required by the Supplemental Conditions to be in writing, will on request of the Contractor, be given or confirmed by the Director in writing.

2-1.25 **CHARACTER OF WORKER.** If any Subcontractor or person employed by the Contractor shall appear to the Director to be incompetent or to act in a disorderly or improper manner, he or she shall be removed immediately on the requisition of the Director, and such person shall not again be employed on the Work.

2-1.26 **INSPECTION.** The Contractor shall at all times permit the Director to inspect the Work or any part thereof. The Contractor shall maintain proper facilities and provide safe access for such inspection by the Director to all parts of the Work, and to the shops where the Work is in preparation. Work shall not be covered up until authorized by the Director and the Contractor shall be solely responsible for notifying the Director where and when such Work is in readiness for inspection and testing. Should any such Work be covered without authorization, it shall, if so ordered, be uncovered at the Contractor's expense.

Unless otherwise designated as normal working hours, whenever the Contractor intends to perform Work on Saturday, Sunday, or a Legal Holiday, the Contractor shall give notice to the Director of such intention forty-eight (48) hours prior to performing such Work, or such longer

period as may be specified so that the Director may make necessary arrangements.

The observation and/or approval of the workmanship or materials by the City shall not relieve the Contractor of any obligations to fulfill the requirements of the Contract Documents. Workmanship and materials not meeting such requirements shall be corrected and unsuitable Work or material may be rejected, notwithstanding that such Work or materials have been previously observed and/or approved by the City, or payment therefor has been included in a progress estimate.

The City may order re-examination of questioned Work at any time before final Acceptance. If so ordered, the Contractor shall uncover the Work. If such work is found to be in accordance with the Contract Documents, the City will pay for the cost of uncovering, removing, recovering and replacing the parts removed; but if such Work so exposed or examined is not in accordance with the Contract Documents, the uncovering, removal, recovering and replacement shall be at the Contractor's expense. Work that has been covered prior to observation by the City does not qualify as re-examined work; the City may order such work uncovered for observation without payment of any costs.

2-1.27 **REMOVAL OF REJECTED AND UNAUTHORIZED WORK.** All Work which has been rejected shall be remedied, or removed and replaced by the Contractor in a manner acceptable to the Director and no compensation will be allowed the Contractor for such removal, replacement, or remedial Work.

Any Work done beyond the lines shown on the Contract Drawings or established by the Director, or any Work done without written authority will be considered as unauthorized Work and will not be paid for. Upon order of the Director, unauthorized Work shall be remedied, removed, or replaced at the Contractor's expense.

Upon failure of the Contractor to comply promptly with any order of the Director made under this section, the Director may cause rejected or unauthorized Work to be remedied, removed, or replaced, and the costs thereof will be deducted from any moneys due or to become due the Contractor.

SECTION 3

CHANGES IN THE WORK

3-1.01 **CHANGES.** The Director, without invalidating this Agreement and without notice to Contractor's surety, may order changes in the Work, consisting of additions or deletions, or other revisions. The Contract Price and the Contract Time shall be adjusted accordingly. All such changes in the Work, including in the Contract Price and the Contract Time, shall be authorized only by Contract Change Order, signed by the Director.

If Contractor claims that performance of any work entitles it to additional compensation or to an extension of time for performance of the Work, Contractor shall provide written notice to the City of any such claim prior to undertaking such work. Contractor shall provide written notice of any anticipated impacts to the Contract Price or Contract Time within three (3) Days of discovering such impact, by submitting a Notice of Potential Claim described in Section 7-1.03 below, or notice of delay as described in Section 6-1.09 below. If the Director refuses to issue a Change Order for such work, Contractor shall perform that work if directed or obligated to do so and shall submit a complete and specific Claim for additional compensation and/or extension of time for performance within fifteen (15) Days after such work is performed, as described in Section 7-1.03 below. Failure to provide written notice of claims prior to undertaking such work, failure to provide a timely Notice of Potential Claim, or failure to submit timely a complete and specific Claim for additional compensation and/or extension of the time for performance, shall be deemed a waiver and abandonment of any such Claim. No Claim, dispute or controversy shall interfere with the progress or performance of the Work and the Contractor shall proceed with the Work as directed by the Director. Failure to so proceed shall amount to a

default under this Agreement.

3-1.02 **PROPOSED CHANGE ORDERS.** The Contractor will be notified in writing of a proposed Change Order describing the intended change. Within fifteen (15) Days after receipt of a written request, the Contractor shall submit its proposed price to be added or deducted from the Contract Price due to the change and its estimate of the extent of the adjustment in the Contract Time, if any. The Contractor's proposed price to be added to or deducted from the Contract Price shall be supported by a detailed estimate of cost prepared by the Contractor, vendor or Supplier. The Contractor's proposed price submittal shall be accompanied by a statement of the time necessary for the changed Work, together with a description of how this time will be incorporated into the current Construction Schedule. The Contractor shall upon request by the Director permit inspection of its original Contract estimate, subcontract agreements or purchase orders relating to the change.

If agreement is reached on the adjustment in compensation as provided in Section 3-1.05, "Contract Price Adjustment," of these General Conditions, the Contractor shall proceed with the Work as changed at the agreed price.

If the Contractor and the Director fail to agree as to the adjustment in compensation for the performance of the changed Work, the Contractor, upon written order from the Director, shall proceed immediately with the changed Work and the Contract Price shall be adjusted in accordance with Section 3-1.06, "Force Account Payment," of these General Conditions.

If the Contractor fails to submit its cost estimate within such fifteen (15) Day period, the Contractor shall commence the Work as changed immediately upon receipt of written order of the Director, and the Contract Price will be adjusted in accordance with the Director's cost estimate for the changed Work.

3-1.03

EMERGENCY AND INDETERMINATE TYPE CHANGE

ORDERS. Changes in the Work made necessary by an Emergency, as determined by the Director, or changes of a kind where the extent of the Work cannot be determined until completed, may be authorized by the Director in writing. The Change Order shall state that it is issued pursuant to this Section 3-1.03. Upon receipt of an authorized Change Order or other written order of the Director, the Contractor shall proceed with the ordered Work and the Director will maintain a daily job record containing a detailed summary of all labor, materials and equipment required for the changed Work.

Within fifteen (15) Days after receiving a written request, the Contractor shall submit a detailed estimate of cost for the change and any requested change in Contract Time in the same manner as required for proposed Change Orders in Section 3-1.02 of these General Conditions.

3-1.04

EXECUTED CHANGE ORDER.

A Contract Change Order signed by both the Director and the Contractor is an “executed Contract Change Order.” By signing the Contract Change Order, the Contractor agrees that the specified compensation constitutes full compensation for the changed Work, including payment for interruption, disruption, acceleration, extended Overhead, delay or any other “impact” claim or “ripple effect” claim. The Contractor specifically understands and agrees that its execution of the Contract Change Order shall constitute a waiver of any right for the Contractor to claim any additional compensation with respect to the subject matter of the Contract Change Order.

3-1.05

CONTRACT PRICE ADJUSTMENT.

If a Contract Change Order provides for an adjustment to the Contract Price, the amount of such adjustment shall be determined by one of the following methods, or a combination thereof, as determined by the City and in its sole discretion:

A. Lump sum. The Contractor and the City may agree on a lump sum amount for the Change Order. At the City's request, the Contractor will provide pricing for the work. Maximum markups for Contract Change Orders paid for using lump sum pricing shall be paid for in the same manner and in the same amounts as markups for Force Account work, as described in Section 3-1.06 below.

B. Unit Prices. The unit prices set forth in the Contractor's Schedule of Bid Prices will be utilized where they are applicable and acceptable to the City. The Contractor's unit prices shall remain firm and shall not be subject to adjustment unless and until the actual quantity of work is increased or decreased by Contract Change Order in an amount greater than twenty-five percent (25%) from the estimated quantity indicated for such item. No markups will be given for Contract Change Orders paid for using unit prices.

Unit prices for new items included in the Contract Change Order but not included in the original bid shall be as mutually agreed upon or, in the absence of agreement, as determined by the City in the same manner as if the work were to be paid for on a Force Account basis, as described in Section 3-1.06 below.

C. Force Account. Where the City and the Contractor are unable to agree on lump sum pricing and if the City does not elect to utilize the unit prices in Contractor's bid, or such unit prices are not applicable, the changed work will be performed and tracked by the Contractor as Force Account work, as described in Section 3-1.06 below. The City will pay for such work, including markups, properly attributable to the change in accordance with those Force Account provisions.

D. Eliminated Items. The City reserves the right to delete any bid item of Work in its entirety. The City makes no representation that any work under a bid item of Work

will be performed, and all work may be subject to a Contract Change Order that deletes such work. Bid items are distinct and severable from the other bid items, and the Contractor shall not be entitled to any anticipated profit, unabsorbed Overhead, or other indirect expense attributable to the deleted item, except as provided immediately below with regard to Force Account mark-ups on the direct and verifiable costs incurred prior to the City's order that deletes the work.

Should any bid item of Work be eliminated in its entirety and not accounted for as described immediately above and, in the absence of an executed Contract Change Order covering such elimination, payment will be made to the Contractor for actual direct and verifiable costs incurred in connection with such eliminated bid item if incurred prior to the date of notification in writing by the City of such elimination. If acceptable material is ordered by the Contractor for the eliminated item prior to the date of notification of such elimination by the City, and if orders for such material cannot be canceled, it will be paid for at the actual direct and verifiable cost to the Contractor. Actual direct costs shall include documented vendor shipping fees, Supplier restocking fees, if applicable, and Contractor handling costs directly related to the eliminated item(s). In such case, the material paid for shall become the property of the City and the actual cost of any further handling will be paid for by the City. If the material is returnable to the vendor and if the City so directs, the material shall be returned and the Contractor will be paid for the actual direct cost of charges made by the vendor for returning the material. The actual direct cost of handling returned materials will also be paid for by the City. The actual direct and verifiable costs to be paid by the City as provided herein will be computed in the same manner as if the work were to be paid for on a Force Account basis, including the application of Force Account mark-ups to said costs.

3-1.06 **FORCE ACCOUNT PAYMENT.** When Work performed pursuant to a

Change Order is to be paid for on a Force Account basis, the Contractor's labor, materials and equipment used in the performance of such Work shall be subject to the approval of the City, and the compensation will be determined as set forth below in this section.

3-1.06A **LABOR.** The Contractor will be paid an amount based on the actual cost for the workers (including foremen when authorized by the Director) used in the actual and direct performance of the Work. All labor costs associated with Overhead, whether field or home office, are specifically excluded herein, as those labor costs are covered by the below mark-ups. The cost of labor, whether the employer is the Contractor, Subcontractor or other forces, shall include employer payments; assessment of benefits required by lawful labor union collective bargaining agreements; compensation insurance payments; contributions made to the State pursuant to the Unemployment Insurance Code; and for taxes paid to the Federal Government pursuant to the Social Security Act of August 14, 1935, as amended. No labor cost will be recognized at a rate in excess of the wages prevailing in the locality at the time the Work is performed, nor will the use of a labor classification, which would increase the cost, be permitted unless the Contractor establishes to the complete satisfaction of the Director the necessity for payment at a higher rate.

3-1.06B **MATERIALS.** Only materials furnished by the Contractor and necessarily used in the performance of the Work will be paid for. Such cost of materials may include the costs of procurement, transportation and delivery if necessarily incurred. If a cash or trade discount by the actual supplier is available to the Contractor, it shall be credited to the City. If materials are procured by the purchaser by any method which is not a direct purchase from and a direct billing by the actual supplier to such purchaser, the cost of such materials shall be deemed to be the price paid to the actual supplier plus the actual costs, if any, incurred in the

handling of such materials. If the materials are obtained from a supply or source owned wholly or in part by the purchaser, the cost of such materials shall not exceed the price paid by the purchaser for similar materials furnished from said source on Bid items or the current wholesale price for such materials delivered to the job site, less any discounts as provided herein, whichever is lower. If, in the opinion of the Director, the cost of materials is excessive, or if the Contractor fails to furnish satisfactory evidence of the cost to it from the actual supplier within sixty (60) Days after the date of delivery of the materials or within fifteen (15) Days after Acceptance of the Agreement, whichever occurs first, the cost of the materials shall be deemed to be the lowest current wholesale price at which similar materials are available in the quantities required, less any discounts provided herein. The Department reserves the right to furnish such materials required by the Change Order as it deems advisable, and the Contractor shall have no claim for cost or markups on material furnished by the Department.

3-1.06C **EQUIPMENT.** The Contractor will be paid an amount based on the actual cost for the use of equipment directly required and approved by the Director in the performance of the changed Work. No payment will be made for time while equipment is inoperative due to breakdowns or on Days when no Work is performed. In addition, the rental time shall include the time required to move the equipment to the Work from the nearest available source of such equipment, and to return it to the source. If such equipment is not moved by its own power, then loading and transportation costs will be paid. Moving time, loading and transportation costs will only be paid if the equipment is used exclusively on the changed Work during the time between move in and move out. Individual pieces of equipment having a replacement value of One Thousand Dollars (\$1000) or less shall be considered to be tools or small equipment, and no payment will be made therefore. For equipment owned,

furnished, or rented by the Contractor, no cost therefore shall be recognized in excess of the equipment rental rates published by Caltrans at the following website address:

<http://www.dot.ca.gov/hq/construc/equipmnt.html>. Equipment located at a Work Site and utilized on non-Force Account work shall not be eligible for standby payment, and shall be charged on a Force Account basis only when solely performing pre-approved Force Account work tasks.

3-1.06D **MARKUPS.** When a Change Order increases the cost of the Work, the Contractor may add the following maximum markups to its actual costs of labor, materials, or equipment rental:

- 15 percent for labor;
- 10 percent for materials; and
- 5 percent for equipment rental.

The above markups include full compensation, covering the costs of all supervision, bonds, profit, Overhead, and other general expenses not specifically designated as a direct cost in Sections 3-1.06A through 3-1.06C above. The total payment (i.e., direct cost plus applicable markups) shall be deemed to be the actual cost of such work and shall constitute full compensation therefor. The Contractor specifically understands and agrees that such payment shall include any Contractor costs for interruption, disruption, and acceleration, extended Overhead, Change Order management, delay or other “impact” claim or “ripple effect” claim.

When work paid for on a Force Account basis is performed by forces other than the Contractor’s own forces, the maximum allowable mark-ups for the Subcontractors’ costs shall be fifteen percent (15%) for the cost of labor, ten percent (10%) for the cost of materials, and five percent (5%) for the cost of rented equipment. In these situations where the work is being performed by Subcontractors, the Contractor will only be entitled to an additional five percent

(5%) mark-up and will not be entitled to receive the additional mark-ups specified in this section.

When a Change Order decreases the cost of the Work, the reduction in cost shall include a five percent (5%) markup on the estimated cost for furnishing the labor, materials and equipment, which would have been used on such Work, had the Change Order not been issued.

When a Change Order involves both added Work and deleted Work, the markup or markups to be used shall be as follows:

The actual costs of labor, materials, and equipment rental for added and deleted Work shall be calculated separately without adding markups. If the difference between the calculated costs for labor results in an increased cost, a markup of fifteen percent (15%) shall be applied to the increased cost. If the difference between the calculated costs of materials or equipment rental results in an increased cost, a markup of ten percent (10%) and five percent (5%) respectively, shall be applied to the increased costs of materials or equipment rental, as the case may be. If the difference between the calculated costs for labor, materials or equipment rental results in a decreased cost, a markup of five percent (5%) shall be applied to the decreased costs of labor, materials or equipment rental, as the case may be.

Contractor shall not add mark-ups on work performed and billed by City staff nor add mark-ups to successive iterations of proposed Change Order cost proposals returned to Contractor by the City due to incomplete or inaccurate information being originally submitted by the Contractor. If the Contract Price increases by the issuance of Change Orders, the penal amounts of the bonds required shall increase accordingly.

3-1.06E **RECORDS.** The Contractor shall maintain its records in such a manner as to provide a clear distinction between the direct costs of extra work paid for on a Force Account basis and the costs of other operations.

From the above records, the Contractor shall furnish the City completed daily extra work reports, on forms acceptable to the City, for each Day's extra work to be paid for on a Force Account basis. The daily extra work reports shall itemize the materials used, and shall cover the direct cost of labor and the charges for equipment rental, whether furnished by the Contractor, Subcontractor, or other forces. The daily extra work reports shall provide names and identifications and classifications of workers, the hourly rate of pay and hours worked, and also the size, type, and identification number of equipment, and hours operated. Daily extra work and Force Account reports (actual or claimed) shall be signed by both the City's and the Contractor's representatives within twenty-four (24) hours of the performance of the work.

Valid copies of vendor's invoices shall substantiate material charges. Such invoices shall be submitted with the daily extra work reports, or if not available, they shall be submitted with subsequent daily extra work reports. Should said vendor's invoices not be submitted within sixty (60) Days after the date of delivery of the material or within fifteen (15) Days after the Acceptance of the Agreement, whichever occurs first, the City reserves the right to establish the cost of such materials at the lowest current wholesale prices at which said materials were available in the quantities, less any discounts.

The City will compare its records with the completed daily extra work reports furnished by the Contractor and make any necessary adjustments. When these daily extra work reports are agreed upon and signed by both parties, said reports shall become the basis of payment for the work performed, but shall not preclude subsequent adjustment based on a later audit by the City.

The Contractor's cost records pertaining to Work paid for on a Force Account basis shall be open to inspection or audit by representatives of the City during the life of the Agreement and for a period of not less than three (3) years after the date of Agreement completion and the

Contractor shall retain such records for that period. Where payment for materials or labor is based on the cost thereof to forces other than the Contractor, the Contractor shall make every reasonable effort to insure that the cost records of such other forces will be open to inspection and audit by representatives of the City on the same terms and conditions as the cost records of the Contractor. If an audit is to be commenced more than sixty (60) Days after the date of Acceptance of the Agreement, the Contractor will be given fifteen (15) Days' notice of the time when such audit is to begin.

3-1.07 **COST REDUCTION PROPOSALS.** The City encourages the Contractor to submit Cost Reduction Proposals whenever the Contractor identifies areas and/or instances in which there can be savings to the Work. Contractor may submit to the City, in writing, proposals for modifying the plans, Specifications or other requirements of the Agreement for the sole purpose of reducing the total cost of construction, including the time for completion of the Work. The City may consider such Cost Reduction Proposals and, if accepted, the Agreement will be equitably adjusted. The City has no obligation to consider or accept Cost Reduction Proposals.

SECTION 4
CONTROL OF MATERIALS

4-1.01 **MATERIALS.** The Contractor shall furnish all materials required to complete the Work, except materials that are designated in the Supplemental Conditions to be furnished by the City and materials furnished by the City in accordance with Section 3, “Changes in the Work,” of these General Conditions.

Unless otherwise specified in the Supplemental Conditions, materials furnished by the Contractor for incorporation into the Work shall be new. When the quality or kind of materials, articles, or equipment is not particularly indicated, then the quality or kind thereof shall be similar to those that are indicated.

Articles or materials to be incorporated in the Work shall be stored in such a manner as to insure the preservation of their quality and fitness for the Work, and to facilitate inspection.

All materials which do not conform to the requirements of the Contract Documents as determined by the Director, will be rejected whether in place or not. Rejected material shall be removed immediately from the site of the Work, unless otherwise permitted by the Director. No rejected material, the defects of which have been subsequently corrected, shall be used in the Work, unless approval in writing has been given by the Director. Upon failure of the Contractor to comply promptly with any order of the Director made under these provisions, the Director shall have the authority to cause the removal and replacement of rejected material and to deduct the cost thereof from any moneys due or to become due the Contractor.

Manufacturer's warranties, guaranties, instruction sheets and parts lists, which are furnished with certain materials incorporated in the Work, shall be delivered to the Director

before Acceptance of the Contract.

Unless otherwise designated in the Supplemental Conditions or Specifications, materials furnished by the City will be delivered to the job site. Materials furnished by the City that are designated in the Supplemental Conditions as available at locations other than the job site shall be hauled to the site of the Work by the Contractor at its expense, including any necessary loading and unloading that may be involved.

The Contractor will be held responsible for all materials furnished to it, and shall pay all demurrage and storage charges. City-furnished materials lost or damaged from any cause whatsoever shall be replaced by the Contractor. The Contractor will be liable to the Department for the cost of replacing City-furnished material and such costs may be deducted from any moneys due or to become due the Contractor.

4-1.02 **PRODUCT AND REFERENCE STANDARDS.** When descriptive catalog designations, including manufacturer's name, product brand name, or model number are referred to in the Contract Documents, such designations shall be considered as being those found in industry publications in effect on the day the Notice to Contractors for the Work is dated, except as may be otherwise stated.

When standards or test designations of the Federal Government, trade societies, or trade associations are referred to in the Contract Documents by specific date of issue, these shall be considered as part of the Contract. When such references do not bear a date of issue, the edition in effect on the day the Notice to Contractors for the Work is dated shall be considered as part of the Contract.

4-1.03 **SAMPLING AND TESTING OF MATERIALS.** Unless otherwise specified, all tests shall be performed in accordance with the methods used by the State

Department of Transportation (Caltrans) and shall be made by the Director or his or her designated representative.

The State Department of Transportation has developed test methods for testing the quality of materials and Work. These test methods are identified by a California Test followed by the serial number. Copies of individual tests are available at the State Department of Transportation Laboratory, Sacramento, California, and will be furnished to interested persons upon request.

Whenever a reference is made in the Supplemental Conditions to a California Test by number, it shall mean the California test in effect on the day the Notice to Contractors for the Work is dated.

Whenever the Supplemental Conditions provide an option between two (2) or more test methods, the Director will determine the test method to be used.

Whenever a Supplemental Condition, manual, or test designation provides for test reports (such as certified mill test reports) from the manufacturer, copies of such reports, identified as to the lot of material, shall be furnished to the Director. The manufacturer's test reports shall supplement the inspection, sampling and testing provisions of this Section 4-1.03 and shall not constitute a waiver of the City's right to inspect. When material which cannot be identified with specific test reports is proposed for use, the Director may at his or her discretion, select random samples from the lot for testing. Testing specimens from the random samples, including those required for retest, shall be prepared in accordance with the referenced Supplemental Conditions and furnished by the Contractor at its expense. The number of such samples and test specimens shall be entirely at the discretion of the Director.

When requested by the Director, the Contractor shall furnish, without charge, samples of

all material entering into the Work, and no material shall be used prior to approval by the Director, except as provided in Section 4-1.04, "Certificates of Compliance," of these General Conditions.

A. Inspection and Access for Testing. The Contractor shall provide safe access for the Director and his or her inspectors to adequately inspect the quality of Work and conformance with the General and Supplemental Conditions. The Contractor shall provide adequate lighting, ventilation, ladders and other protective facilities as may be necessary for the safe performance of inspections.

The Contractor shall submit samples or specimens of such materials to be furnished or used in the Work as the Director may require. The Contractor shall furnish the Director all necessary labor and facilities for such things as excavation in the compacted fill to depths required to take samples.

Inspections, tests, or favorable review by the Director or others shall not relieve the Contractor from its obligations to perform the Work in accordance with the requirements of the Contract Documents.

Work covered without the favorable review or consent of the Director shall, if required by the Director, be uncovered for examination at the Contractor's expense.

If the Engineer, Architect, or Director considers it necessary or advisable that covered Work be inspected or tested by others, the Contractor, at the Director's request, will uncover, expose or otherwise make available for observation, inspection or testing as the Director may require, that portion of the Work in question, furnishing all necessary labor, materials, tools, and equipment. If it is found that such Work is defective, the Contractor will bear all the expenses of such uncovering, exposure, observation, inspection and testing and of

satisfactory reconstruction. If, however, such Work is not found to be defective and the Work was not covered without favorable review of the Director, the Contractor will be allowed an increase in the Contract Price or an extension of the Contract Time, or both, to cover its costs directly attributable to such uncovering, exposure, observation, inspection, testing, and reconstruction and an appropriate Change Order shall be issued.

Whenever the Contractor varies the period during which Work is carried on each Day, the Contractor shall give due notice to the Director so that proper inspection may be provided. Any Work done in the absence of the Director may be subject to rejection. Proper facilities for safe access for inspection to all parts of the Work shall at all times be maintained for the necessary use of the Director and other agents of the City. Authorized representatives and agents of the Director shall be permitted access to inspect all Work and materials wherever it is required for preparation of progress reports, and the Contractor shall provide proper facilities for such access and inspection.

It is the Contractor's responsibility to supervise the Work and complete the project in accordance with the Contract Documents. In the course of managing that effort, the Contractor shall generate its own punch lists as deemed necessary. The Director may prepare punch lists for the Director's own use in communicating with the Contractor; however, the Director shall be under no obligation to prepare punch lists for the Contractor. In general, the Director will prepare punch lists only after the Contractor has given the Director written notice that the subject Work is completed and tested in accordance with the Contract Documents and is ready for operation and/or use and/or occupancy. Failure of the Director to include an item in a punch list shall not relieve the Contractor of its duty to satisfactorily complete all Work required by the Contract Documents.

Upon Final Completion of the construction Work and request by the Contractor, the Director will conduct a final inspection as a basis for recommending to the City that the Work be accepted.

B. Field and Materials Testing. Where the Supplemental Conditions require Work to be specially field tested or approved, it shall be tested only in the presence of the Director after timely notice of its readiness for inspection and test, and the Work after testing shall be covered up only upon the consent thereto of the Director.

The results of any tests made are for the information of the Director. Regardless of any test results, the Contractor is solely responsible for the quality of workmanship and materials and for compliance with the requirements of the Contract Drawings and Supplemental Conditions.

Except as specifically required under the Supplemental Conditions, all tests by the Director of materials furnished by the Contractor will be done in accordance with commonly recognized standards of national organizations. The Contractor shall furnish such samples of all materials as required by the Director without charge. No material shall be used unless it has been favorably reviewed by the Director.

Where such inspection and testing are to be conducted by an independent Laboratory or agency, the sample or samples of materials to be tested shall be selected by such Laboratory or agency, or the Director, and not by the Contractor.

C. Costs of Testing.

1. Initial Services: The City shall furnish and pay for all initial testing services required by the Contract Documents. When initial tests indicate non-compliance with the Contract Documents, the cost of initial tests associated with that non-compliance will be

deducted by the City from the balance owed the Contractor. The Contractor shall furnish samples of materials for testing as may be required by the Director. Such samples shall be furnished without cost to the City.

2. Retesting: When initial tests indicate non-compliance with the Contract Documents, all subsequent retesting occasioned by the non-compliance shall be performed by the same testing Laboratory and the cost thereof will be deducted by the City from the balance owed the Contractor. Contractor shall be billed for each additional test.

3. Contractor Convenience Testing: Inspection or testing performed exclusively for the Contractor's convenience shall be the sole responsibility of the Contractor.

4. Additional Tests and Inspections: When in the opinion of the Director additional tests or inspections are required because of the manner in which the Contractor executes its Work, such tests and inspections shall be paid for by the City, but will be deducted from the Contract Price. Examples of such tests and inspections are tests of materials substituted for previously accepted materials or substituted for specified materials, retests made necessary by failure of material to comply with the requirements of the Specifications, load tests made necessary because of portions of the structure not fully meeting Specifications or plan requirements, etc.

4-1.04 **CERTIFICATES OF COMPLIANCE.** A Certificate of Compliance shall be furnished prior to the use of any materials for which the Supplemental Conditions require that such a Certificate be furnished. In addition, the Director may permit the use of certain materials or assemblies prior to sampling and testing if accompanied by a Certificate of Compliance. The Certificate shall be signed by the manufacturer of the material or the manufacturer of assembled materials and shall state that the materials involved comply in all

respects with the requirements of the Supplemental Conditions. A Certificate of Compliance shall be furnished with each lot of such materials delivered to the Work and the lot so certified shall be clearly identified in the Certificate.

All materials used on the basis of a Certificate of Compliance may be sampled and tested at any time. The fact that material is used on the basis of a Certificate of Compliance shall not relieve the Contractor of responsibility for incorporating material in the Work which conforms to the requirements of the Contract Documents and any such material not conforming to such requirements will be subject to rejection whether in place or not.

The Department reserves the right to refuse to permit the use of material on the basis of a Certificate of Compliance.

The form of the Certificate of Compliance and its disposition shall be as directed by the Director.

SECTION 5

LEGAL RELATIONS AND RESPONSIBILITY

5-1.01 **LAWS TO BE OBSERVED.** The Contractor shall keep informed of and observe, and comply with and cause all of its agents and employees to observe and comply with, all prevailing Federal and State laws, and rules and regulations made pursuant to said Federal and State laws, and county and municipal ordinances, and regulations, which in any way affect the conduct of the Contract. If any conflict arises between provisions of the Contract and any such law above referred to, the Contractor shall notify the Director at once in writing. To the fullest extent allowed by law, the Contractor shall defend, indemnify, and save and hold harmless the City or any of its officers, agents, employees, and volunteers against any claim or liability arising from or based on the violation of any such law, rule, or regulation, whether by itself or its agents or employees.

5-1.02 **HOURS OF LABOR.** Eight (8) hours labor constitutes a legal Day's work. The Contractor or Subcontractor shall, as a penalty to City, forfeit Twenty-five Dollars (\$25) for each worker employed in the execution of the contract by the respective Contractor or Subcontractor for each calendar day during which such worker is required or permitted to work more than eight (8) hours in any one (1) calendar day and forty (40) hours in any one (1) calendar week in violation of the provisions of the Labor Code, and in particular, Section 1810 to Section 1815, thereof, inclusive, except that Work performed by employees of Contractors in excess of eight (8) hours per day, and forty (40) hours during any one (1) week, shall be permitted upon public work upon compensation for all hours worked in excess of eight (8) hours per day at not less than one and one-half (1-1/2) times the basic rate of pay, as provided in said

Section 1815. In addition, Contractor and/or its Subcontractors may be required to pay double the basic rate of pay for all hours worked in excess of twelve (12) hours in any workday and under other circumstances. (See California Code of Regulations, Title 8, Sections 16100(c)(6) and (16200(a)(3)(F) and applicable Department of Industrial Relations prevailing wage determinations.)

5-1.03 **NONDISCRIMINATION.**

A. Attention is directed to Labor Code Section 1735, which reads as follows:

“A contractor shall not discriminate in the employment of persons upon public works on any basis listed in subdivision (a) of Section 12940 of the Government Code, as those bases are defined in Sections 12926 and 12926.1 of the Government Code, except as otherwise provided in Section 12940 of the Government Code. Every Contractor for public works who violates this section is subject to all the penalties imposed for a violation of this chapter.”

B. During the performance of this Contract, Contractor and its Subcontractors shall not unlawfully discriminate against any employee or applicant for employment because of race, religious creed, color, national origin, ancestry, physical disability, mental disability, medical condition, genetic information, marital status, sex, gender, gender identity, gender expression, age, sexual orientation, or military and veteran status. The Contractor and Subcontractors shall insure that the evaluation and treatment of their employees and applicants for employment are free of such discrimination. The Contractor and Subcontractors shall comply with the provisions of the California Fair Employment and Housing Act (Government Code §12900, et seq.) and the applicable regulations promulgated thereunder (California Code of Regulations, Title 2, §7285.0 et seq.) and other applicable State and Federal regulations and City

policies pertaining to nondiscrimination and affirmative action which are incorporated into this Agreement by reference and made a part hereof as if set forth in full. The Contractor and its Subcontractors shall give written notice of their obligations under this clause to labor organizations with which they have a collective bargaining or other agreement.

C. Contractor shall include the nondiscrimination and compliance provisions of this clause in all subcontracts to perform Work under the agreement.

5-1.04 **PREVAILING WAGE.** The Contractor and any Subcontractor shall comply with Labor Code Sections 1770 et seq. In accordance with said Section 1775 the Contractor and any Subcontractor under the Contractor shall, as a penalty, forfeit to the state or City not more than \$200 for each calendar day or portion thereof, for each worker paid less than the prevailing rate as determined by the Director of Industrial Relations for the work or craft in which such worker is employed for under the Contract by the Contractor or by any Subcontractor under the Contractor.

The amount of the penalty shall be determined by the Labor Commissioner based on consideration of both of the following: (a) whether the failure to pay the correct rate of per diem wages was a good-faith mistake and, if so, whether the error was promptly and voluntarily corrected when brought to the attention of the Contractor or Subcontractor; and (b) whether the Contractor or Subcontractor has a prior record of failing to meet its prevailing wage obligations.

The penalty may not be less than forty dollars (\$40) for each calendar day, or portion thereof, for each worker paid less than the prevailing wage rate, unless the failure of the Contractor or Subcontractor to pay the correct rate of per diem wages was a good faith mistake and, if so, the error was promptly and voluntarily corrected when brought to the attention of the Contractor or Subcontractor.

The penalty may not be less than eighty dollars (\$80) for each calendar day, or portion thereof, for each worker paid less than the prevailing wage rate, if the Contractor or Subcontractor has been assessed penalties within the previous three (3) years for failing to meet its prevailing wage obligations on a separate contract, unless those penalties were subsequently withdrawn or overturned.

The penalty may not be less than one hundred twenty dollars (\$120) for each calendar day, or portion thereof, for each worker paid less than the prevailing wage rate, if the Labor Commissioner determines that the violation was willful, as defined in subdivision (c) of Section 1777.1 of the Labor Code.

If the amount due under this section is collected from the Contractor or Subcontractor, any outstanding wage claim under Chapter 1 (commencing with Section 1720) of Part 7 of Division 2 of the Labor Code against the Contractor or Subcontractor shall be satisfied before applying that amount to the penalty imposed on that Contractor or Subcontractor pursuant to this section.

The determination of the Labor Commissioner as to the amount of the penalty shall be reviewable only for an abuse of discretion.

In addition to said penalty, the difference between such stipulated prevailing wage rates and the amount paid to each worker for each calendar day or portion thereof for which each worker was paid less than the stipulated prevailing wage shall be paid to each worker by the Contractor or Subcontractor.

If a worker employed by a Subcontractor on a public works project is not paid the general prevailing per diem wages by the Subcontractor, the Contractor is not liable for any penalties described above unless the Contractor had knowledge of that failure of the Subcontractor to pay

the specified prevailing rate of wages to those workers or unless the Contractor fails to comply with all of the following requirements:

1. The contract executed between the Contractor and the Subcontractor for the performance of work on the public works project shall include a copy of the provisions of Sections 1771, 1776, 177.5, 1813, and 1815 of the Labor Code.
2. The Contractor shall monitor the payment of the specified general prevailing rate of per diem wages by the Subcontractor to the employees, by periodic review of the certified payroll records of the Subcontractor.
3. Upon become aware of the Subcontractor's failure to pay its workers the specified prevailing rate of wages, the Contractor shall diligently take corrective action to halt or rectify the failure, including, but not limited to, retaining sufficient funds due the Subcontractor for work performed on the public works project.
4. Prior to making final payment to the Subcontractor for work performed on the public works project, the Contractor shall obtain an affidavit signed under penalty of perjury from the Subcontractor that the Subcontractor has paid the specified general prevailing rate of per diem wages to its employees on the public works project and any amount due pursuant to 1813 of the Labor Code.

Pursuant to Section 1775 of the Labor Code, the Division of Labor Standards Enforcement shall notify the Contractor on a public works project within fifteen (15) Days of the receipt by the Division of Labor Standards Enforcement of a complaint of the failure of a Subcontractor on that public works project to pay workers the general prevailing rate per diem wages.

Pursuant to the provisions of California Labor Code Section 1773, the City has obtained

the general prevailing rate of wages applicable to the categories of workers the City anticipates will be utilized for this project for straight time, overtime, Saturday, Sunday, and holiday Work. The holiday wage rate listed shall be applicable to all holidays recognized in the collective bargaining agreement of the particular craft, classification or type of worker concerned or, if no collective bargaining applies, those holidays identified in Government Code Section 6700. These wage rates may be obtained from the State Department of Industrial Relations and/or the following website address: <http://www.dir.ca.gov/dlsr/DPreWageDetermination.htm>, which is incorporated herein as a part of this Contract.

Pursuant to Labor Code Section 1773.2, the general prevailing wage rates set forth above, which forms a part of this Contract, shall be posted by the Contractor at a prominent place at the site of the Work.

Pursuant to Labor Code Section 1773.6 and California Code of Regulations Section 16204, Title 8, changes in general prevailing wage determinations shall apply to the project only if issued by the Director of Industrial Relations prior to the City's bid issuance date.

The City will not recognize any claim for additional compensation because of the payment by the Contractor of any wage rate in excess of the prevailing wage rate set forth in the Contract. The possibility of wage increases is one of the elements to be considered by the Contractor in determining its Bid, and will not under any circumstances be considered as the basis of a claim against the City or Contract.

When both California and Federal prevailing wage rates apply, the Contractor and any Subcontractors shall pay their workers the higher of the two rates. The Contractor and any Subcontractors shall insert this clause in any lower tier contract.

5-1.05 **REGISTRATION REQUIRED AS QUALIFICATION TO BID.**

Pursuant to Labor Code Section 1771.1(b), notice is hereby given that a Contractor or Subcontractor shall not be qualified to bid on, be listed in a bid proposal, subject to the requirements of Section 4104 of the Public Contract Code, or engage in the performance of any contractor for public work, as defined in Labor Code Sections 1720, et seq., unless currently registered and qualified to perform public work pursuant to Labor Code Section 1725.5. It is not a violation of Labor Code Section 1771.1 for an unregistered contractor to submit a bid that is authorized by Section 7029.1 of the Business and Professions Code or by Section 10164 or 20103.5 of the Public Contract Code, provided the contractor is registered to perform public work pursuant to Section 1725.5.

5-1.06 **PAYROLL RECORDS.** The Contractor's attention is directed to the following provisions of Labor Code Section 1776. The Contractor shall be responsible for the compliance with these provisions by its Subcontractors.

A. The Contractor and each Subcontractor shall keep accurate and current payroll records, showing the name, address, social security number, work classification, straight time and overtime hours worked each day and week, and the actual per diem wages paid to each journeyman, apprentice, worker, or other employee employed by it in connection with the public work. Each payroll record shall contain or be verified by a written declaration that is made under penalty of perjury, stating both of the following:

1. The information contained in the payroll record is true and correct.
2. The employer has complied with the requirements of Section 1771, 1811, and 1815 for any work performed by his or her employees on the public works project.

B. The payroll records enumerated under subdivision (A) shall be available for inspection at all reasonable hours at the principal office of the Contractor on the following

basis:

1. A certified copy of an employee's payroll record shall be made available for inspection or furnished to such employee or his or her authorized representative on request.

2. A certified copy of all payroll records enumerated in subdivision (A) shall be made available for inspection or furnished upon request to a representative of the City, the Division of Labor Standards Enforcement, and the Division of Apprenticeship Standards of the Department of Industrial Relations. The City reserves the right to withhold any progress payments to the Contractor in the event of noncompliance with the subsection.

3. A certified copy of all payroll records enumerated in subdivision (A) shall be made available upon request by the public for inspection or for copies thereof. However, a request by the public shall be made through either the City, the Division of Apprenticeship Standards, or the Division of Labor Standards Enforcement. The public shall not be given access to such records at the principal office of the Contractor.

C. The certified payroll records shall be on forms provided by the Division of Labor Standards Enforcement or shall contain the same information as the forms provided by the Division.

D. Each Contractor shall file a certified copy of the records enumerated in subdivision (A) with the entity that requested the records within ten (10) Days after receipt of a written request.

E. Any copy of the records made available for inspection as copies and furnished upon request to the public or any public agency by the City, the Division of Apprenticeship Standards or the Division of Labor Standards Enforcement shall be marked or

obliterated to prevent disclosure of an individual's name, address and social security number. The name and address of the Contractor awarded the Contract or Subcontractor performing the Contract shall not be marked or obliterated. Any copy of records made available for inspection by, or furnished to, a joint labor-management committee established pursuant to the federal Labor Management Cooperation Act of 1978 (Section 175a of Title 29 of the United States Code) shall be marked or obliterated only to prevent the disclosure of an individual's name and social security number. A joint labor-management committee may maintain an action in a court of competent jurisdiction against an employer who fails to comply with Section 1774. The court may award restitution to an employee for unpaid wages and may award the joint labor-management committee reasonable attorneys' fees and costs incurred in maintaining the action. An action under this subdivision may not be based on the employer's misclassification of the craft of a worker on its certified payroll records. Nothing in this subdivision limits any other available remedies for a violation of this section.

F. The Contractor shall inform the City of the location of the records enumerated under subdivision (A), including the street address, city and county, and shall, within five (5) business days, provide a notice of a change of location and address.

G. The Contractor shall have ten (10) Days in which to comply subsequent to receipt of written notice requesting the records enumerated in subdivision (A). In the event that the Contractor or Subcontractor fails to comply within the ten (10) Day period, the Contractor shall, as a penalty to the State or City, forfeit twenty-five (\$25) Dollars for each calendar day, or portion thereof, for each worker, until strict compliance is effectuated. Upon the request of the Division of Apprenticeship Standards or the Division of Labor Standards Enforcement, these penalties shall be withheld from any progress payment or final payment then due. A contractor

is not subject to a penalty assessment pursuant to this section due to the failure of a Subcontractor to comply with this section.

5-1.07 **SAFETY REQUIREMENTS.** It is the intent of the parties that the City is not an exposing, creating, controlling, or correcting employer under California Labor Code Section 6400. In accordance with generally accepted construction practices and State law, the Contractor shall have the authority and be solely and completely responsible for conditions on the Work Site, including safety of all persons and property during performance of the Work. Moreover, the Contractor shall be the controlling employer and has the authority and responsibility to enforce Work Site safety. The Contractor shall be responsible for conducting daily safety inspections and assuring all hazards and violations are abated. The Contractor is responsible for assuring that all Subcontractors adhere to the minimum Cal/OSHA safety requirements and that each Subcontractor has an effective Cal/OSHA IIPP (Illness and Injury Prevention Program) in place that specifically addresses all potential exposures, such as, but not limited to, fall protection, confined space, and trenching/shoring. These requirements shall apply continuously and not be limited to normal working hours. The Contractor shall be responsible for any delay costs or damages in the event the progress of Work is slowed or stopped due to a safety violation.

The Contractor shall designate a safety officer and have in place a health and safety plan in accordance with the laws of State of California and conduct safety meetings and document them in accordance with the law. The Contractor shall have the safety record available for inspection during working hours and shall submit job site safety meeting reports with each Application for Payment.

Prior to Contractor commencing construction project work on City property, Contractor

shall make available copies of its Health and Safety Plan (HASP) that meets or exceeds applicable Cal/OSHA regulations. The Contractor's HASP shall also meet or exceed the requirements of any applicable City-wide or departmental specific Injury and Illness Prevention Programs (IIPP) and other HASP programs, procedures, and plans. Potentially applicable HASP programs, procedures, and plans include, but are not limited to, the following:

1. Bloodborne Pathogens Exposure Control Plan;
2. Confined Space Entry Procedure;
3. Electrical Safety Program (Lockout/Tagout);
4. Emergency Action Plans (Site Specific);
5. Fire Prevention Plans (Site Specific);
6. Hazardous Waste Operations Emergency Response Plan (or Equivalent);
7. Hazard Communication Program (SDS's and Right-to-Know training);
8. Heat Illness & Prevention Plan;
9. Hearing Conservation Program;
10. Hot Work/Welding Procedure;
11. Job Hazard Analyses/Standard Operating Procedures;
12. Traffic Control & Flagging;
13. Excavation/Dig Safe Procedure;
14. Fall Protection Plan;
15. Personal Protective Equipment Plan;
16. Respirable Crystalline Silica Exposure Control Plan;
17. Respirator Program;
18. Soils Management Plan (for contaminated soils); and

19. Transite (Asbestos) Pipe Work Procedure.

Additionally, Contractor shall be responsible for complying with all City-wide and departmental specific safety requirements as identified in the Supplemental Conditions or presented at a pre-construction meeting.

Contractor shall inform City in advance of the quantity of chemical(s) to be used for the project and the total quantity of chemical(s) that will be brought onto City property. In addition, Contractor shall provide City with one copy of the Safety Data Sheet (SDS) for each chemical expected to be used to complete the project and for each chemical brought to the Work Site, regardless of whether such chemicals are ultimately used for the project.

The services of the Director in conducting construction review of the Contractor's performance is not intended to include review of the adequacy of the Contractor's Work methods, equipment, bracing or scaffolding, or safety measures, in, on, or near the construction site. If a City employee observes a safety violation, the City employee will report the violation to the Contractor who is then responsible for assuring the violation is abated.

The Contractor is hereby informed that Work on this project could be hazardous. The Contractor shall carefully instruct all personnel working in potentially hazardous Work areas as to potential dangers and shall provide such necessary safety equipment and instructions as are necessary to prevent injury to personnel and damage to property. Special care shall be exercised relative to Work underground.

All Work and materials shall be in strict accordance with all applicable State, City, County, and Federal Rules, Regulations, and Codes, and attention is drawn to the requirements of Cal/OSHA. The Contractor shall be solely responsible for compliance with all City, County and State blasting requirements and for any damages caused by its operations.

To ensure compliance with California Labor Code Section 6705, the Contractor shall submit to the City, at least five (5) Days in advance of excavation of any trench five feet (5') or more in depth, Working Drawings to the Director showing the design of shoring, bracing, sloping and other provisions to be made for worker protection from the hazard of caving ground during the excavation of such trench or trenches. If such Working Drawings vary from the shoring system standards established by the Cal/OSHA Construction Safety Orders of the Division of Industrial Safety, the plan shall be prepared and signed by a registered civil or structural engineer in the State of California. This in no way relieves the Contractor from the requirement of maintaining safety in all operations performed by the Contractor or the Contractor's Subcontractors and nothing in this section shall be deemed to allow the use of a shoring, sloping or protective system less effective than that required by the Cal/OSHA Construction Safety Orders of the Division of Industrial Safety Contractor's Working Drawings shall be subject to approval insofar as the details affect the character of the finished Work and for compliance with design requirements applicable to the construction when specified or called for, but details of the design will be left to Contractor who shall be responsible for the successful construction of the Work. The City shall approve Working Drawings before any Work involving such drawings is performed. Approval and/or acceptance by the City or its designated agent only constitutes acknowledgment of the submission and does not constitute review or approval of the designs, design assumptions or criteria, completeness of submissions, applicability to areas of intended use, nor implementation of the plans, which are solely the responsibility of the Contractor and its registered engineer.

The Contractor shall perform its Work as not to expose personnel to, or to discharge into the atmosphere from any source whatever, smoke, dust, asbestos, toxic chemicals or other air

contaminants in violation of the laws, rules, and regulations of the governmental entities having jurisdiction and shall bear full and exclusive responsibility for any release of hazardous or non-hazardous chemicals or substances during the course of the Work. The Contractor shall immediately report any such release to the City. The Contractor shall be solely responsible for all claims and expenses associated with the response to, removal and remediation of the release, including, without limitation, payment of any fines or penalties levied against the City by any agency as a result of such release and shall defend, indemnify, and save and hold harmless the City, its officers, agents, employees, and volunteers from any claims arising from such release. For purposes of this section only, the term “claims” shall include:

1. All notices, orders, directives, administrative or judicial proceedings, fines, penalties, fees, or charges imposed by any governmental agency with jurisdiction; and
2. Any claim, cause of action, or administrative or judicial proceeding brought against the City, its officers, agents, employees, and volunteers for any loss, cost (including reasonable attorneys’ fees), damage or liability, sustained or suffered by any person or entity, including the City.

If the performance of the Work creates any hazardous wastes, those wastes shall be properly disposed of according to federal, state, and local laws, at the expense of the Contractor. The Contractor shall dispose of the wastes under its own EPA Generator Number. In no event shall the City be identified as the generator. The Contractor shall notify the City of any such hazardous wastes and the City reserves the right to a copy of the results of any tests conducted on the wastes, and, at its cost, to perform additional tests or examine those wastes, prior to disposition. The Contractor shall defend, indemnify, and save and hold harmless the City, its

officers, agents, employees, and volunteers from any claims arising from the disposal of the hazardous wastes, regardless of the absence of negligence or other malfeasance by the Contractor. Disposal of all Hazardous Materials must be done in accordance with all laws and regulations. Copies of required regulatory documentation including copies of final manifests shall be supplied to the City.

Contractors or Subcontractors removing one hundred or more square feet (100') of asbestos must be "Certified" in accordance with State law. All Work involving exposure to asbestos and all other hazardous materials shall be performed with protection of personnel in compliance with all applicable regulations and safety requirements including, but not limited to, California Code of Regulations Section 1529, Title 8.

Nothing in these General Conditions is to be construed to permit Work not conforming to governing codes. When Contract Documents differ from governing codes, the Contractor shall furnish and Install the higher standards called for without extra charge.

5-1.08 **SUBSURFACE EXCAVATIONS, NOTIFICATION.** The Contractor shall contact the regional notification center, "Underground Service Alert," and schedule its Work to allow ample time for the center to notify its members and, if necessary, for any member to field locate and mark its facilities. Without limiting the foregoing, the Contractor's attention is directed to Government Code Sections 4216 to 4216.9, and in particular Section 4216.2.

5-1.09 **PUBLIC SAFETY.** The Contractor shall assume all responsibility for public safety during the performance of its Work, and all costs arising therefrom shall be included in the Contract Price. Whenever the Contractor's operations create a condition hazardous to traffic or to the public, it shall furnish, erect and maintain, at its expense, such fences, barricades, lights, signs, and other devices and take such other protective measures as are

necessary to prevent accidents or damage or injury to the public. The Contractor shall establish the pedestrian detours with comparable lighting to the original pedestrian areas. The Contractor shall arrange for such flaggers as are necessary to give adequate warning to traffic or to the public of any dangerous conditions affecting traffic. For Work in a public right-of-way, the Contractor shall comply with the rules and regulations of the State, County, or local agency that owns the right-of-way.

The Contractor shall promptly and fully comply with and carry out, and shall without separate charge therefor to the City, all safety and first aid requirements prescribed by all applicable Federal, State, and local laws and regulations, rules, and orders. The Work shall be done in a safe manner; and the Contractor shall safeguard the safety and health of its employees, Subcontractors, and the people of local communities. The Contractor shall also be reasonable for ensuring that its Subcontractors comply with the provisions of this section.

Upon the failure of the Contractor to comply with any of the requirements of this section, the City shall have the authority, but not the duty, to stop the Work until such failure is remedied. The Contractor shall not be entitled to an adjustment of the Contract Time or an increase in the Contract Price due to any such suspensions.

When required by the Contract Documents, the Contractor shall construct, maintain, and remove detours for use of public traffic, without additional cost to the City, unless separate payment is specified in the Special Provisions.

The failure or refusal of the Contractor to construct and maintain detours at the proper time shall be sufficient cause for closing down the work until such detours are in satisfactory condition for use by public traffic.

Due care shall be exercised to avoid injury to existing improvements or facilities, utility

facilities, adjacent property and trees, shrubs, and other plants that are not to be removed.

Trees, shrubs and other plants that are not to be removed, and pole lines, fences, signs, survey markers and monuments, buildings and structures, conduits, pipe lines, sewer and waterlines, highway facilities, and any other improvements or facilities, under or above ground, that are within or adjacent to the work limit line shall be protected from injury or damage, and the Contractor shall provide and Install suitable safeguards to protect such objects from injury or damage. If such objects are injured or damaged by reason of the Contractor's operations, they shall be replaced or restored at the Contractor's expense. The facilities shall be replaced or restored to a condition as good as when the Contractor entered upon the Work Site, or as good as required by the Contract Documents if any such objects are part of the Work. The City may make or cause to be made such temporary repairs as are necessary to restore to service any damaged facility. The cost of such repairs shall be borne by the Contractor, and the costs may be deducted from any monies due or to become due to the Contractor under the Agreement.

The fact that any underground facilities is not shown on the Contract Drawings shall not relieve the Contractor of its responsibility pursuant to "Utility Facilities" in Section 2-1.12 elsewhere in the Contract Documents. It shall be the Contractor's responsibility, pursuant thereto, to ascertain the location of such underground improvements or facilities, which may be subject to damage by reason of its operations.

Full compensation for furnishing all labor, materials, tools, equipment and incidentals, and for doing all the Work involved in protecting or repairing property as specified in this section, shall be considered as included in the prices paid for the various Contract items of work and no additional compensation will be allowed therefor.

5-1.10 **EMERGENCIES.** In an Emergency affecting the safety of life, the

Work, or adjoining property, the Contractor, without special instructions or authorization from the City, shall act at its discretion to prevent such threatened loss or injury. In such an Emergency, the Contractor may perform such additional work as is reasonably required. Any compensation claimed by the Contractor on account of Work performed to an Emergency shall be determined in accordance with the provisions relating to Force Account payment contained elsewhere in the Contract Documents.

5-1.11 **APPRENTICES.** Attention is directed to Labor Code Sections 1777.5, 1777.6 and 1777.7 and Title 8, California Code of Regulations Section 200 et seq. In accordance with Section 1777.5, the Contractor shall secure the necessary certificates and shall contribute to the apprenticeship fund or funds, as provided therein. The Contractor shall require each Subcontractor who will perform work or labor or render service to the Contractor in or about the construction of the work to fully comply with Sections 1777.5 and 1777.6 of the Labor Code. To insure compliance and complete understanding of the law regarding apprentices, and specifically the required ratio thereunder, each Contractor or Subcontractor should, where some questions exist, contact the Division of Apprenticeship Standards, , or one of its branch offices prior to commencement of Work on the public works Contract. Responsibility for compliance with this section lies with the prime Contractor.

It is State and City policy to encourage the employment and training of apprentices on public works Contracts as may be permitted under local apprenticeship standards.

5-1.12 **FAIR LABOR STANDARDS ACT.** Attention is invited to the fact that the City has been advised by the Wage and Hour Division, U.S. Department of Labor, that Contractors engaged in construction Work are required to meet the provisions of the Fair Labor Standards Act of 1958 and as amended (52 Stat. 1060).

5-1.13 **WORKERS' COMPENSATION.** Pursuant to the requirements of Labor Code Section 1860, the Contractor will be required to secure the payment of workers' compensation to its employees in accordance with the provisions of Labor Code Section 3700.

Prior to the commencement of Work, the Contractor shall sign and file with the Director a certification in the following form:

“I am aware of the provisions of Labor Code Section 3700 which require every employer to be insured against liability for workers' compensation or to undertake self-insurance in accordance with the provisions of that code, and I will comply with such provisions before commencing the performance of the Work of this Contract.”

5-1.14 **AIR POLLUTION CONTROL AND ASBESTOS.** The Contractor shall comply with all air pollution control rules, regulations, ordinances and statutes which apply to any Work performed pursuant to the Contract, including any air pollution control rules, regulations, ordinances and statutes, specified in Government Code Section 11017.

In the absence of any applicable air pollution control rules, regulations, ordinances or statutes governing solvents, all solvents, including but not limited to the solvent portions of paints, thinners, curing compounds, and liquid asphalt used on the project shall comply with the applicable material requirements of the applicable Air Quality Management District. All containers of solvent, paint, thinner, curing compound, or liquid asphalt shall be labeled to indicate that the contents fully comply with said requirements.

Unless otherwise provided in the Supplemental Conditions, material to be disposed of shall not be burned, either inside or outside the Premises.

The Contractor shall also comply with all rules, regulations, statutes and ordinances

regarding asbestos removal and disposal, including but not limited to, 42 U.S.C. Sections 7401, 7412 and 7601, 40 C.F.R. Part 61, Subpart M, and California Code of Regulations Section 1529, Title 8.

If the Contractor discovers that a building to be demolished or renovated contains asbestos containing material, the Contractor shall immediately cease Work and notify the City.

5-1.15 **USE OF PESTICIDES.** The Contractor shall comply with all local, state and federal rules and regulations of the Department of Food and Agriculture, the Department of Health, the Department of Industrial Relations and all other agencies which govern the use of pesticides required in the performance of the Work.

Pesticides shall include but shall not be limited to herbicides, insecticides, fungicides, rodenticides, germicides, nematocides, bactericides, inhibitors, fumigants, defoliant, desiccants, soil sterilants, and repellents.

Any substance or mixture of substances intended for preventing, repelling, mitigating, or destroying weed, insects, diseases, rodents, or nematodes and any substance or mixture of substances intended for use as a plant regulator, defoliant or desiccant shall be considered as pesticide.

5-1.16 **SOUND AND LIGHT CONTROL REQUIREMENTS.** The Contractor shall comply with all local sound control, light control, and noise level rules, regulations and ordinances which apply to any Work performed pursuant to the Contract. Work shall not begin before 7 a.m. nor occur after 7 p.m., unless otherwise permitted by the City.

Each internal combustion engine, used for any purpose on the Work or related to the Work, shall be equipped with a muffler, in good working order, of a type recommended by the manufacturer. No internal combustion engine shall be operated on the project without said

muffler.

5-1.17 **WEIGHT LIMITATIONS.** Unless expressly permitted elsewhere in the Contract Documents, the Contractor shall not operate construction equipment or vehicles of any kind which, laden or unladen, exceed the maximum weight limits set forth in Division 15 of the Vehicle Code over completed or existing base, surfacing, pavement or structures.

5-1.18 **ENVIRONMENTAL CLEARANCES; MITIGATION MONITORING PROGRAMS; AND REGULATORY AGENCY PERMIT REQUIREMENTS.** The Department will obtain all environmental clearances and other authorizations necessary for this project as set forth in the Contract Documents. The Contractor shall comply with the provisions, including giving notices during construction when required, of said authorizations. In the event the obtaining of said authorizations delays completion of all or any portion of the Work, an extension of time determined pursuant to the provisions in Section 6-1.08, “Liquidated Damages,” of these General Conditions will be granted.

Contractor shall comply with: (1) all mitigation identified in the mitigation monitoring program (attached to and adopted as a component of the mitigated negative declaration or Environmental Impact Report) to mitigate impacts to protected natural resources; and (2) all related permit requirements issued by the regulatory agencies authorizing the project. Contractor shall defend, indemnify, and save and hold harmless the City, its officers, agents, employees, and volunteers from any fines, claims, suits, actions or regulatory sanctions of every name, kind and description brought forth, or on account of, damage to protected natural resources from or arising out of Contractor’s negligence or willful misconduct in the performance of this Agreement.

5-1.19 **PERMITS AND LICENSES.** The Contractor acknowledges and agrees that, prior to the submission of its bid for the Work, it fully familiarized itself with the

requirements of all applicable federal, state, county and municipal laws, codes, rules, and regulations, as well as the conditions of any required licenses and permits.

The Contractor shall procure all permits and licenses, including any applicable building permits (except those procured or to be procured by the City which are listed elsewhere in the Contract Documents), in coordination with the Director, pay all charges and fees, and give all notices necessary and incident to the due and lawful prosecution of the Work. Contractor shall be responsible for applying, paying all fees, and coordination for obtaining all permits for completion of the Work. All permits and licenses shall be obtained in sufficient time to prevent delays to the Work. Contractor will apply to the City for reimbursement for such permits costs. Accordingly, Contractor should not include the anticipated costs for permits in its bid, as the necessary permit costs will be reimbursed by the City.

The California Environmental Quality Act (Public Resources Code, Section 21000 to 21177) may be applicable to permits, licenses and other authorizations which the Contractor must obtain from State or local agencies in connection with performing the Work. The Contractor shall comply with the provisions of that Act in obtaining such permits, licenses and other authorizations, and all permits, licenses and other authorizations shall be obtained in sufficient time to prevent delays to the Work.

The Contractor shall maintain the applicable Contractor's license as identified in the Notice to Contractors and City business license for the duration of the Work.

5-1.20 **WATER POLLUTION.** The Contractor shall comply with all water pollution control rules, regulations, ordinances and statutes which apply to any Work performed pursuant to the Contract, including any water pollution control rules, regulations, and statutes, specified by the most current State of California NPDES General Permit for Stormwater

Discharges Associated with Construction Activity.

The Contractor shall take all necessary precaution to protect streams, vernal pools, ponds, reservoirs, and lakes from pollution with fuels, oils, bitumen, calcium chloride, and other harmful materials as consistent with the law. Also, the Contractor shall conduct and schedule operations so as to avoid discharging pollutants, such as but not limited to: sediment and silt to the storm drain system. The storm drain system consists of all facilities that are designed to convey stormwater to the Waters of the State as defined in the California Water Code. The storm drain system includes, but is not limited to, all streets, gutters, drain inlets, roadside ditches, streams, vernal pools, ponds, and lakes. Care shall be exercised to preserve roadside vegetation beyond the limits of construction.

5-1.21 **PROTECTION AND USE OF PROPERTY.** The Contractor shall be responsible for and provide and maintain all proper temporary walkways, covered walkways, barriers, roads, guards, railings, lights, warning signs, and take precaution at all times to avoid injury or damage to any person or any property, and upon completion of the Work, or at other times as directed, restore Premises and adjacent property to a proper condition. In the event of such injury or damage, Contractor shall report such injury and damage to City within forty-eight (48) hours of occurrence.

The Contractor shall protect adjoining property and nearby buildings, including City buildings, City roads, and public streets or roads, from dust, dirt, debris, or the nuisance arising out of the Contractor's operations or storage practices, and, if ordered by the Director, the Contractor shall provide and Install suitable safeguards, approved by the Director, to protect such objects from damage. If such objects are damaged by reason of the Contractor's operations, they shall be replaced or restored at the Contractor's expense.

If the Contractor damages any buildings, roads, utilities, or other property which belong to the City, or any Department or agency thereof, then the Director, at his or her option, may retain from the money due under the Contract an amount sufficient to insure repair of the damage.

The Director may make or cause to be made such temporary repairs as are necessary to restore to service any such damaged facility. The cost of such repairs shall be borne by the Contractor and may be deducted from any moneys due or to become due the Contractor under the Contract.

5-1.22 **RESPONSIBILITY FOR DAMAGE AND INDEMNIFICATION.**

The City of Roseville, its officers, agents, employees, and volunteers, including but not limited to the Director and his or her designee, shall not be answerable or accountable in any manner: for any loss or damage that may happen to the Work or any part thereof; for any loss or damage to any of the materials or other things used or employed in performing the Work; for injury to or death of any person, either workers or the public; or for damage to property from any cause which might have been prevented by the Contractor, its workers, or anyone employed by the Contractor or the Contractor's Subcontractors.

The Contractor shall be responsible for any liability imposed by law and for injuries to, or death of, any person including, but not limited to, workers and the public, or damage to property resulting from defects or obstructions, or from any cause whatsoever during the progress of the Work or at any time before its completion and final Acceptance.

To the fullest extent allowed by law, the Contractor shall defend (through counsel acceptable to the City), indemnify, and save and hold harmless the City, and its respective officers, agents, Subcontractors, employees, and volunteers, and the successors and assigns of

any of them, (hereinafter referred to as “Indemnitees”) from and against all claims, demands, liability, suits, actions, costs or expenses for any and all loss or damage, including but not limited to, personal injury, property damage, or economic loss, arising out of or resulting from allegations of (1) Contractor’s use of the City’s property or any activities or Work performed hereunder by the Contractor; (2) the Contractor’s performance of the Work under the Agreement; or (3) the Contractor’s breach of any provision of the Agreement. The duty of the Contractor to indemnify and save harmless includes the duties to defend as set forth in Civil Code Section 2778. The only exception to these provisions is that the Contractor’s obligations under this section will not apply to the extent that the claims, demands, liability, suits, actions, costs or expenses are caused by Indemnitees’ active negligence, willful misconduct, criminal acts, or for defects in design furnished by the Indemnitees, misconduct, criminal acts, or for defects in design furnished by the Indemnitees.

The Contractor waives any and all rights to any type of express or implied indemnity against the City, its officers, agents, employees, or volunteers.

The Contractor’s responsibility for such defense and indemnity obligations shall survive the termination or completion of this Contract for the full period of time allowed by law. The defense and indemnity obligations of this Contract are undertaken in addition to, and shall not in any way be limited by, the insurance obligations contained in this Contract. The parties intend that the defense and indemnity obligations in this Contract shall be broadly construed.

Any person, firm or corporation that Contractor authorizes to Work on the City’s property including Subcontractors, shall be deemed to be an agent of the Contractor for purposes herein, shall be subject to all the applicable terms herein, and shall be within the scope of the Contractor’s indemnity obligation described herein.

In addition to any remedy authorized by law, so much of the money due the Contractor under and by virtue of the Contract as shall be considered necessary by the Department may be retained by the City until disposition has been made of such suits or claims for damages.

The retention of money due the Contractor shall be subject to the following:

A. The City will give the Contractor thirty (30) Days' notice of its intention to retain funds from any partial payment which may become due to the Contractor prior to Acceptance of the Contract. Retention of funds from any payment made after Acceptance of the Contract may be made without such prior notice to the Contractor.

B. No retention of additional amounts out of partial payments will be made if the amount to be retained does not exceed the amount being withheld from partial payments pursuant to Section 7-1.07, "Progress Payments," of these General Conditions.

C. If the City has retained funds and it is subsequently determined that the City is not entitled to be indemnified and saved harmless by the Contractor in connection with matter for which such retention was made, the Department shall be liable for interest on the amount retained at the legal rate of interest for the period of such retention.

5-1.23 **INSURANCE COVERAGE.**

A. **Evidence of Maintenance Required.** The Contractor shall, at its expense, procure and at all times maintain in full force and effect at a minimum the insurance required by this section on all of its operations; and the Contractor shall not allow any Subcontractor to commence work until similar insurance required of the Subcontractor has been obtained and filed. An original Certificate of Insurance, and copies of all required endorsements, all in a form approved by the Risk Manager, evidencing all required coverage or policies shall be filed after the award of the bid and prior to approval of the Contract by the City Council. Contractor shall

provide ten (10) days prior written notice to the City of any reduction of coverage limits or cancellation of the coverage or policies shall be given to the City of Roseville as Certificate holder.

B. Qualifying Insurers. With the exception of the State Compensation Insurance Fund, all required insurance policies shall be issued by companies acceptable to the City and licensed to do business in the State of California and who hold a current policy holders alphabetic and financial size category rating of not less than AVII according to the most recent issue of Best's Insurance Reports.

C. Insurance Required.

1. Commercial General Liability (CGL): Insurance Services Office Form CG 00 01 covering CGL on an “occurrence” basis, including products and completed operations with limits of no less than Two Million Dollars (\$2,000,000) per occurrence for bodily injury, personal injury and property damage for projects under One Million Dollars (\$1,000,000) and limits of no less than Five Million Dollars (\$5,000,000) per occurrence for bodily injury, personal injury and property damage for projects over One Million Dollars (\$1,000,000). If a general aggregate limit applies, either the aggregate limit shall apply separately to this project or the general aggregate limit shall be twice the required occurrence limit.

The Commercial General Liability insurance shall include the following, copies of which shall be provided:

a. Inclusion of the City of Roseville, and its officers, agents, employees, and volunteers, as additional insureds (except for workers’ compensation) as respects services or operations under the Contract. The additional insured endorsement for the general liability policy shall be at least as broad as the ISO CG 2010 10 01 combined with ISO CGL

Endorsement CG 2037 10 01. Any other endorsement must be approved in writing by the City. Endorsements must include coverage for on-going and completed operations, which coverage shall be maintained for four (4) years following completion of the Project. Endorsements shall cover the City of Roseville, its officers, agents, employees, and volunteers.

b. The insurance shall provide coverage for claims by one insured against another insured and the policies shall not contain any cross-suits exclusions, cross-liability exclusions, or insured versus insured exclusions. The policies shall not contain any classification exclusions purporting to deny coverage for any work to be performed by Contractor or any of its Subcontractors.

c. Stipulation that the insurance is primary and noncontributory, as evidenced by a separate endorsement (CG 20 01 04 13 or an equivalent) or section of the policy, and that neither the City nor its insurers will be called upon to contribute to a loss.

d. Such insurance shall specifically cover the contractual liability of the Contractor.

e. Any available insurance proceeds in excess of the specified minimum insurance coverage requirements and limits shall be available to the additional insureds. Furthermore, the requirements for coverage and limits shall be: (1) the minimum coverage and limits specified in this Agreement; or (2) the full coverage and maximum limits of any insurance proceeds available to the named insureds, whichever is greater.

f. Waiver of subrogation endorsement.

g. The Contractor shall furnish a certificate for the period covered.

2. Automobile Liability: Insurance Services Office Form Number CA 0001 covering Code 1 (any auto), or if Contractor has no owned autos, Code 8 (hired) and Code 9

(non-owned), with limits of no less than One Million Dollars (\$1,000,000) per accident for bodily injury and property damage.

3. Workers' Compensation: In accordance with the provisions of the California Labor Code, Contractor is required to be insured against liability for Workers' Compensation or to undertake self-insurance. Statutory Workers' Compensation and Employers' Liability of at least One Million Dollars (\$1,000,000) shall cover all Contractors staff while performing any work incidental to the performance of this Agreement.

4. Professional Liability: Professional Liability (Errors and Omission) Insurance appropriate to Contractor's profession, with a limit of liability not less than One Million Dollars (\$1,000,000) per occurrence or claim and Two Million Dollars (\$2,000,000) aggregate to cover all design and engineering services rendered by Contractor pursuant to the Agreement. Coverage must commence from the first day that Contractor or any of its Subcontractors provided any design or engineering services in connection with the Project.

5. Builder's Risk/Course of Construction Insurance (If Required by Risk Management): The Contractor shall be responsible for all loss, damage or destruction whatsoever to the work called for by this Contract until the approval of a Notice of Completion or acceptance of the Work if no Notice of Completion is to be recorded.

The Contractor shall secure "All Risk" type of builder's Risk Insurance of the type covering one hundred percent (100%) of the value of the work performed under this Contract (the value is presumed to be the Contract amount unless otherwise stated in Supplemental Conditions) and all materials, equipment, or other items to be incorporated therein while the same are located at the construction site, a bonded warehouse, or its place of manufacture. At any time, the policy shall cover the value of the work completed. The policy shall cover hazards

including the losses due to fire, explosion, hail, rain, lightning, flood (separate insurance as needed), vandalism, malicious mischief, wind, collapse, aircraft, and smoke.

The policies providing such insurance shall name the City as a loss payee as its respective interests may appear, and certified copies of such policies shall be filed with the City. The maximum deductible allowable under the Builder's All Risk policy shall be five percent (5%) of the Contract amount.

Builder's Risk Insurance is not required for coverage of losses in excess of five percent (5%) of the Contract amount for damages resulting from earthquake in excess of a magnitude of 3.5 on the Richter scale, or tidal waves. Coverage in the amount of five percent (5%) of the Contract amount for such losses is required.

6. Pollution Coverage: Contractor shall procure pollution liability coverage or other insurance covering claims for bodily injury or property damage arising out of the abatement, removal, storage, transportation, or other exposure to hazardous materials or pollutants, in limits not less than Two Million Dollars (\$2,000,000). Contractor shall add the City and all parties required to be indemnified by Contractor as additional insured on all pollution liability policies.

7. Higher Coverage Limits: If Contractor maintains higher coverage limits than the amounts shown above, then the City requires and shall be entitled to coverage for the higher coverage limits maintained by Contractor. Any available insurance proceeds in excess of the specified minimum limits of insurance and coverage shall be available to the City.

8. Claims Made Coverage: Liability insurance coverage may not be written on a "claims made" or modified occurrence basis. The Certificate of Insurance must clearly provide that the coverage is on an "occurrence" basis.

5-1.24 **OTHER INSURANCE PROVISIONS.**

A. The requirements of the Standard Specifications as to types and limits of insurance coverage to be maintained by the Contractor, and any approval of insurance by the City, are not intended to, and shall not in any manner limit or qualify the liabilities and obligations otherwise assumed by the Contractor pursuant to the Contract, including, but not limited to, the provisions concerning indemnification, nor preclude the City from taking any other action available to it under any other provision of the Contract or law.

B. The City acknowledges that some insurance requirements contained in these Standard Specifications may be fulfilled by self-insurance on the part of the Contractor. However, this shall not in any way limit liabilities assumed by Contractor under the Contract. Any self-insurance must be approved in writing by the City, in its sole discretion and shall not reduce the limits of liability. Any deductibles or self-insured retentions (“SIR”) must be declared on the certificate of insurance and approved by City in writing. Policies containing any SIR provision shall provide or be endorsed to provide that the SIR may be satisfied by either the named insured or City. City reserves the right to obtain a full certified copy of any insurance policy and endorsements. The failure to exercise this right shall not constitute a waiver of such right.

C. The Contractor agrees to include in its contracts with all subcontractors the same requirements and provisions of this Contract, including the indemnity and insurance requirements, to the extent they apply to the scope of the subcontractor’s work. Furthermore, the Contractor shall require its subcontractors to agree to be bound to the Contractor and the City in the same manner and to the same extent as the Contractor is bound to the City under this Contract. Additionally, the Contractor shall obligate its subcontractors to comply with these

same provisions with respect to any tertiary subcontractor, regardless of tier. A copy of the City's indemnity and insurance provisions will be furnished to the subcontractor or tertiary subcontractor upon request. Alternatively, the Contractor may insure subcontractor(s) under its own policy.

D. The City, its officers, agents, employees, and volunteers are to be covered as insureds with respect to liability arising out of automobiles owned, leased, hired or borrowed by or on behalf of the Contractor; and with respect to liability arising out of work or operations performed by or on behalf of the Contractor including materials, parts or equipment furnished in connection with such work or operations. Coverage shall not extend to any indemnity coverage for the active negligence of the additional insured in any case where an agreement to indemnify the additional insured would be invalid under California Insurance Code Section 11580.04.

E. The limits of insurance required in this Contract may be satisfied by a combination of primary and excess insurance. Any excess insurance shall contain or be endorsed to contain a provision that such coverage shall also apply on a primary and noncontributory basis for the benefit of the City (if agreed to in a written contract) before the City's own insurance shall be called upon to protect it as a named insured.

F. The insurance procured by Contractor shall be subject to the approval of the City, but any acceptance of insurance certificates by the City shall in no way limit or relieve Contractor of its duties and responsibilities under the Agreement.

G. Contractor shall be responsible for all premiums, deductibles, and self-insured retention applicable to the insurance it is required to procure under the Contract. All deductibles or self-insured retentions over five hundred thousand dollars (\$500,000) must be approved by the City, in writing. Contractor shall be responsible for all deductibles, self-insured

retention payments, and/or increased premiums incurred if the City's policies of insurance are forced to cover damages or respond to claims for which Contractor or its Subcontractors were obligated to provide insurance under the Contract.

H. Failure of the City to enforce in a timely manner any of the requirements of these insurance provisions shall not act as a waiver to enforcement of any of these provisions at a later date.

I. Contractor's indemnity obligations shall not be limited by these insurance provisions and shall survive the expiration of the Contract and the insurance provisions of the Contract shall likewise not be limited by the indemnity provisions of the Contract.

J. THE CITY RESERVES THE RIGHT TO WITHHOLD ANY PROGRESS PAYMENTS TO THE CONTRACTOR IN THE EVENT OF NONCOMPLIANCE WITH ANY INSURANCE REQUIREMENTS.

5-1.25 **THIRD PARTY BENEFICIARY.** No provisions in the Contract Documents shall in any way inure to the benefit any third party (including the public at large or any member thereof) so as to constitute such person a third party beneficiary of the Contract, or of any term or condition or other provision of the Contract or otherwise give rise to any cause of action in any person not a party to the Agreement, except as expressly provided elsewhere in the Contract Documents.

5-1.26 **COORDINATION AND ACCESS.** The Contractor acknowledges that the City may award, or has already awarded, other construction contracts for additional work or may perform additional work with its own forces and that such work may affect the Work under this Agreement. Additionally, the Contractor acknowledges that the State and other public and private agencies may be granted a right-of-entry by the City for the purpose of constructing

facilities within and adjacent to the Work Site. It is the obligation of the Contractor to coordinate its Work with the work of others working within or adjacent to the City's property.

During performance of its Work, the Contractor shall not have exclusive access to or use of the work areas. The City may also require that certain facilities and areas be used concurrently by the Contractor and by other contractors working in the area. When two (2) or more contractors are employed on related or adjacent City work, each shall conduct its operations in such a manner as not to cause any unnecessary delay or hindrance to the other. Each contractor shall be responsible to the other for all damage to any work, to persons or property caused to the other by its operations, and for loss caused the other due to any unnecessary delays or failure to finish the work within the time specified for completion.

If any party of the Contractor's Work depends on the work of any other contractor and/or the City for proper execution and/or results, the Contractor shall promptly notify the City of any discrepancies and/or defects in said other work that would render its work unsuitable for proper execution and/or results prior to proceeding with the Contractor's own Work. If it becomes necessary, the City will resolve coordination and access problems.

The Contractor and its representative in charge of the Work shall familiarize themselves with the City's property and Work Site, and adjacent surroundings in the vicinity of said Work, and any private or public operations on adjoining properties.

5-1.27 **OCCUPANCY BY THE DEPARTMENT PRIOR TO**

ACCEPTANCE. The City may at any time notify the Contractor in writing that it intends to take Beneficial Occupancy of any portion of the Work even though the Work may not be substantially complete. Unless the reason for the City's taking Beneficial Occupancy is that the Contractor has not completed the Work (or portions thereof) in accordance with the Contract

Time, the City's Beneficial Occupancy shall relieve the Contractor from its responsibility for maintenance, loss or damage to that portion of the Work for which the City has taken Beneficial Occupancy other than that resulting from the Contractor's act or omission, negligence, willful misconduct or breach of warranty.

Should the Work (or portion thereof) not be completed in accordance with the Construction Schedule within the Contract Time (as adjusted under the terms of the Contract Documents), the City shall have the right, but not the obligation, to take Beneficial Occupancy of the Work. In such event, the Contractor shall not be entitled to any additional compensation on account of said occupancy by the City, nor shall the Contractor be relieved of any of its responsibilities under the Contract Documents, including, without limitation, Contractor's obligation to complete the Work in accordance with the Construction Schedule.

Beneficial Occupancy shall not be deemed an Acceptance by the City either of the Work or of any portion thereof, nor will it relieve the Contractor of full responsibility for correcting defective Work or materials found at any time before the formal written Acceptance of the entire Contract by the Director or during the full warranty period after such Acceptance, as provided in Section 7-1.12, "Warranty," of these General Conditions.

The City's Beneficial Occupancy shall not relieve the Contractor of its responsibility to maintain all insurance and bonds required under the Contract Documents until the entire project is accepted by the City.

5-1.28 **RIGHT TO OPERATE UNSATISFACTORY FACILITIES AND EQUIPMENT.** If, after Installation, the operation or use of the facilities or equipment to be furnished under this Contract proves to be unsatisfactory to the Director, the City shall have the right to operate and use such facilities or equipment until they can, without damage to the City,

be taken out of service for correction or replacement. Such period of use of the defective facilities or equipment, pending correction or replacement, shall in no way decrease the warranty period required for the acceptable corrected or replaced facilities or equipment.

5-1.29 **CONTRACTOR'S RESPONSIBILITY FOR THE WORK.** Except as otherwise provided herein, the Contractor shall have the charge and care of the Work and shall bear the risk of injury or damage to any part of the Work by the action of the elements or from any other cause whether arising from the execution or from the nonexecution of the Work until the Acceptance of the Contract by the Director. The Contractor shall rebuild, repair, restore, and make good all injuries or damages to any portion of the Work occasioned by any cause before its completion and Acceptance, and shall bear the expense thereof. In case of suspension of Work from any cause whatever, the Contractor shall be responsible for the Work and it shall also be responsible for all materials, and shall properly store them if necessary, and shall provide suitable drainage and erect temporary structures where necessary.

The Contractor will be relieved of responsibility for any injury or damage to the Work caused by the following:

- A. An earthquake in excess of a magnitude of 3.5 on the Richter Scale or a tidal wave, when the effect of such has been proclaimed a disaster or state of emergency by the Governor of the State of California or by the President of the United States, or was of such magnitude at the site of the Work as to have been sufficient to have caused a proclamation of disaster or state of emergency, had it occurred in a populated area.

- B. Occupancy and use by the Department or the public prior to the completion of the entire project.

- C. Acts of the Federal Government or the public enemy.

5-1.30 **RESPONSIBILITY FOR UTILITIES.** The Contractor shall be responsible at its own cost for any and all Work, expense or special precautions caused or required by the existence or proximity of utilities encountered in performing the Work, including without limitation, repair of any or all damage and all hand or exploratory excavation required. The Contractor is cautioned that such utilities may include communication cables or electrical cables which may be high voltage, and when working or excavating in the vicinity of such cables, or the ducts enclosing such cables, the Contractor shall undertake at its own cost any special precautions required. Suitable warning signs, barricades, and safety devices shall be erected as necessary or required.

However, if during the course of the Work the Contractor encounters utility Installations which are not shown or indicated in the Contract Documents or which are found in a location substantially different from that shown, and such utilities are not reasonably apparent from visual examination, then the Contractor shall promptly notify the Director in writing. Where necessary for the Work of the Contract, the Director shall issue a written order to the Contractor to make such adjustments, rearrangement, repair, removal, alteration, or special handling of such utility, including repair of the damaged utility. The Contractor shall perform the Work described in such written order, and compensation therefor will be made in accordance with Section 3 of these General Conditions relating to changes in the Work. Except for the items of cost specified in said Section 3, the Contractor shall receive no compensation for any other cost, damage, delay, interference, or hindrance to him or her due to the presence of such utility. If the Contractor fails to give the notice specified above and thereafter acts without instructions for the Director, then the Contractor shall be liable for any or subsequent to discovery thereof, and the Contractor shall repair and make good such damage at its own cost.

The precise location of underground facilities can only be determined by careful probing or hand digging in compliance with Article 6 of the Cal/OSHA Construction Safety Orders which states in part:

“Prior to opening an excavation, effort shall be made to determine whether underground installations, i.e., sewer, water, fuel, electric lines, etc., will be encountered, and if so, where such underground installations are located. When the excavation approaches the approximate location of such an installation, the exact location shall be determined by careful probing or hand digging, and, when it is uncovered, adequate protection shall be provided for the existing installation.”

The location of known existing utilities and pipelines are shown on the Contract Drawings in their approximate locations. Some of the locations include multiple conduits. The Contractor shall exercise care in avoiding damage to those facilities which are to remain in service subsequent to the construction of the particular new facility involved and the Contractor will be held responsible for any repairs if damaged. The Contractor shall also exercise care in maintaining those pipes and facilities required for continuing operation of the existing facilities until such time as they can be abandoned. There is no guarantee that all utilities or obstructions are shown on the Contract Drawings or that the locations indicated are accurate.

The Contractor shall exercise extreme caution in working in the area adjacent to the existing pipelines and utility services. It is essential that all the existing facilities be maintained in service. Construction of the connections between the existing facilities and the new facilities shall be at times and during periods acceptable to the City. The Contractor shall advise the Director in writing of its proposed Construction Schedule for these connections at least forty-eight (48) hours in advance.

The Contractor shall uncover all piping and conduits, to a point one foot (1') below the pipe, where crossings, interferences, or connections are shown on the Contract Drawings, prior to trenching or excavating for any pipe or structures, to determine actual elevations. New pipelines shall be laid to such grade as to clear all existing facilities which are to remain in service. If the Contractor does not expose all required utilities, it shall not be entitled to additional compensation for Work necessary to avoid interferences nor for repair to damaged utilities. Excavations around underground electrical ducts and conduits shall be performed using extreme caution to prevent injury or damage to workers and to the electrical ducts or conduits.

5-1.31 **PROPERTY RIGHTS IN MATERIALS.** Nothing in the Contract shall be construed as vesting in the Contractor any right of property in the materials used after they have been attached or affixed to the Work or soil or after partial payment has been made as provided in Section 7-1.07, "Progress Payments," of these General Conditions for material delivered on the ground or stored subject to or under the control of the City and unused. All such material shall become the property of the City upon being so attached or affixed or upon payment for materials delivered on the ground or stored subject to or under the control of the City and unused, as provided in said Section 7-1.07.

5-1.32 **COURT ORDERED DELAY.** If, pursuant to court order, the Department temporarily suspends performance of all or any portion of the Work, an extension of time determined pursuant to the provisions in Section 6-1.08, "Liquidated Damages," of these General Conditions will be granted.

5-1.33 **NO PERSONAL LIABILITY.** Neither the Director, nor any other officer or authorized employee of the City, shall be personally responsible for any liability arising under or by virtue of the Contract.

5-1.34 **RIGHTS IN LAND AND IMPROVEMENTS.** The Contractor shall make no arrangements with any person or entity to permit occupancy or use of any land, structure or building within the limits of the Work, for any purpose whatsoever, either with or without compensation, in conflict with any agreement between the City and any third party owner, former owner, or tenant of such land, structure or buildings. The Contractor shall not occupy City-owned property outside the limit of the Work shown on the Contract Drawings unless it obtains prior approval.

5-1.35 **ANTITRUST CLAIMS.** The Contractor's attention is directed to the following provision of Public Contract Code Section 7103.5(b), which is applicable to the Contractor and its Subcontractors:

“ In entering into a public works contract or a subcontract to supply goods, services, or materials pursuant to a public works contract, the contractor or subcontractor offers and agrees to assign to the awarding body all rights, title, and interest in and to all causes of action it may have under Section 4 of the Clayton Act (15 U.S.C. Sec. 15) or under the Cartwright Act (Chapter 2 [commencing with Section 16700] of Part 2 of Division 7 of the Business and Professions Code), arising from purchases of goods, services, or materials pursuant to the public works contract or the subcontract. This assignment shall be made and become effective at the time the awarding body tenders final payment to the contractor, without further acknowledgement by the parties.”

5-1.36 **RIGHTS TO DRAWINGS, TECHNICAL DATA PATENTS.** Shop

Drawings and Working Drawings submitted to the City by the Contractor, Subcontractor or any lower tier Subcontractor pursuant to the Agreement, are the property of the City and the City may use, and disclose in any manner and for any purpose, Shop Drawings and Working Drawings delivered under the Contract.

Technical Data including manuals or instructional materials, computer or microprocessor software which are delivered or submitted to the City by the Contractor, Subcontractor, or any lower tier Subcontract pursuant to the Contract are the property of the City, and the City may use or disclose same in any manner and for any purpose.

The Contractor shall assume all costs arising from the use of patented materials, equipment, devices, or processes used on or incorporated in the Work, and shall defend, indemnify and save and hold harmless the City, and its duly authorized representatives, from all suits at law, or in equity, and actions of every nature for, or on account of the use of any patented materials, equipment, devices or processes. In case some materials, equipment, devices or processes are held to constitute an infringement and their use enjoined, the Contractor, at its expense, shall:

1. Secure for the City the right to continue using said materials, equipment, devices or processes by suspension of the injunction or by procuring a license or licenses; or
2. Replace such materials, equipment, devices, processes; or
3. Modify them so that they become non-infringing or remove the enjoined materials, equipment, devices or processes and refund the sums paid therefor without prejudice to any other rights of the City.

5-1.37 **PAYMENT OF TAXES.** Contractor shall pay all taxes and duties applicable to and assessable against any Work, equipment, materials, services, processes, and

operations incidental to or involved in the Agreement, including but not limited to, retail sales and use, transportation, export, import, business, and special taxes. The Contractor is responsible for ascertaining and acquainting itself with such taxes and making all necessary arrangements to pay them. The Contractor will maintain records that are auditable records, and these records shall be subject to the City's review to verify that Contractor's tax payments are current at all times.

The Contract Price paid for the Work shall include full compensation for all taxes which the Contractor is required to pay, whether imposed by Federal, State or local government, including, without being limited to, Federal excise tax. No tax exemption certificate nor any document designed to exempt the Contractor from payment of any tax will be furnished to the Contractor by the Department, as to any tax on labor, services, materials, transportation, or any other items furnished pursuant to the Contract.

The Contractor shall withhold and pay any and all sales and use taxes, withholding taxes, whether Federal, State, or local, Social Security taxes, State Unemployment Insurance charges and all other taxes which are now or hereafter may be required to be paid or withheld under any laws.

5-1.38 **GRATUITIES AND CONFLICT OF INTEREST.** The Contractor shall not offer or provide gratuities in the form of gifts, entertainment, loans, meals, rewards, and/or services to representatives of the City, including but not limited to, officers, employees, agents, Engineering Service Consultants, Consulting Engineers and Architects, Inspectors and/or Testing Agencies retained by the City. If it is found that the Contractor has violated this provision, the Contract may be subject to termination for default as defined elsewhere in these General Conditions.

During the term of the Contract and until the final payment has been made to the Contractor, the Contractor shall not employ or compensate in any manner whatsoever, the City's officers, employees and authorized representatives, agents, and any Engineering Service Consultants, Consulting Engineers and Architects, Inspectors, and/or Testing Agencies retained by the City. Any exception to the employment or compensation to any of the above named parties must be made in writing by the City. If the Contractor offers or provides employment or compensation to those named above during the term of the Contract, the Contract may be subject to termination for default.

5-1.39 **COOPERATION.** Should construction be under way by City forces or other forces or by other Contractors within or adjacent to the limits of the Work or should Work of any other nature be under way by such forces within or adjacent to said limits, the Contractor shall cooperate with all such forces to the end that any delay, interference or hindrance to their Work will be avoided. The right is reserved to perform other or additional Work at or near the site at any time, by the use of such forces.

5-1.40 **DIGGING TRENCHES OR OTHER EXCAVATIONS.** In the event any work involves digging trenches or other excavations that extend deeper than four feet (4') below the surface, City and Contractor shall comply with the following:

A. The Contractor shall promptly, and before the following conditions are disturbed, notify City in writing of any:

1. Material that the Contractor believes may be material that is hazardous waste, as defined in Section 25117 of the Health and Safety Code, that is required to be removed to a Class I, Class II, or Class III disposal site in accordance with provisions of existing law.

2. Subsurface or latent physical conditions at the site differing from those made available to Contractor for inspection as provided in the project proposal.

3. Unknown physical conditions at the site of any unusual nature, different materially from those ordinarily encountered and generally recognized as inherent in Work of the character provided for in the Contract.

B. The City shall promptly investigate the conditions, and if it finds that the conditions do materially so differ, or do involve hazardous waste, and cause a decrease or increase in the Contractor's cost of, or the time required for, performance of any part of the Work shall issue a Change Order under the procedures described in the Contract.

C. In the event that a dispute arises between the City and the Contractor whether the conditions materially differ, or involve hazardous waste, or cause a decrease or increase in the Contractor's cost of, or time required for, performance of any part of the Work, the Contractor shall not be excused from any scheduled completion date provided for by the Contract, but shall proceed with all work to be performed under the Contract. The Contractor shall retain any and all rights provided either by contract or by law which pertain to the resolution of disputes and protests between the contracting parties. However, no claim of the Contractor under this clause shall be allowed unless the Contractor has given the notice required by this Section. No claim by the Contractor for an equitable adjustment hereunder shall be allowed if asserted after final payment under this Contract.

5-1.41 **CONTRACTOR REGISTRATION.** No contractor or subcontractor may work on a public works project unless registered with the Department of Industrial Relations pursuant to Labor Code section 1725.5. During the performance of this Contract, the Contractor and its subcontractors shall have a continuing legal obligation to maintain current

registration with the Department of Industrial Relations. The Contractor is hereby notified that this project is subject to compliance monitoring and enforcement by the Department of Industrial Relations.

5-1.42 **CITY OF ROSEVILLE ENCROACHMENT PERMITS AND RIGHTS-OF-WAY.** The Contractor need not obtain a separate encroachment permit from the City prior to construction within street rights-of-way or other City rights-of-way. Execution of the Contract by the City shall be deemed an encroachment permit for work required by the Contract within rights-of-way. All work shall conform to the rules and regulations of encroachment permits and shall be subject to the inspection and approval of the Director and City Engineer.

To the extent indicated in the Contract Drawings, the City will provide the rights-of-way over private lands or the site to enable the Contractor to perform its work. The Contractor shall be solely responsible for securing any additional rights-of-way desired by the Contractor. The City will not be a party to nor assume any liability for any separate agreements reached between the Contractor and any third parties with respect to these additional rights-of-way. The Contractor shall procure evidence that agreements are in place with said third parties before the Contractor uses those areas covered by the agreements. Any damage to such private lands caused by the Contractor's operations shall be the sole responsibility of the Contractor.

SECTION 6

PROSECUTION AND PROGRESS

6-1.01 **SUBLETTING AND SUBCONTRACTING.** The Contractor shall be responsible for all Work performed under the Contract. The Contractor shall give its personal attention to the fulfillment of the Contract and shall keep the Work under its control. Nothing in the Contract Documents shall create any contractual relationship between the City and any Subcontractor. The Contractor is fully responsible to the City for the acts and omissions of its Subcontractors of any tier. When any Subcontractor fails to prosecute a portion of the Work in a manner satisfactory to the Director, that Subcontractor shall not again be employed on the Work. Although the sections of the Contract may be arranged according to various trades, or general grouping of the Work, the Contractor is not obligated to sublet the Work in such manner. The Director will not arbitrate disputes among Subcontractors or between Contractor and one or more Subcontractors concerning responsibility for performing any part of the Work.

The on-site production of materials produced by other than the Contractor's own forces shall be considered as subcontracted. The erection, establishment or reopening of on-site plants for production of materials and the operation thereof in the production of materials for use on the Work shall conform to the requirements relating to labor set forth in the Contract Documents.

The Contractor shall also be responsible for coordinating the Work performed by Subcontractors and Suppliers.

The Contractor shall not substitute any person as Subcontractor in place of a Subcontractor listed on its bid proposal without the written approval of the Director. Substitutions must be in accordance with the provisions of the "Subletting and Subcontracting

Fair Practices Act” beginning with Public Contract Code Section 4100. Violations of this Act by the Contractor may subject it to penalties which may include cancellation of Contract, Assessment of ten percent (10%) of the Subcontractor's bid, and disciplinary action by the Contractors State License Board.

The Contractor shall pay any Subcontractors approved by the City for work that has been satisfactorily performed no later than seven (7) Days from the date of Contractor’s receipt of progress payments by the City. Within seven (7) Days after receipt from the City of funds attributable to work performed by a Subcontractor, Contractor shall release any retainage payments withheld to the Subcontractor. In the event Contractor does not make progress payments or release retention to Subcontractors in accordance with the time period specified herein, Contractor may be subject to prompt payment penalties per statute.

6-1.02 **ASSIGNMENT.** The performance of this Contract may not be assigned, except upon the written consent of the City Council of the City of Roseville. Consent will not be given to any proposed assignment which would relieve the original Contractor or its surety of their responsibilities under the Contract nor will the City consent to any assignment of a part of the Work under the Contract.

The Contractor may assign moneys due or to become due to it under the Contract and such assignment will be recognized by the City, if given proper notice thereof, to the extent permitted by law, but any assignment of moneys shall be subject to all proper set-offs in favor of the City and to all deductions provided for in the Contract and particularly all money withheld, whether assigned or not, shall be subject to being used by the City for the completion of the Work in the event that the Contractor should be in default therein.

6-1.03 **BEGINNING OF WORK.** After the execution of the Contract by both

parties, the City will issue the Notice to Proceed upon its determination that it is appropriate for the Contract Time to commence.

The Contractor shall begin Work within fifteen (15) Days after receiving the Notice to Proceed from the Director, subject to the requirements stated elsewhere in the Contract Documents regarding, among other things, the submittal of Baseline Schedule, and shall diligently prosecute the same to completion within the time limit provided in the Supplemental Conditions. Contractor shall also achieve any and all Contract milestones as described elsewhere in the Contract Documents.

The Contractor shall notify the Director, in writing, of its intent to begin Work at least seventy-two (72) hours before Work is begun. The notice shall be delivered to the Director and shall specify the date the Contractor intends to start. If the project has more than one (1) location of Work, a separate notice shall be given for each location.

The Contractor is not authorized to perform any Work until it has received a Notice to Proceed from the City. Should the Contractor begin Work in advance of receiving notice that the Contract has been approved as above provided, any Work performed by it in advance of the said date of approval shall be considered as having been done by the Contractor at its own risk and as a volunteer unless said Contract is so approved thereafter.

6-1.04 **PROGRESS SCHEDULE.**

A. Preliminary Progress Schedule. The Contractor shall submit to the Director, within twenty (20) Days after date of the Notice to Proceed, a Preliminary Progress Schedule covering the Contractor's activities over the first three (3) months of operation in detail and the remainder of the project in summary. The Preliminary Progress Schedule shall schedule the project within the Contract Time for completion of the Work, and shall be subject to

favorable review by the Director.

B. CPM Schedule. The Contractor shall submit an acceptable Critical Path Method (CPM) Schedule to the Director within thirty (30) Days after the receipt of the Notice to Proceed. Subsequent revisions to said schedule shall be submitted as set forth hereinafter. The requirement for the CPM schedule is included to allow for adequate planning and execution of the Work, to determine the critical nature of delays, and to assist the Director in appraising the reasonableness of the proposed schedule and evaluating progress of the Work. The CPM schedule submitted under this Section shall utilize a CPM format, either the precedence or arrow diagramming method. The definitions of CPM terms and functions shall be as provided in the Associated General Contractors of America book *CPM in Construction, A Manual for General Contractors*, or a favorably reviewed alternative publication or reference. No progress payment will be made prior to submission and acceptance of the CPM Schedule.

1. The CPM schedule system shall consist of diagrams and accompanying mathematical analyses. The diagrams shall show elements of the project in detail and an entire project summary. Diagrams shall show the order and interdependence of activities and sequence in which the Work is to be accomplished as planned by the Contractor. The basic concept of a network analysis diagram shall be followed to show how the start of a given activity is dependent on the completion of preceding activities and its completion restricts the start of following activities. Detailed network activities shall include, in addition to construction activities, the submittal and favorable review of samples of material and Shop Drawings, the procurement of critical materials and equipment, fabrication of special material and equipment, and their Installation and testing. All activities of the City and the Director that affect progress and required Contract dates for completion of all or parts of the Work shall be shown. The

selection and number of activities shall be subject to favorable review by the Director. Summary networks shall be time scaled. Durations shall be in Days and shall not exceed fifteen (15) Days, except for submittal and delivery items. Where the duration of continuous Work exceeds fifteen (15) Days, Work items in the Construction Schedule shall be subdivided by location, approximate stationing or other sub-element of the Work.

The graphic network diagram shall include for each activity, the description, activity number, the estimated duration in Days, and all activity relationship lines. The network diagram shall be drawn for the early start of activities. All significant Submittals shall be scheduled along with manual Submittals and training on all large or critical pieces of equipment. If the precedence technique is utilized, the schedule project shall include a calendar in Work Days, a network report sorted by early start and a logic table report sorted by preceding Work item. If the arrow technique is utilized, the schedule report shall include a calendar in Work Days, a network report sorted by early start, a network report sorted by I-J numbers, and a network sorted by slack time and I-J numbers.

2. The critical path shall be shown on all reports and on the graphic network diagram. The activities which constitute the critical path shall be identified.

3. The mathematical analysis of the network diagram shall include a tabulation of each activity. The following information shall be furnished as a minimum for each activity:

- (a) preceding and following event numbers
- (b) activity description and number
- (c) estimated duration of activities
- (d) earliest start date (by calendar date)

- (e) earliest finish date (by calendar date)
- (f) actual start date (by calendar date)
- (g) actual finish date (by calendar date)
- (h) latest start date (by calendar date)
- (i) latest finish date (by calendar date)
- (j) slack or float
- (k) percentage of activity completed

4. The program shall be capable of accepting revised completion dates as modified by approved time adjustments and recomputations of all tabulation dates and float accordingly.

5. Submission and review of the system shall be as follows:

(a) The complete network analysis system, consisting of the detailed network mathematical analysis and network diagrams, shall be submitted within thirty (30) Days after receipt of the Notice to Proceed.

(b) The Contractor shall participate in a review and evaluation of the proposed network diagrams and analysis by the Director. Any revisions necessary as a result of this review shall be resubmitted for review by the Director within ten (10) Days. When completed, the favorably reviewed schedule shall then be the schedule to be used by the Contractor for planning, organizing and directing the Work and for reporting progress. If the Contractor thereafter desires to make significant changes in its method of operating and scheduling, the Contractor shall notify the Director in writing stating the reasons for the change.

(c) The Contractor shall submit at monthly intervals a report of the actual construction progress. Each monthly report shall cover a period of approximately thirty

(30) Days ending around the 20th of each month. The monthly reports shall be submitted within ten (10) Days of the end of the reporting period.

(1) If the project is proceeding on schedule, the monthly update report may consist of a marked-up copy of the graphical network diagram. This submittal shall clearly indicate the status of any minor shifts in sequence or schedule and the estimated completion date or percent complete of all activities currently in progress. The Contract completion date shall also be indicated. The Contractor shall submit a narrative report relating to status of construction, the schedule, and factors which may affect the remainder of the schedule. The report shall show the activities or portions of activities completed during the reporting period. The report shall state the percentage of the Work actually completed and scheduled as of the report date and the progress along the critical path in terms of Days ahead or behind the allowable dates.

(2) If, in the opinion of the Director, the project is behind schedule, the monthly report shall include a revised network diagram and/or mathematical analysis showing the Contractor's proposed revised schedule. An analysis of the effect that the delay has on progress along other paths shall also be included in the report. The Contractor shall also submit a narrative report with each updated analysis which shall include but not to be limited to a description of current and anticipated problem areas, delaying factors and their impact, and an explanation of corrective actions taken or proposed.

(3) Periodic report shall be submitted in sufficient copies to cover Contractor needs plus five (5) copies and an available electronic copy to be retained by the Director.

6. To the extent that the favorably reviewed initial Construction Schedule, or revisions thereto, indicate anything not jointly agreed upon, it shall be deemed to be not favorably reviewed by the Director. Any omission of Work from the detailed schedule, otherwise required for Contract compliance, will not excuse the Contractor from completing such Work within any applicable completion date. The CPM schedule shall be generated by computer methods.

C. Schedule Review. Once each month, on a date mutually agreed upon, but no later than seven (7) business days after the monthly schedule progress report date, a Work Site meeting will be held to review the Construction Schedule and job progress. The Contractor shall also attend weekly meetings scheduled by the Director to review the progress of the Work in the preceding week and in the subsequent week, coordinate the Work with public agencies or other Contractors as required, and allow the Director to plan his or her activities for testing, inspection, etc.

D. Schedule Revisions. The conditions under which the Director will require revisions of the Construction Schedule include the following:

1. When delay in completion of any Work item or sequence of Work items results in an estimated extension of project completion by either twenty (20) business days or by ten percent (10%) of the remaining duration of time to complete the Contract, whichever is less.

2. When delays in Submittals or deliveries make replanning or rescheduling of the Work necessary.

3. When the schedule does not represent actual prosecution and progress of the Work.

4. When any change to the sequence of activities, the completion date for major portions of the Work, or when changes occur which affect the critical path.

5. When Contract Amendments or a Change Order necessitates schedule revision, the Contractor shall submit a schedule analysis of all Change Order Work with its proposal.

E. Cash Flow Projection. A cash flow projection shall be submitted with the Construction Schedule. This cash flow projection shall be revised and resubmitted when revisions of the Construction Schedule will result in changes to the projected cash flow.

F. Schedules showing project completion dates earlier than specified in the Supplemental Conditions will be rejected unless justification can be provided for early completion.

6-1.05 **SCHEDULE OF VALUES.** Prior to preparation of the first estimate for a progress payment, the Contractor shall submit for favorable review by the Director a detailed Schedule of Values or cost breakdown of the Work under each bid item awarded. The breakdown will then become the basis for partial payment determination. Elements of Work shall be grouped by structure, pipeline, system, etc. Within each grouping, Work should be itemized by readily measurable quantities of Work complete in place. For example, concrete should be in units of cubic yards including form Work and reinforcing steel. Move-on costs, bond and insurance costs, and Overhead costs shall not be considered an item of cost for this purpose but shall be prorated over items of Work. In the event the Schedule of Values is not favorable reviewed by the Director, another Schedule of Values shall be submitted that is mutually acceptable to the Contractor and the Director.

6-1.06 **CITY'S RIGHT TO STOP WORK.** The Director shall have the

authority to order the Contractor, in writing, to suspend the Work wholly or in part, for such period as the Director may deem necessary due to the failure on the part of the Contractor to correct Work that is not in accordance with the requirements of the Contract Documents or if Contractor persistently fails to carry out Work in accordance with the Contract Documents.

The Contractor shall immediately comply with the written order of the Director to suspend the Work wholly or in part. The suspended Work shall be resumed when conditions are favorable and methods are corrected, as ordered or approved in writing by the Director.

Any stoppage of work under this section shall be at the Contractor's sole expense, and the Contractor shall have no claim against the City based on the Contractor's failure to perform the Work in accordance with the Contract Documents.

In addition to the City's right to stop Work, the City may order the Contractor to submit to the City at no additional cost to the City, additional information concerning Contractor's planned Work if the Contractor fails to promptly correct Work that is not in accordance with the requirements of the Contract Documents or persistently fails to carry out Work in accordance with the Contract Documents. The additional information ordered by the City may include, but is not limited to, preparation of Submittals or Working Drawings not otherwise required to be submitted under the Contract Documents.

In the event the City discovers that the Contractor has created an unsafe condition the City may arrange for other work forces to remedy the condition. Such remedial work shall be at the sole discretion of the City. If this action is required, the City may unilaterally terminate Work under the Contract, and will pay only for the quantities of Work actually performed, less the cost of the City's remedial Work. In the event that Work is not halted, the Contractor must take immediate steps to correct the situation. There will be no extra payment for Work required

to correct unsafe conditions.

The right of the City to suspend the Work shall not give rise to a duty on the part of the City to exercise this right for the benefit of the Contractor or any other person or entity. This right shall be in addition to and not in restriction or derogation of the City's other rights under the Contract Documents.

In the event of a suspension of Work under any of the conditions set forth in this Section 6-1.06, such suspension of Work shall not relieve the Contractor of its legal responsibilities as set forth in these General Conditions.

6-1.07 **TIME OF COMPLETION.** The Contractor shall complete the entire Work, including Installation, repairs, startup, troubleshooting, painting, and touchup, training, submittal or record drawings, and manuals, cleanup, demobilization, and all other Work within the number of Days set forth in the Supplemental Conditions. The time for completion includes an allowance for working time lost due to normal inclement weather.

Extensions of time may be allowed for unusual inclement weather under the provisions hereinafter described. Unusual inclement weather is weather which adversely affects "controlling" operations or the critical path of construction and which meets one of the following criteria:

A. For the particular calendar month in question, the number of individual Days with rainfall exceeding 0.10 inches exceeds the average number of such Days for that month over the immediately preceding five (5) years of record by at least three (3) Days.

B. For the particular calendar month in question, the total cumulative rainfall for that month exceeds the average cumulative rainfall for that month over the immediately preceding five (5) years of record by at least two inches (2").

Rainfall shall be measured at a publicly operated, maintained, and reported station in reasonable proximity to the construction site. A claim for delay shall indicate the period of rainfall which is claimed as “unusual,” the specific dates during which the unusual rainfall and subsequent wet soil conditions prevented Work, and the specific critical path tasks adversely affected by such unusual weather. A claim for delay due to unusual inclement weather shall be filed within ten (10) Days of the apparent end of the unusual inclement rainfall period, whether or not the monthly totals are available at that time. The burden of proof that weather meets the criteria for unusual weather shall be solely the responsibility of the Contractor.

It is the responsibility of the Contractor to order materials required for the Work properly and promptly on a Notice to Proceed. If evidence presented demonstrates that, in spite of the Contractor's efforts, government-established priorities controls delay material deliveries, suitable extension of time will be made.

If performance of extra Work ordered by the City or failure of the City to provide the necessary site for Installation affects construction tasks which are “controlling” or which are on the “critical path” of the Construction Schedule, suitable extensions of time will be made.

The Contractor shall not be entitled to a time extension for delays in activities on non-critical paths of the favorably reviewed schedule unless the duration of the excusable delay exceeds the total float of the activities being delayed. If the duration of an excusable delay does exceed the total float of the activities affected by the delay, the Contractor shall be entitled to an extension equal to the difference.

C. Determination that a day is a non-working day by reason of inclement weather or conditions resulting immediately therefrom, shall be made by the Director.

6-1.08 **LIQUIDATED DAMAGES.** It is agreed by the parties to the Contract

that in case all the Work called for under the Contract in all parts and requirements is not completed within the number of Days as set forth in the Supplemental Conditions, damage will be sustained by the City and that it is and will be impracticable and extremely difficult to ascertain and determine the actual damage which the City will sustain in the event of and by reason of such delay; and it is therefore agreed that the Contractor will pay to the City, the monetary amount indicated in the Supplemental Conditions in dollars (U.S.) per day for each and every calendar day of delay in completing the Work in excess of the number of Days prescribed and the number of additional calendar days, if any, authorized by Contract Change Order; and the Contractor agrees to pay said Liquidated Damages herein provided for, and further agrees that the City may deduct the amount thereof from any moneys due or that may become due the Contractor under the Contract.

It is further agreed that in case the Work is not finished and completed in all parts and requirements within the number of Days specified, the City shall have the right to increase the number of Days or not, as it may deem best to serve the interest of the City, and if it decides to increase the said number of Days, it shall further have the right to charge to the Contractor, its heirs, assigns or sureties and to deduct from the final payment for the Work all of any part, as it may deem proper, of the actual cost of engineering, inspection, superintendence, and other Overhead expenses which are directly chargeable to the Contract, and which accrue during the period of such extension, except that cost of preparation of final statement shall not be included in such charges.

6-1.09 **DELAYS AND EXTENSIONS TO THE WORK.** The Contractor must complete all Work within the time specified in the Agreement. The Contractor will be granted an extension of time and will not be assessed with liquidated damages or the cost of engineering

and inspection for any delay in substantially completing the Work (or parts thereof) beyond the time set forth in the Agreement, provided that such delay was caused by unforeseeable causes beyond the control and without the fault or negligence of the Contractor. Examples of such causes include acts of public enemy, fire, floods, abnormal weather (as described below), earthquakes, epidemics, quarantine restrictions, strikes, labor disputes and freight embargoes, fire, changes made pursuant to the provisions of “Changes in the Work” under Section 3 of these General Conditions or acts or neglect of the City not contemplated by the Contract Documents. In all cases, any extension of time is conditioned on the following:

1. That the cause is not due to the fault or negligence of the Contractor, and the Contractor has taken reasonable precautions to prevent and minimize the effects thereof; and
2. That the Contractor notifies the Director in writing within three (3) Days from the beginning of such delay specifying the nature of the delay and the measures that have been or will be taken to prevent or minimize the delay. Failure to submit written notice within this time period shall constitute an absolute waiver of any claim for a time extension.

No extension of time will be granted for a delay caused by a shortage of materials, unless the Contractor furnishes to the City documentary proof that it has diligently made every effort to obtain such materials from all known sources within reasonable reach of the work and further proof, as acceptable to the Director, that the inability to obtain such materials when originally planned did in fact cause a delay in Final Completion of the entire Work which could not be compensated for by revising the sequence of the Contractor’s operations. Only the physical shortage of material will be considered as a cause for extension of time, and no consideration

will be given to any claim that material could not be obtained at a reasonable, practical or economical cost or price, unless it is shown to the satisfaction of the City that such material could have been obtained only at exorbitant prices entirely out of line with current rates, taking into account the quantities involved and the usual practices in obtaining such quantities.

No extension of time will be granted for a delay caused by Contractor's staff turnovers, understaffing or insufficient quantity of qualified staff able to perform the necessary work.

The term "shortage of materials," as used in this section, shall apply only to materials, articles, parts or equipment which are standard items and shall not apply to materials, parts, articles or equipment which are processed, made, constructed, fabricated or manufactured to meet the specific requirements of the Contract Documents.

No extensions of time will be granted for delays that have no measureable impact on the completion of the Work (or parts thereof) under the Contract Documents. When extensions of time are granted, they will be limited to the period equivalent to the actual number of Days lost on the critical path or controlling operations of the Construction Schedule, taking into account the extent to which that delay could be decreased by reasonable mitigation measures by the Contractor. All requests for extensions of time must be supported with a critical path analysis showing the critical path and impacts to it. Contractor's failure to submit this analysis will be sufficient cause for denial of any request for a time extension.

Within a reasonable period of time after the Contractor submits the notice and information required by this section, the City will determine whether an extension of time is justified and, if so, the number of days for the extension.

Abnormal weather may be a valid basis for a time extension under the Agreement. "Abnormal Weather" occurs when the number of days of rain above 0.5 inches in a 24 hour

period exceeds the average for such rainfall in a particular month as determined by the National Weather Service. The Contractor will only be entitled to, at most, a time extension for the number of days of rain exceeding the average for that month in the locale where the Work is to be performed. If delays are caused by the Contractor or those for whom the Contractor is responsible, the Contractor will only be entitled to, at most, a time extension for the number of rain days exceeding the average for the month when the Work should have been performed.

In addition, before a time extension may be granted for abnormal weather, the Contractor must establish that the rain either significantly impacted at least sixty percent (60%) of the planned work of the controlling operations for a particular day or prohibited at least five (5) hours of work on the controlling operations planned for that day. Contractor shall employ reasonably methods to mitigate the impact of abnormal weather (i.e., dewatering, protection of site, etc.) The occurrence of rain during non-work hours or having minimal impact to work on the controlling operation shall not constitute a day of abnormal weather.

In the event that the project experiences favorable weather for a particular month (e.g., the number of actual rain days in a month less than that indicated above for allowable rain days per months), the additional float resulting from such favorable weather shall accrue to the project.

Any Contractor claim for damages or additional compensation based on delay shall be limited to only those circumstances where the Contractor has fulfilled each of the following three (3) requirements:

1. Contractor has established its entitlement to a time extension pursuant to the provisions described above regarding delay and extensions to the Work.
2. The delay was caused solely by the City's issuance of changes made pursuant to the

provisions of “Changes in the Work” under Section 3 of these General Conditions or by acts or neglect of the City.

3. The delay was unreasonable under the circumstances and not within the contemplation of the parties.

It is expressly understood and agreed that delays caused by the City will be non-compensable when there are concurrent delays caused by the Contractor. Also, the Contractor shall have no entitlement to additional compensation for any delay where there have been concurrent delays caused by non-compensable delays, including, but not limited to, fire, floods, earthquakes, epidemics, quarantine restrictions, strikes, labor disputes, and freight embargoes.

Contractor’s damages and/or additional compensation for delays will consist solely of the extended costs of maintaining the Contractor’s Work Site presence. The Contractor will not be entitled to any extended home office overhead.

Compensation for idle time of equipment will be determined in the same manner as determinations are made for equipment used in the performance of extra work paid for on a Force Account basis with the following exceptions:

1. The time for which compensation will be paid will be the actual normal working hours during which such delay conditions exists, but in no case will exceed eight (8) hours in any one day.
2. The days for which compensation will be paid will be each calendar day of the work week (defined elsewhere in the Contract Documents) and Legal Holidays, during the existence of such delay, except that when rental of the equipment is paid for under the provisions in Section 3-1.06C, “Force Account Payment – Equipment,” of these General Conditions, no payment will be made for delays in accordance with the

provisions of this section.

Actual loss shall be understood to include no items of expense other than idle time of personnel, cost of extra moving of equipment, and cost of longer hauls. Compensation for idle time of equipment will be determined as provided in this section and compensation for idle time of personnel will be determined pursuant to Section 3-1.06A, "Force Account Payment – Labor," of these General Conditions. No markup will be added in either case for Overhead and profit. The cost of extra moving of equipment and the cost of longer hauls will be paid for as extra work as provided pursuant to "Changes to the Work" elsewhere in the Contract Documents.

6-1.10 **TERMINATION.**

6-1.10A **TERMINATION OF AGREEMENT – CONVENIENCE OF CITY.** The Department reserves the right to terminate the Contract at any time and for any reason if the Director determines that to do so would be in the best interest of the City. Any termination which is not based on the circumstances set forth in Section 6.1-10B below shall be effected by delivery to the Contractor of a Notice of Termination specifying the extent to which performance of Work under the Contract is terminated, and the date upon which such termination becomes effective.

Upon the Contractor's receipt of a written Notice of Termination for convenience, the Contractor shall cease Work as to those portions of the project so terminated and shall undertake the steps outlined in Section 6-1.10B below.

1. Acceptance of the Contract as hereinafter specified shall not relieve the Contractor of responsibility for damage to materials except as follows:
 - a. The Contractor's responsibility for damage to materials for which partial payment has been made as provided in Section 7-1.07, "Progress

Payments,” of these General Conditions and for materials furnished by the City for use in the Work and unused shall terminate when the Director certifies that such materials have been stored in the manner and at the locations he or she has directed.

- b. The Contractor's responsibility for damage to materials purchased by the City subsequent to the issuance of the notice that the Contract is to be terminated shall terminate when title and delivery of such materials has been taken by the City.
- c. When the Director determines that the Contractor has completed the Work under the Contract directed to be completed prior to termination and such other Work as may have been ordered to secure the project for termination, the Contractor will recommend that the City formally accept the Work, and immediately upon and after such Acceptance by the City, the Contractor will not be required to perform any further Work thereon and shall be relieved of its contractual responsibilities for injury to persons or damage to property which occurs after the formal Acceptance of the project by the City.

2. The total compensation to be paid to the Contractor shall be determined by the Director on the basis of the following:

- a. The reasonable cost to the Contractor, without profit, for all Work performed under the Contract, including mobilization, demobilization and Work done to secure the project for termination. Reasonable cost will include a reasonable allowance for project Overhead and general

administrative Overhead not to exceed a total of seven percent (7%) of Direct Costs of such Work.

- b. A reasonable allowance for profit on the cost of the Work performed as determined under subsection (a), provided the Contractor establishes to the satisfaction of the Director that it is reasonably probable that it would have made a profit had the Contract be completed and provided further, that the profit allowed shall in no event exceed four percent (4%) of said cost.
- c. The reasonable cost to the Contractor of handling material returned to the vendor, delivered to the Department or otherwise disposed of as directed by the Director.
- d. A reasonable allowance for the Contractor's administrative costs in determining the amount payable due to termination of the Contract.

All records of the Contractor and the Contractor's Subcontractors, necessary to determine compensation in accordance with this Section, shall be open to inspection or audit by representatives of the Department at all times after issuance of the notice that the Contract is to be terminated and for a period of three (3) years, and such records shall be retained for that period.

After Acceptance of the Work by the Director, the Director may make payments on the basis of interim estimates pending issuance of the Final Statement, when in his or her opinion the amount thus paid, together with all amounts previously paid or allowed, will not result in total compensation in excess of that to which the Contractor will be entitled. All payments, including payment upon the Final Statement, shall be subject to deduction for prior payments and amounts, if any, to be kept or retained under the provisions of the Contract.

In the event that the City terminates this Contract under Section 6-1.10B below and it is determined for any reason that there was not sufficient cause to do so, the City's termination automatically will convert to a termination for convenience under this section and the terms and conditions outlined in this section automatically will be applied to effectuate the Contract termination. Thus, damages to which a Contractor may be entitled as a result of an improper default termination will be limited to the amounts provided for in this section.

The provisions of this section shall be included in all subcontracts.

6-1.10B **TERMINATION OF AGREEMENT - FOR CAUSE.** An

“Event of Default” as referred to in this section shall occur if the Contractor:

1. Fails to maintain progress of the Work in accordance with the requirements of the Contract Documents; or
2. Fails to prosecute the Work or any of its components in accordance with the Contract Documents; or
3. Persistently or repeatedly fails or refuses to supply sufficient properly skilled workers or proper material to permit the performance of the Work in accordance with the Contract Documents; or
4. Fails to make prompt payment to Subcontractors or Suppliers in accordance with the respective agreements between the Contractor and the Subcontractor and Contractor and Supplier; or
5. Fails to comply with applicable laws, ordinances or rules, regulations or orders of a public authority having jurisdiction over the Work; or
6. Abandons, assigns or sublets the Contract without approval of the City; or
7. Becomes bankrupt or is subject to appointment of a receiver on behalf of the

Contractor; or

8. Otherwise is guilty of a substantial breach of a provision of the Contract Documents.

Upon the City's reasonable belief that there has been an Event of Default by the Contractor, the City may elect to give the Contractor written notice thereof. The Contractor thereafter shall cure the default as soon as possible and in no event after ten (10) Days from the Contractor's receipt of the City's written notice.

If the Contractor does not timely cure its default, the City may, without waiver of any of its other rights and remedies, elect to terminate the Contract, or portion thereof.

Upon the City's election to terminate the Contract, or portion thereof, the City shall have the right to complete the Work, or portion involved, by whatever means and methods it deems expedient, including the hiring of others on such terms as the City deems advisable. The City shall have the right to take possession of the Contractor's materials, plant, tools, equipment and property of any kind provided by or on behalf of the Contractor for the purpose of the Work, or a portion of them, without being responsible to the Contractor for wear and tear. The Contractor shall have no rights in such property during its use by the City. The City shall not be required to obtain the lowest prices for completing the Work or a portion of it but shall make such expenditures as, in the City's sole judgment, best accomplish such completion.

The expense of completing such Work or portion thereof, together with a reasonable charge for engineering, managerial and administrative services, as certified by the City, shall be charged to the Contractor, and the expense so charged shall be deducted by the City out of such monies as may be due or may at any time thereafter become due to the Contractor. In case such expense is more than the sum which otherwise would have been payable to the Contractor under the Agreement, then the Contractor or its surety or sureties shall promptly pay the amount of

such excess so due. When the City terminates the Contract under this section, the Contractor shall not be entitled to receive any further payments until the Work is completed and there has been a final settlement of costs of completing the Work covered by such notice of default.

The City will issue to the Contractor a written notice specifying that the Contract, or portion thereof, is terminated. Upon receipt of said written notice and, except as otherwise directed in writing by the City, the Contractor shall:

1. Stop all Work under the Contract; or if partial termination, stop Work relating to the terminated portion of the Agreement;
2. Perform Work the City deems necessary to secure the Work Site for termination including measures to leave the Work Site in a safe condition;
3. Remove equipment from the site of Work, as specified by the City;
4. Take such action as is reasonably necessary to protect materials from damage;
5. Notify all Subcontractors and Suppliers that the Contract or portion thereof is being terminated and that their contracts or orders are not to be further performed unless otherwise authorized in writing by the City;
6. Provide the City with an inventory list of all materials previously produced, purchased or ordered from Suppliers for use in the Work and not yet used in the Work, including its storage location, and such other information as the City may request;
7. Dispose of materials not used in the Work as directed by the Director. It shall be the Contractor's responsibility to provide the City (a) with good title to all materials purchased by the City hereunder, including materials for which partial payment has been made by the City and (b) with bills of sale or other documents of title for such

materials;

8. Subject to the prior written approval of the City, settle all outstanding liabilities and all claims arising out of Subcontractors or orders for materials terminated hereunder. To the extent directed by the City, the Contractor shall assign to the City all rights, title and interests of the Contractor under subcontracts or orders for materials terminated hereunder. The City shall be at liberty to negotiate with and engage any Subcontractors who had contracted with the Contractor for the Work;
9. Furnish the City with the documentation required to be furnished by the Contractor under the provisions of the Contract Documents, including, on projects as to which Federal funds are involved, all documentation required under the Federal requirements included in the Agreement; and
10. Take such other actions as the City may direct.

If only a portion of the Work has been terminated, the Contractor shall perform the remainder of the Work in conformity with the Contract Documents and in such a manner as not to interfere with the City or others in their performance and completion of the portion of the Work which was terminated.

The City may recover from the Contractor the amount of any loss or damage, including consequential damages, suffered or incurred as a result of the Contractor's default.

SECTION 7

ACCEPTANCE AND PAYMENT

7-1.01 **ACCEPTANCE.** When the Contractor believes that the entire Work is fully and finally completed, including the satisfactory completion of inspections, tests, and documentation specified in the Contract Documents and completion of all punch list and clean-up items, the Contractor shall submit to the City a written request for final Acceptance within fifteen (15) Days thereafter, specifying that the Work is fully and finally completed and the date on which it was completed. Within thirty (30) Days after receipt of the request for final Acceptance, the City will inspect the Work and will either:

1. Reject the request for final Acceptance, specifying the defective and/or uncompleted portions of the Work; or
2. Notify the Contractor that the Work will be accepted by Resolution of the City Council of the City of Roseville, and a Notice of Completion will be caused to be recorded by the City Clerk; or
3. Notify the Contractor that the Work has been accepted by the City but no Notice of Completion will be recorded.

If the City rejects the request for final Acceptance, the Contractor shall promptly remedy the defective and/or uncompleted portions of the Work. Thereafter, the Contractor shall again submit a written request for final Acceptance of the Work, specifying a new date based on the date the defective and/or uncompleted portions of the Work were corrected. Thereafter, the foregoing procedure shall apply successively until the City has verified that the Work is fully and finally completed and accepted the Work by Resolution of the City Council or by written

notification from the Director. Immediately upon such Acceptance, the Contractor shall be relieved of the duty of maintaining the Work as a whole.

All warranties commence upon final Acceptance of the Work. The City's final Acceptance of the Work shall not be construed as an acceptance by the City of any latent defects discovered with regard to the Contractor's work. Furthermore, Contractor's obligations under Section 5-1.22 "Responsibility for Damage and Indemnification" shall still remain applicable after the City's grant of final Acceptance of the Work.

Prior to final Acceptance, the Contractor shall submit to the City the Record Documents and Operation and Maintenance Manuals as specified in the Contract Documents.

7-1.02 **SCOPE OF PAYMENT.** The Contractor shall accept the compensation provided in the Contract as full payment for furnishing all labor, materials, tools, equipment, and incidentals necessary to the completed Work and for performing all Work contemplated and embraced under the Contract; also for loss or damage arising from the nature of the Work, or from the action of the elements, or from any unforeseen difficulties which may be encountered during the prosecution of the Work until the Acceptance by the Director and for all risks of every description connected with the prosecution of the Work, also for all expenses incurred in consequence of the suspension or discontinuance of the Work as provided in the Contract; and for completing the Work according to the Contract. Neither the payment of any estimate nor of any retained percentage shall relieve the Contractor of any obligation to make good any defective Work or material.

No compensation will be made in any case for loss of anticipated profits.

7-1.03 **NOTICE OF POTENTIAL CLAIM.** The Contractor shall not be entitled to the payment of any additional compensation for any act or failure to act by the City,

including failure or refusal to issue a Change Order, or for the happening of any event, thing, occurrence or other cause unless the Contractor has given the City due written Notice of Potential Claim as hereinafter specified, provided, however, that compliance with this Section 7-1.03 shall not be a prerequisite as to matters within the scope of the notice provisions in Section 6-1.07, "Time of Completion," or the notice provisions in Section 6-1.08, "Liquidated Damages," of these General Conditions, nor to any claim which is based on differences in measurement or errors of computation as to correct quantities.

The written Notice of Potential Claim shall set forth the reasons for which the Contractor believes additional compensation will or may be due, the nature of the costs involved, and, insofar as possible, the amount of the potential claim. The said Notice as above required must have been given to the Director prior to the time that the Contractor shall have performed the Work giving rise to the potential claim for additional compensation, if based on an act or failure to act by the Director, or in all other cases within seven (7) Days after the happening of the event, thing, occurrence or other cause giving rise to the potential claim.

If the Notice of Potential Claim does not include complete information about the claim or the parties do not execute a Contract Change Order in connection with the Notice of Potential Claim, Contractor shall submit complete information about its claim for additional compensation and/or extension of time for performance within fifteen (15) Days after such work is performed. Failure to provide written notice of claim prior to undertaking such work or failure to timely submit a complete and specific information about the claim for additional compensation and/or extension of the time for performance shall be deemed a waiver and abandonment of such claim.

If there is a dispute over any claim, the Contractor shall continue to Work during the dispute resolution process in a diligent and timely manner as directed by the City, and shall be

governed by all applicable provision of the Agreement.

The Contractor shall maintain cost records of all Work that is the basis of any dispute. On a daily basis, Contractor shall submit to City completed daily forms, the format of which will be acceptable to the City, with respect to the Contractor's costs of performing the disputed work. These daily forms shall itemize all of Contractor's costs in performing the disputed work, including, but not limited to, all costs relating to materials, labor and equipment with respect to the disputed work. These daily forms shall provide names or identification and classification of affected workers, the hourly rate of pay and hours worked, and also the size, type, and identification number of equipment and hours operated. Said daily work forms shall be duly signed and verified by the Contractor or its authorized representative. The City's receipt of the Contractors' daily forms shall not constitute an approval of the Contractor's claim. Contractor's failure to submit the daily forms on a daily basis shall constitute a waiver of the Contractor's right to claim any additional compensation for the disputed work.

Each Contractor claim shall include full and complete information concerning the Claim. Contractor shall provide a clear, concise recital of the basis, upon which the claim is asserted, including a designation of the provisions of the Contract Documents upon which the claim is based. Contractor shall also include a statement as to the amount of time and/or compensation sought pursuant to the claim; if Contractor's claim arises from an ongoing occurrence, Contractor shall so state in its claim, including a description of the specific Work activities affected by the claim. All costs, expenses or damages and extensions of time claimed shall be described in reasonable detail under the circumstances together with complete supporting documentation.

The City will review any timely Notice of Potential Claim and supporting information

submitted by Contractor. In conducting this review, the City shall have the right to require the Contractor to submit such additional or supporting documents, data and other information as the City may require.

If an agreement can be reached which resolves the Contractor's claim, the parties will execute a Contract Change Order to document the resolution of the claim. If the parties cannot reach agreement with respect to the Contractor's claim, the Contractor shall still be obligated to comply with the claim identification provisions identified in these General Conditions, including but not limited to Section 7-1.04.

It is the intention of this Section 7-1.03 that differences between the parties arising under and by virtue of the Contract be brought to the attention of the Director at the earliest possible time in order that such matters may be settled, if possible, or other appropriate action promptly taken. The Contractor hereby agrees that it shall have no right to additional compensation for any Claim that may be based on any such act, failure to act, event, thing or occurrence for which no timely written Notice of Potential Claim as herein required was filed.

7-1.04 **CLAIMS.** Contractor must submit all Claims, for which it has previously submitted a Notice of Potential Claim, prior to Acceptance of the Work. Each such Claim must be sent to the City by registered mail or certified mail with return receipt requested and must contain reasonable documentation to support the Claim.

Upon receipt of a Claim, the City shall conduct a reasonable review of the Claim and, within a period not to exceed forty-five (45) Days, or such further time as mutually agreed upon or necessary pursuant to Public Contract Code Section 9204, the City shall provide the Contractor a written statement identifying what portion of the Claim is disputed and what portion is undisputed. If the City does not respond to a Claim from the Contractor within the time

specified herein, such Claim shall be deemed rejected in its entirety.

Any payment due on an undisputed portion of the Claim shall be processed and made within sixty (60) Days after the City issues its written statement.

If the Contractor disputes the City's written response, or if the City does not respond within the time specified herein, the Contractor may demand in writing an informal conference to meet and confer for settlement of the issues in dispute. Upon receipt of a demand in writing sent by registered mail or certified mail, return receipt requested, the City shall schedule a meet and confer conference within thirty (30) Days for settlement of the dispute.

Within ten (10) business days following the conclusion of the meet and confer conference, if the claim or any portion of the claim remains in dispute, the City shall provide the Contractor a written statement identifying the portion of the Claim that remains in dispute and the portion that is undisputed. Any payment due on an undisputed portion of the Claim shall be processed and made within sixty (60) Days after the City issues its written statement. Any disputed portion of the Claim, as identified by the Contractor in writing, shall be submitted to nonbinding mediation, with the City and the Contractor sharing the associated costs equally. The City and the Contractor shall mutually agree to a mediator within ten (10) business days after the disputed portion of the Claim has been identified in writing. If the parties cannot agree upon a mediator, each party shall select a mediator and those mediators shall select a qualified neutral third party to mediate with regard to the disputed portion of the Claim. Each party shall bear the fees and costs charged by its respective mediator in connection with the selection of the neutral mediator. If mediation is unsuccessful, the parts of the Claim remaining in dispute shall be resolved in accordance with Section 7-1.05 below.

7-1.05 **DISPUTE RESOLUTION PROCEDURE.** All Claims not resolved

pursuant to Section 7-1.04, shall be resolved pursuant to Public Contract Code Section 10240, et seq.

7-1.06 **STOP PAYMENT NOTICES.** The City, by and through the Department or other appropriate office or officers, may at its option and at any time retain out of any amounts due the Contractor, sums sufficient to cover claims, filed pursuant to Civil Code Section 9350, et seq., including an amount to provide for the reasonable cost of any litigation thereunder.

7-1.07 **PROGRESS PAYMENTS.** Within fifteen (15) Days after the effective date in the Notice to Proceed, but in any event prior to Contractor's first Application for Payment, the Contractor shall submit to the City a detailed Schedule of Values.

Upon its approval, the Schedule of Values will form a basis for determining the compensation payable to the Contractor based on its actual progress of Work with respect to each Lump Sum bid item. The City, prior to any progress payment being made, must approve the Schedule of Values.

At the Director's discretion the approved Schedule of Values may be used as the basis for calculating the adjustment in compensation for a lump sum bid item due to changes ordered by the Director. When an ordered change increases or decreases the quantities shown in an approved Schedule of Values, at the Director's discretion, the adjustment in compensation may be determined in the same manner specified for increases and decreases in the quantity of a bid item of work in accordance with Section 3-1.05(B), "Contract Price Adjustment," of these General Conditions.

The Contractor once in each month shall submit an Application for Payment, for approval by the Director. Contractor's Applications shall be based on the Schedule of Values submitted to the City. These applications shall be supported by: (1) documentation requested by the City to

substantiate the payment request; (2) statutory releases from Contractor and all Subcontractors and suppliers pursuant to Civil Code Sections 8132 and 8138; and (3) certified payroll records for the period for which payment is requested. Specifically, the Contractor will submit conditional waivers upon progress payment executed by all contractors and suppliers that will be receiving sums sought in the instant payment request and also submit unconditional waivers upon progress payment executed by all contractors and suppliers that have been paid to the date of the payment request. The Contractor shall certify that the Work for which payment is requested has been accomplished. When requested by the City, the Contractor shall submit receipts, invoices and other documentation that the City requires to be furnished for purpose of evaluating the application.

The City will pay the Contractor within thirty (30) Days after its receipt of an undisputed and properly submitted Application for Payment, after deducting all previous payments, retention, and other sums as described in the Contract Documents. Within seven (7) Days of its receipt of the Contractor's Application for Payment, the City will determine whether it complies with the provisions of the Contract Documents. As appropriate, the City will return the application to the Contractor accompanied by a document prepared by the City setting forth the reasons for the rejection. Thereafter, the Contractor shall correct and resubmit the Application for Payment. Progress payments may be withheld for Work that is not performed in accordance with the Contract Documents.

The City may deduct the following from each progress payment:

1. An amount equal to one hundred and twenty-five percent (125%) of the amount claimed under any stop payment notice or other lien filed against the Contractor, which includes an amount to provide for the reasonable cost of any litigation

thereunder.

2. Any Liquidated Damages or Assessments that have accrued as of the date of the Application for Payment.
3. Any sums expended by the City in performing any of the Contractor's obligations under the Agreement that the Contractor has failed to perform.
4. Any other sums that the City is entitled to recover from the Contractor under the terms of the Contract including damages to the City's property.
5. The failure of the City to deduct any of the above identified sums from a progress payment shall not constitute a waiver of the City's right to such sums.

No such estimate or payment shall be construed to be an acceptance of any defective Work or improper materials.

Under no circumstances will the City make payment to unlicensed Contractors. As a condition of payment, the Contractor is required to maintain the applicable Contractor's license as identified in the Notice to Contractors for the duration of the Work.

7-1.08 **PAYMENT FOR MATERIALS AND EQUIPMENT ON HAND.**

Partial payments may be made to the extent of seventy-five percent (75%) of the cost of materials and equipment plus delivery to be incorporated in the Work, provided that such materials and equipment meet the requirements of the Contract Documents and are delivered to acceptable sites on the plant site or at other sites in the vicinity that are acceptable to the City and only with the prior written approval by the City. Such delivered costs of stored or stockpiled materials and equipment may be included in the next progress payment after the following conditions are met:

- A. Equipment and materials will only be eligible if given conditional or final

Acceptance by the Director and are in apparent compliance with favorably reviewed Submittals.

B. Only equipment or materials which have received favorable review of Shop Drawings will qualify.

C. The material or equipment has been stored or stockpiled adequately protected against damage in a manner acceptable to the Director at an approved site.

D. The Contractor has furnished the Director with acceptable evidence of the quantity and the quality of such stored or stockpiled materials or equipment with identification of where they will be incorporated into the project with Specification reference.

E. The Contractor has furnished the Director with satisfactory evidence that the material or equipment and transportation costs have been paid.

F. The Contractor has furnished the City legal title (free of liens or encumbrances of any kind) and lien releases to the material or equipment so stored or stockpiled.

G. The Contractor has furnished the City evidence that the material or equipment so stored or stockpiled is insured against loss by damage to or disappearance of such materials at any time prior to use in the Work.

It is understood and agreed that the transfer of title and the City payment for such stored or stockpiled materials or equipment shall in no way relieve the Contractor of its responsibility for furnishing and placing such materials or equipment in accordance with the requirements of the Contract Documents.

In no case will the amount of progress payments for materials or equipment on hand exceed the Contract Price for such materials or equipment or the Contract Price for the Contract item in which the material is intended to be used.

No partial payment will be made for stored or stockpiled living or perishable plant

materials.

The Contractor shall bear all costs associated with the progress payment of stored or stockpiled materials or equipment in accordance with the provisions of this Section.

7-1.09 **RETENTION ON PROGRESS PAYMENTS.** From each progress payment estimate, five percent (5%) will be deducted and held in retention by the City. The remainder, less any deductions described in Section 7-1.07, “Progress Payments,” of these General Conditions, will be paid to the Contractor as progress payments.

Pursuant to Public Contract Code Section 22300, the successful Bidder may submit Securities in lieu of retention payments by the City. Upon the Contractor’s request, the City will make payment of funds withheld from progress payments, pursuant to the requirements of California Public Contract Code Section 22300, if the Contractor deposits in escrow with the City or with a bank acceptable to the City, securities eligible for investment under California Government Code Section 16430, bank or savings and loan certificates of deposit, interest bearing demand deposit accounts, standby letters of credit, or any other security mutually agreed to by the Contractor and the City, upon the following conditions:

1. The Contractor shall bear the expenses of the City and the escrow agent in connection with the escrow deposit made.
2. Securities or certificates of deposit to be placed in escrow shall be of a value at least equivalent to the amounts of retention to be paid to the Contractor pursuant to this section.
3. Contractor shall enter into an escrow agreement satisfactory to the City, which agreement shall be substantially similar to the form provided in California Public Contract Code section 22300.

4. The Contractor shall obtain the written consent of the surety to such agreement.

7-1.10 **FINAL PAYMENT.** Final payment will be made only after Contractor has achieved Final Completion of the Work pursuant to the provisions of Section 7-1.01, “Acceptance,” of these General Conditions. Before final payment can be made, the Contractor shall have furnished the City with the following:

1. All Record Documents, catalogues, instruction sheets and information as required by the Contract Documents.
2. Conditional Waivers and Releases Upon Final Payment executed by Contractor and all Subcontractors and Suppliers, as provided by Civil Code Section 8136. Unconditional Waivers and Releases Upon Final Payment, as provided in Civil Code Section 8138, executed by Contractor and all Subcontractors and Suppliers, must be provided for all Subcontractors and Suppliers that have been paid in full.

Within thirty (30) Days of the date of the City’s Acceptance of the Work, the Contractor shall prepare and submit a Final Invoice, showing the proposed total amount due the Contractor, segregated by Bid item quantities, Change Order Work, and other basis for payments; deductions made or to be made for prior payment; and amounts previously retained. Prior invoices and payments shall be subject to correction in the proposed Invoice for Final Payment. Payments to the Contractor will be made only for actual quantities of the Contract items of work constructed in accordance with the Contract Documents.

The City will review the Contractor’s proposed Final Invoice and necessary changes or corrections will be forwarded to the Contractor. Within ten (10) Days thereafter, the Contractor

shall submit a revised proposed Final Invoice incorporating changes or corrections made by the City together with any new claims resulting therefrom. Upon approval by the City, the corrected proposed Final Invoice will become the approval Final Invoice.

If agreements are reached on all questions regarding the Final Invoice, the City will pay the entire sum found due on the approved application. However, the City will withhold sums sufficient to pay all unsettled claims for which stop payment notices have been filed pursuant to Section 9350, et seq. of the California Civil Code, together with the reasonable cost of any litigation thereunder.

Final payment will be made within thirty (30) Days after receipt of an approved Final Invoice and other required Submittals referenced above or within sixty (60) Days after Acceptance of the work by the City, whichever is later, provided, however, that if an approved Final Invoice has not been submitted within sixty (60) Days after Acceptance of the Work by the City, the City may elect to make payment of sums not in dispute without prejudice to the right of either the City or the Contractor in connection with such disputed sums. Notwithstanding the foregoing, if a Notice of Completion is recorded, final payment shall not be made prior to the expiration of the thirty-five (35) calendar day lien period. The start of this lien period is the date the Placer County Recorder's Office records the Notice of Completion.

The City may withhold from the Final Payment an amount not to exceed one hundred fifty percent (150%) of any amount in dispute between the City and the Contractor.

The making of Final Payment shall not operate to release the Contractor or its sureties from obligations arising under the Contract, the Contract bonds and warranties as herein provided. Specifically, the making of final payment shall not constitute a waiver and release of claims by the City arising from:

1. Unsettled or future liens;
2. Failure of the Work to comply with the requirements of the Contract Documents;
3. The terms of any warranties required by or contained in the Contract Documents;
4. The right to any insurance proceeds or the right to make any insurance or bond claims;
5. Any claims with respect to Contractor's obligations of indemnity with respect to claims asserted by third parties; or
6. Any latent deficiencies with the Work or Contractor's fraud.

7-1.11 **CLERICAL ERRORS.** Notwithstanding the provisions of Section 7-1.10, "Final Payment," of these General Conditions, for a period of three (3) years after Acceptance of the Work, all estimates and payments made pursuant to said Section 7-1.10, are subject to correction for clerical errors in the calculations involved in the determination of quantities and payments. The Contractor and the City agree to pay to the other any sum due under the provisions of this Section 7-1.11, provided, however, if the total sum to be paid is less than \$100, no such payment shall be made.

7-1.12 **WARRANTY.** Notwithstanding inspections and Acceptance by the City of Work furnished under the Contract Documents, the Contractor hereby unconditionally guarantees that all materials and equipment furnished will be of good quality and new, that the Work will be free from defects in workmanship and materials and that the Work will conform to the requirements of the Contract Documents. Work not conforming to these requirements, including substitutions not properly approved and authorized, may be considered defective.

This warranty by the Contractor is in addition to any warranties or guarantees required elsewhere in the Contract Documents. This warranty shall be in effect notwithstanding any disclaimers, or limiting or conditional terms contained in such separate warranties furnished by manufacturers or suppliers.

The Contractor hereby agrees to repair or replace any and all Work, together with any other adjacent Work which may be displaced in so doing, that may prove to be not in accordance with the requirements of the Contract or that may be defective in its workmanship or material during the greater of a period of one (1) year after Acceptance of the Work by the City or the period specified in the Special Conditions, without any expense whatsoever to the City, ordinary wear and tear and unusual abuse or neglect excepted.

The Contractor further agrees, that within ten (10) Days after being notified in writing by the Department of any Work not in accordance with the requirements of the Contract Documents or of any defects in the Work, the Contractor will commence and prosecute with due diligence all Work necessary to fulfill the terms of this warranty, and to complete such Work within a reasonable period of time. In the event Contractor fails to comply, it does hereby authorize the Department to proceed to have such Work done at the Contractor's expense and the Contractor will honor and pay the cost and charges therefore upon demand. The Department shall be entitled to all costs and expenses, including reasonable attorneys' fees, necessarily incurred upon the Contractor's refusal to honor and pay the above costs and charges.

All warranties set forth in the Contract Documents shall be deemed cumulative and not alternative or exclusive. Nothing contained in this section shall be construed to establish a period of limitation with respect to any other obligation, which Contractor has under the Contract Documents or under any separate warranty or guaranty required thereby. The establishment of a

specific warranty period relates only to the specific obligation of Contractor to correct defective Work, and it has no relationship to the time within which its obligation to comply with the Contract Documents or applicable provision of law may be sought to be enforced, nor to the time within which proceedings may be commenced to establish Contractor's liability with respect to its obligations other than specifically to correct the Work. Without limiting the foregoing, it is understood and agreed that Contractor shall remain responsible for latent defects with its work, regardless of the expiration of any warranty period set forth in the Contract Documents.

7-1.13 **WARRANTY OF TITLE.** No material, supplies, or equipment for the Work under this Contract shall be purchased subject to any chattel mortgage, security agreement, or under a conditional sale or other agreement by which an interest therein or any part thereof is retained by the seller or supplier. The Contractor warrants good title to all material, supplies, and equipment Installed or incorporated in the Work and agrees upon completion of all Work to deliver the Premises, together with all improvements and appurtenances constructed or placed thereon by it, to the City free from any claim, liens, security interest, or charges, and further agrees that neither the Contractor nor any person, firm, or corporation furnishing any materials or labor for any Work covered by this Contract shall have any right to a lien upon the Premises or any improvement or appurtenances thereon. Provided, that this shall not preclude the Contractor from Installing metering devices and other equipment of utility companies, the title of which is commonly retained by the utility company. In the event of the Installation of any such metering device or equipment, the Contractor shall advise the City as to the legal owner thereof. Nothing contained in this paragraph, however, shall defeat or impair the right of such persons furnishing materials or labor under any bond given by the Contractor for their protection or any rights under any law permitting such persons to look to funds due the Contractor in the hands of the City.

The provisions of this paragraph shall be inserted in all subcontracts and material Contracts, and notice of its provisions shall be given to all persons furnishing materials for the Work when no formal Contract is entered into for such materials.

[END OF GENERAL CONDITIONS]

SUPPLEMENTAL CONDITIONS

Project: Industrial 12kV Underground conversion

Scope of Supplemental Conditions

1. The Work shall be performed in accordance with the General Conditions and Department Standards, except as the General Conditions may be modified by the following additional City Standards, incorporated herein by this reference, if so indicated.

	COMMUNITY DESIGN GUIDELINES 311 Vernon Street, Roseville, CA 95678
X	SPECIFICATIONS FOR COMMERCIAL CONSTRUCTION (ELECTRIC) 2090 Hilltop Circle, Roseville, CA 95747
	PARKS CONSTRUCTION STANDARDS 316 Vernon Street, Suite 400, Roseville, CA 95678
X	DESIGN AND CONSTRUCTION STANDARDS 311 Vernon Street, Roseville, CA 95678
	OTHER

Above documents are available at: www.roseville.ca.us.

2. Numbering in these Supplemental Conditions conforms to that in the General Conditions. The existence of a section in these Supplemental Conditions means that the corresponding section in the General Conditions is modified in some respect. Unless otherwise specified, the modified General Condition is deleted entirely and the provisions of these Supplemental Conditions are substituted.

SECTION 1. DEFINITIONS AND TERMS

1-1.24 **DEPARTMENT.** Section 1-1.24 of the General Conditions is amended to include the following:

The Department for Contract Administration is the Electric Department of the City of Roseville.

SECTION 2. CONTROL AND SCOPE OF THE WORK

2-1.08 **SUBMITTALS.** Section 2-1.08 of the General Conditions is amended to include the following:

The time allowed for review of each submittal is 5 Days after receipt of the submittal by the Director.

SECTION 3. CHANGES IN THE WORK

There are no amendments to the General Conditions.

SECTION 4. CONTROL OF MATERIALS

There are no amendments to the General Conditions.

SECTION 5. LEGAL RELATIONS AND RESPONSIBILITY

5-1.14 **AIR POLLUTION CONTROL AND ASBESTOS.** Section 5-1.14 of the General Conditions is amended to include the following:

To the best of the City's knowledge, asbestos not present in the vicinity of the Project. Additional information shall be made available to Contractor upon request.

SECTION 6. PROSECUTION AND PROGRESS

6-1.04 **PROGRESS SCHEDULE.** Section 6-1.04F of the General Conditions is amended to include the following:

Progress schedules showing project completion dates more than 30 Days earlier than specified in Section 6-1.07 shall be rejected.

6-1.07 **TIME OF COMPLETION.** Section 6-1.07 of the General Conditions is amended to include the following:

The Contractor shall begin Work within 5 business days after receiving a Notice to Proceed and shall diligently prosecute the Work to completion. The Work shall be completed within 30 business days of the Notice to Proceed.

If landscaping plants require an establishment period, that period will be 60 calendar days. Start of the establishment should be as outlined in the Specifications.

6-1.08 **LIQUIDATED DAMAGES.** Section 6-1.08 of the General Conditions is amended to include the following:

The amount of Liquidated Damages is the sum of \$500 per Day.

SECTION 7: ACCEPTANCE AND PAYMENT

There are no amendments to the General Conditions.

[END OF SUPPLEMENTAL CONDITIONS]

SPECIFICATION
Industrial 12kV Underground Conversion
CONSTRUCTION SPECIFICATION

TABLE OF CONTENTS

1. SCOPE OF WORK
2. GENERAL PROVISIONS
3. DRAWING LIST
4. EXISTING SITE CONDITIONS
5. CONSTRUCTION SURVEYING
6. SITE PREPARATION AND GRADING
7. EARTHWORK AND COMPACTION
8. EXCAVATION AND BACKFILLING FOR TRENCHES AND FOUNDATIONS
9. UNDERGROUND CABLE CONDUITS AND TRENCHES
10. EROSION AND SEDIMENT CONTROL

1. SCOPE OF WORK

1.1 This Specification covers the labor, supervision and materials required for the following projects:

1.1.1 This project consists of the following: installation of conduit by boring, installation of Pad Vaults and Pull Boxes.

1.2 Work Included: Contractor shall perform all labor, coordination, supervision, surveying, traffic control, inspection that is required to construct the needed items. All labor, material and associated construction costs are the responsibility of the Contractor unless specifically stated otherwise.

The principal components of the work include, but are not limited to the following:

1.2.1 Establish the reference and boundary lines.

1.2.2 Provide Traffic Control per the City of Roseville Design and Construction Standards.

1.2.3 Bore to install conduits as shown on the plans. Contractor to use Bore-Gard Conduit or approved equal.

1.2.4 Contractor to install City supplied Pull Boxes and Pad Vault per Roseville Electric Commercial Construction Standards. This work is to include all surveying, excavation and compaction.

1.2.5 Supply and implement necessary BMP's for erosion and sediment control.

1.3 This Specification shall be used together with the following:

1.3.1 Construction drawings listed in Section 3.

1.3.2 The Supplemental Conditions.

1.3.3 Roseville Electric Specifications for Commercial Construction.

1.3.4 City of Roseville Design and Construction Standards.

1.3.5 Other standard specifications.

1.3.6 General Conditions for Buildings and Grounds.

In case of any conflicts between the requirements stated above, the order of precedence shall be as follows:

A. Construction drawings listed in Section 3 (highest).

- B. The Supplemental Conditions.
- C. This Specification.
- D. Other standard specifications.
- E. General Conditions for Buildings and Grounds.

2. **GENERAL PROVISIONS**

- 2.1 Contractor shall examine the site and determine the amount, nature and difficulty of the proposed work. Contractor shall evaluate the requirements of the plans, specifications, bid package and existing conditions and bid accordingly. Contractor shall satisfy himself/herself of the soil conditions prior to bidding this project. The contract price shall be based on a lump sum basis.
- 2.2 If there is a doubt as to the true meaning of any part of the plans, specifications, or the contract documents or if discrepancies in or omissions from the drawings or specifications are found, a written request should be made to the City for interpretation. No payment will be made to the Contractor because of error, negligence or failure to become familiar with the existing conditions or requirements of the plans, specifications and bid package.
- 2.3 The safety of all materials and labor used in this project is left solely to the Contractor. Any loss due to weather, acts of God, vandalism, theft, poor workmanship, or any other loss is the responsibility of the Contractor and it is assumed to be part of this bid and bid price. City will not be responsible for the loss of any material and/or labor.
- 2.4 Appropriate tarps and covers shall be used to protect all open trenches, excavations and removed materials that are planned to be used for backfill from wind, rain and other weather conditions.
- 2.5 Underground Service Alert (USA) must be called before any digging is started. The phone number of USA is 1-800-642-2444. There are existing underground installations in the working area including electrical power cables installed by the City, water and sewer lines, gas and telephone facilities. The as-built drawings are available for inspection at the Electric Department. These drawings are not exact and the Contractor agrees to hold the City harmless for any errors that may be on the plans or for any damage that the Contractor may do to existing facilities due to the plans. Any damage to existing underground facilities including the electrical power cables or to the conduit system done by the Contractor is the complete responsibility of the Contractor. There are existing overhead conductors energized at 12,000 volts on and adjacent to this site.
- 2.6 Contractor shall coordinate and comply with the statutory requirements of all relevant authorities for the due and lawful prosecution of the work. The contractor shall be liable for all monetary fines assessed during construction due to non-compliance on the part of the contractor and subcontractors.

- 2.7 Unless otherwise approved by the Engineer, the normal working hours shall be limited to Monday through Friday, excluding City's holidays, between 7 a.m. and 3:30 p.m.
- 2.8 The following lists the items that will be furnished by the City: Pull Boxes and Pad Vaults
- 2.9 A mandatory prebid meeting will be held in accordance with meeting details posted on the Public Purchase website which will include an inspection of the project site.

- 2.11 **Prevailing Wages and DIR Registration Notice** - A portion of the services described herein are for publicly funded projects, considered "public works" as defined by California Labor Code Section 1720 et seq. Any Contractor awarded a contract as the result of this bid shall be responsible for compliance with all applicable prevailing wage laws, as well as any and all applicable state or federal wage laws, for services performed under any resulting contract. Fee schedules must differentiate hourly rates for public works and private development projects and be consistent with applicable prevailing wage requirements.

Provide documentation verifying that your firm and any sub-consulting firm is registered with the Department of Industrial Relations (DIR), including the Public Works Contractor (PWC) Registration Number for all firms. Consultants are hereby notified that this agreement and task agreements hereunder are, as applicable, subject to compliance monitoring and enforcement by DIR.

- 2.12 **Mitigation Monitoring and Reporting –**

Mitigation Measure CR-1 (Previously Unidentified Cultural Resources)

- (a) Construction shall stop if potential cultural resources are encountered. It is possible that previous activities have obscured surface evidence of cultural resources. If signs of an archeological site, such as any unusual amounts of stone, bone, or shell, are uncovered during grading or other construction activities, work shall be halted within 100 feet of the find and the Roseville City Manager's Office shall be notified. A qualified archeologist shall be consulted for an on-site evaluation. If the site is or appears to be eligible for listing in state or federal registers, additional mitigation, such as further testing for evaluation or data recovery, may be necessary.
- (b) In the event resources are discovered, the City shall request a qualified archaeologist assess the find and determine whether the resource requires further study. Any previously undiscovered resources found during construction should be recorded on appropriate Department of Parks and Recreation (DPR) 523 forms and evaluated for significance under all applicable regulatory criteria. No further grading shall occur in the area of the discovery until the City approves the measures to protect the resources. Any archaeological artifacts recovered as a

result of mitigation shall be donated to a qualified scientific institution approved by the Lead Agency where they would be afforded long-term preservation to allow future scientific study.

Mitigation Measure CR-2 (Previously Unidentified Paleontological Resources)

If substantial fossil remains (particularly vertebrate remains) are discovered during earth-disturbing activities on the project site, activities will stop immediately until a state-registered professional geologist or qualified professional paleontologist can assess the nature and importance of the find and a qualified professional paleontologist can recommend appropriate treatment. Treatment may include preparation and recovery of fossil materials so that they can be housed in an appropriate museum or university collection and may also include preparation of a report for publication describing the finds. The applicant will be responsible for ensuring that recommendations regarding treatment and reporting are implemented.

Mitigation Measure CR-3 (Inadvertent Discovery of Human Remains)

If human remains are discovered during any phase of construction, including disarticulated or cremated remains, the construction contractor shall immediately cease all ground-disturbing activities within 100 feet of the remains and notify Terri Shirhall, Environmental Coordinator, City of Roseville Development Services.

In accordance with California State Health and Safety Code Section 7050.5, no further disturbance shall occur until the following steps have been completed:

- (a) The County Coroner has made the necessary findings as to origin and disposition pursuant to Public Resources Code (PRC) § 5097.98.
- (b) If the remains are determined by the County Coroner to be Native American, the NAHC shall be notified within 24 hours, and the guidelines of the NAHC shall be adhered to in the treatment and disposition of the remains. It is further recommended that a professional archaeologist with Native American burial experience conduct a field investigation of the specific site and consult with the Most Likely Descendant (MLD), if any, identified by the NAHC. As necessary and appropriate, a professional archaeologist may provide technical assistance to the MLD, including but not limited to, the excavation and removal of the human remains.

3. DRAWING LIST

Industrial 12kv Underground Conversion

4. EXISTING SITE CONDITIONS

- 4.1 Existing overhead electrical cables energized at 12,000 volts.

- 4.2 Existing underground communications and gas lines in the vicinity of project limits.
- 4.3 Project will require boring under the creek.
- 4.4 Existing vernal poles have been identified within the project limits. All construction activities shall not be within these areas.
- 4.5 Topographic Survey has not been conducted on the site.

5. CONSTRUCTION SURVEYING

- 5.1 The Contractor shall lay out all proposed improvements in accordance with the plans and these specifications.
- 5.2 The final placement of all proposed improvements shall be coordinated in the field with the designated Roseville Electric representative.

6. SITE PREPARATION AND GRADING

- 6.1 Contractor shall prepare the site in accordance with the drawings and these specifications. Site preparation shall include clearing of existing debris, grading and sub-grade preparation. All trench work must be inspected by Roseville Electric before backfilling.
- 6.2 Sub-grade preparation shall include areas that will receive crushed rock and aggregate base.
- 6.3 Clearing shall consist of removal of debris, vegetation, waste, or other unacceptable sub-grade material.
- 6.4 Grading shall include construction of embankment, cutting, shaping, blading, and rolling and all other operations necessary to achieve the proposed elevations, slope and compaction.

7. EARTHWORK AND COMPACTION

- 7.1 The soil compaction tests shall be performed by an independent testing laboratory approved by the Engineer. The laboratory shall be retained by the Contractor and all costs for laboratory services shall be paid by the Contractor.

8. EXCAVATION/INSTALLATION AND BACKFILL FOR TRENCHES AND CONDUITS

- 8.1 Excavation, backfill, and compaction for trenches and structures shall be in accordance with the drawings and these specifications
- 8.2 Conduit Installation by Horizontal Installation Method - The Contractor shall furnish and install the proposed conduit adjacent to the roadway and under the creek by Horizontal Directional Drilling (directional boring) construction methods. The

work includes, but not limited to, geotechnical investigations (potholing), excavations, dewatering, removal of material not required in the work, testing, cleaning, and incidentals as shown on the plans and these special provisions.

The Contractor shall furnish all items necessary to perform the Horizontal Directional Drilling.

Install conduit to a minimum depth of 4 feet. If you must install a conduit less than 4 feet in depth or greater than 6 feet in depth, the installation must be authorized.

The diameter of the bore hole must be no larger than 1.5 times the outside diameter of the conduit. Water-based mineral slurry or wetting solution may be used to lubricate the boring tool and stabilize the soil surrounding the boring path.

Disposal of residue must comply with section 13-4.03D.

The horizontal directional drilling equipment must have directional control of the boring tool and have an electronic boring tool location detection system. During operation, the equipment must be able to determine the location of the tool both horizontally and vertically.

Do not use slurry cement backfill.

Use a mandrel to prove the conduit is free and clear of dirt, rocks, and other debris after installation.

- 8.3 All excavation shall be to the lines and grades required for foundations, conduits, grounding and other facilities. Excavation shall be large enough to allow form removal and working space to backfill and compact.
- 8.4 Backfill shall be free of organic matter, large rocks or any other deleterious material. Rocks or clods larger than 1-1/2 inches in diameter will not be allowed within 6 inches of any conduit or ground wire. All backfill will be subject to the approval of the Engineer. Backfill shall be watered and aerated to an optimum moisture content in successive lifts not to exceed six inches and compacted to relative density of 95 percent.
- 8.5 No backfill shall be made until the work to be covered has been approved by the Engineer. External back filling materials must be approved by the Engineer before use.
- 8.6 Contractor shall locate, protect, shore, brace, support, and maintain all existing underground pipes, conduits, drains, and other underground construction which may be uncovered or otherwise affected by the work.
- 8.7 Existing improvements and underground facilities have been plotted from the best information available. However, this information is not complete or accurate. There may be additional existing facilities. The utility information shown on the plans shall not relieve the Contractor of the responsibility of using caution and good judgment. It is the responsibility of the Contractor to ascertain the exact location of all existing facilities and

to avoid damaging them.

- 8.8 Existing improvements that are damaged shall be replaced to an original or better condition. All repair and restoration shall be to the satisfaction of the City of Roseville.

excavation and drilling near the cables location identified by the Electric Department as part of the USA requirements.

9. UNDERGROUND CABLE CONDUITS AND TRENCHES

- 9.1 Power conduits and couplings shall be minimum Schedule 40 PVC. The solvent used shall be in accordance with ASTM-2564 for PVC. All conduits shall be blown free of water and debris. Mule tape to be installed in each conduit per Roseville Electric Construction Standards.

- 9.2 All conduits shall be proven by a proving mandril equal to 80 percent of the conduit diameter. The proving tests shall be witnessed and approved by the Engineer or his representative.

10. EROSION AND SEDIMENT CONTROL

- 10.1 Contractor shall supply and implement all necessary Best Management Practices (BMP's) in order to control erosion and prevent sediment from entering the stormwater system.

- 10.2 Measures shall include but not limited to the following:

10.2.1 Geotextiles and mats.

10.2.2 Velocity dissipation devices.

10.2.3 Silt fence.

10.2.4 Sediment basin or trap.

10.2.5 Fiber rolls.

10.2.6 Street sweeping and vacuuming.

10.2.7 Sand bag or straw bale barrier.

10.2.8 Storm drain inlet protection.

10.2.9 Biofilter bags.

10.2.10 Wind erosion control by applying water suppressants.

10.2.11 Entrance/outlet tire wash or wash station for necessary equipment.

DRAWINGS

Project: Industrial 12kV Underground Conversion

DRAW

Industrial 12kV Underground Conversion

PLAN FOR ELECTRIC UTILITY IMPROVEMENTS

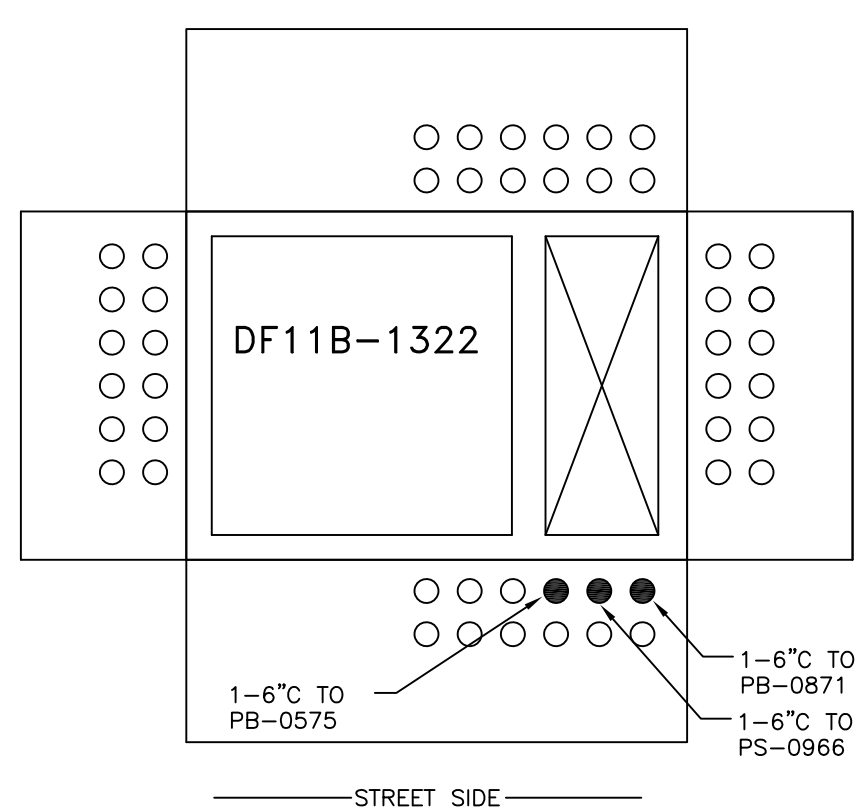
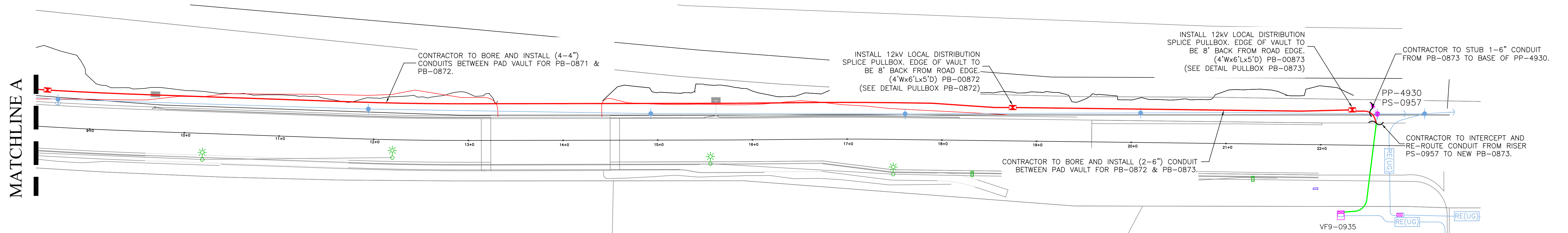
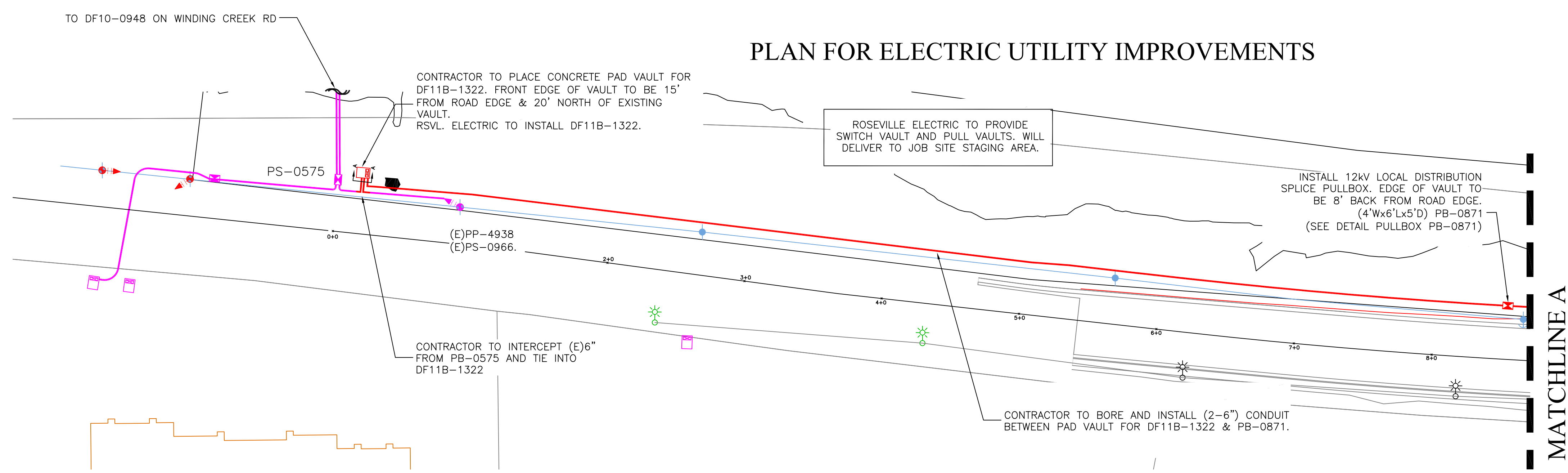
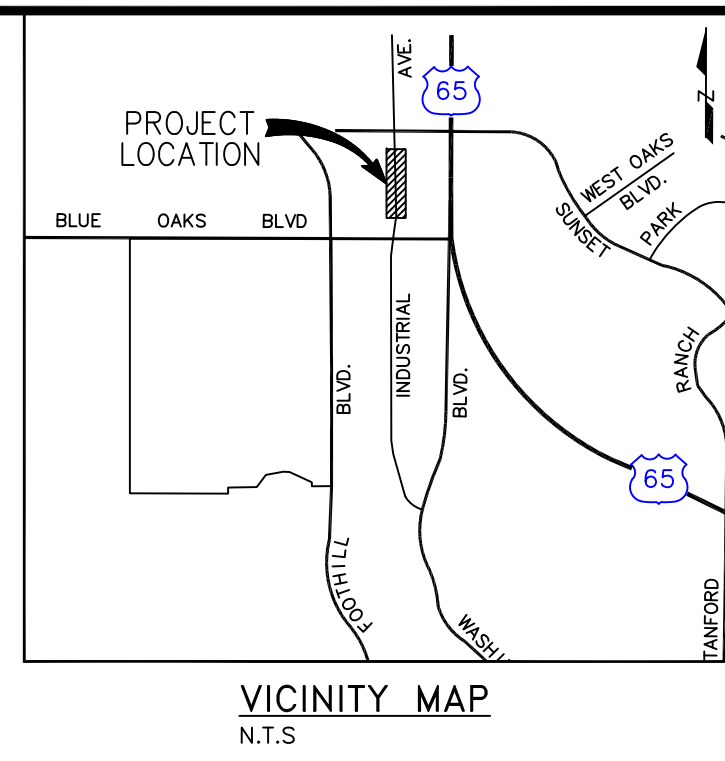
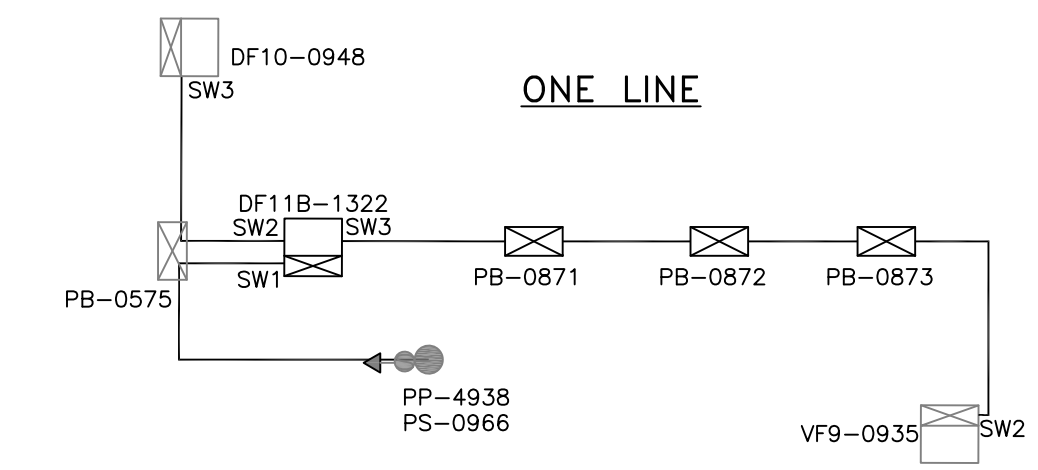

DETAIL PAD VAULT DF11B-1322
STA. 00+13, Industrial Av N.T.S.

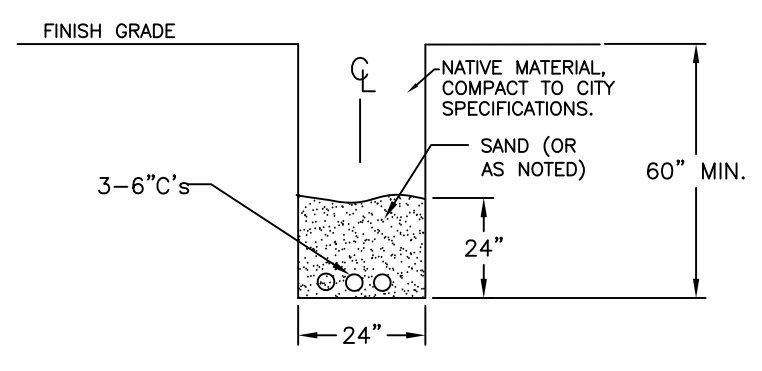

TRENCH DETAIL A-A
N.T.S.

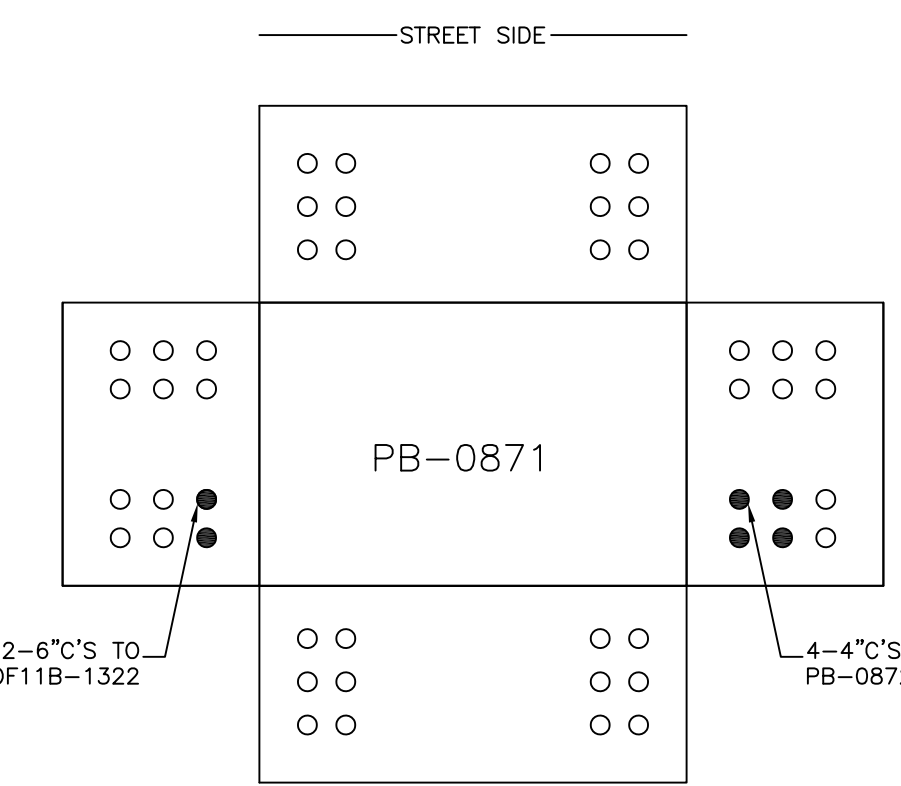
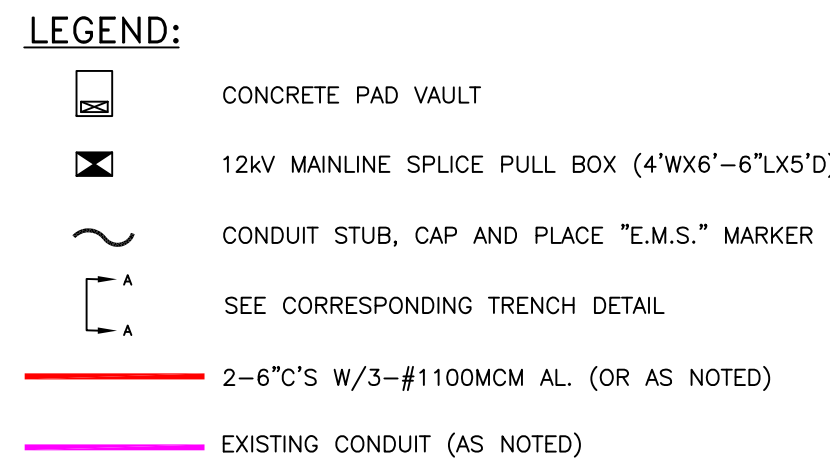

DETAIL PULL BOX PB-0871
STA. 5+80, Industrial Av N.T.S.

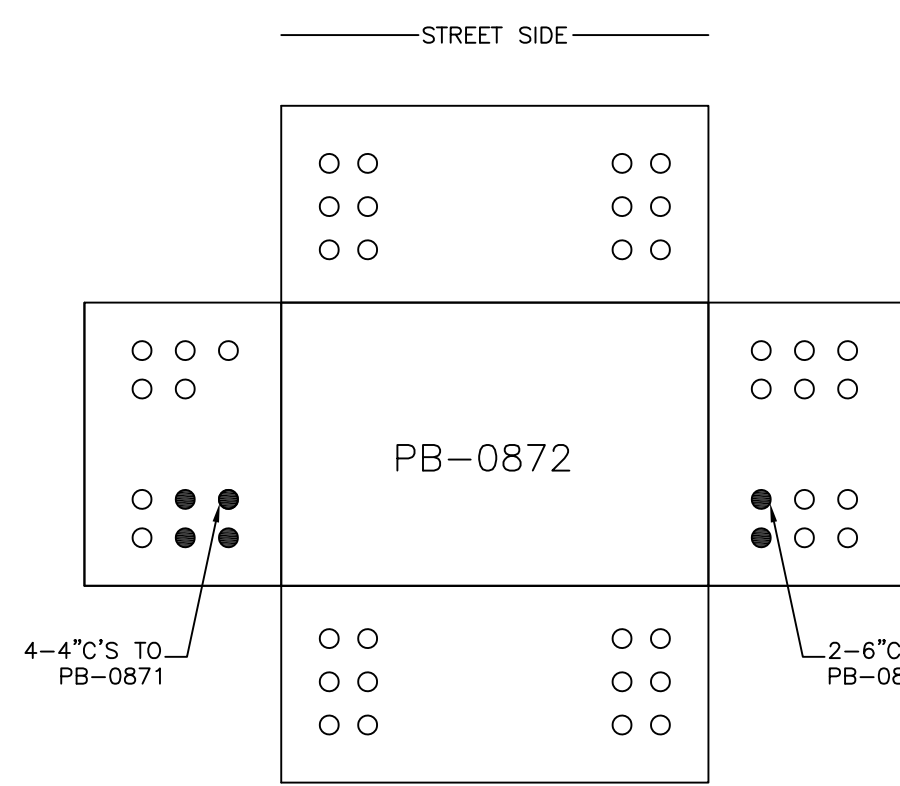

DETAIL PULL BOX PB-0872
STA. 18+74, Industrial Av N.T.S.

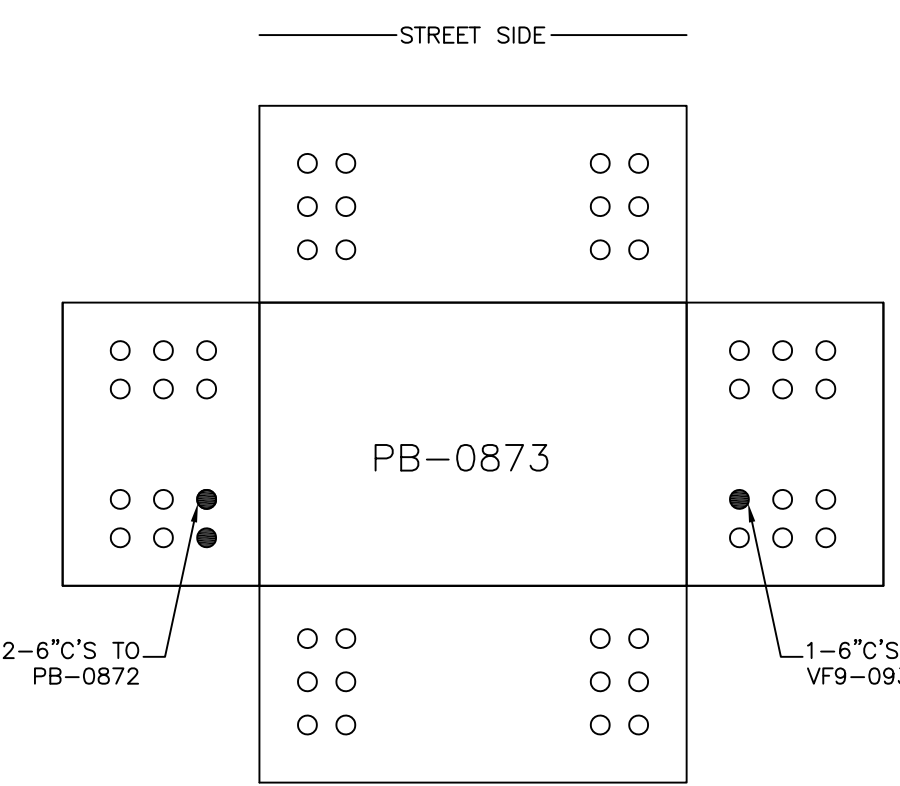

DETAIL PULL BOX PB-0873
STA. 22+33, Industrial Av N.T.S.

- NOTES:**
- "ROSEVILLE ELECTRIC'S SPECIFICATIONS FOR COMMERCIAL CONSTRUCTION" ARE A PART OF THESE CONSTRUCTION PLANS FOR THIS DESIGN AND SHALL BE ADHERED TO UNLESS OTHERWISE DIRECTED BY SPECIFIC COMMENTS OR DETAILS IN THESE PLANS.
 - A MINIMUM SEPARATION OF 5' WHEN PARALLELING AND BY AT LEAST 6" WHEN CROSSING IS REQUIRED BETWEEN ELECTRIC AND OTHER SUBSTRUCTURES (WATER, SEWER, STORM DRAIN, ETC.). THE CROSSING SEPARATION MAY BE REDUCED TO 3" WHEN ELECTRIC CONDUITS ARE CONCRETE ENCASED AND APPROVED BY THE ELECTRIC DEPARTMENT INSPECTOR.
 - A MINIMUM OF 5' WHEN PARALLELING AND 12" WHEN CROSSING PG&E GAS TRANSMISSION LINES.
 - A MINIMUM 12" SEPARATION BETWEEN ELECTRIC, TELEPHONE, GAS AND CABLE T.V. IS REQUIRED. THIS SEPARATION MAY NOT BE REDUCED UNLESS SPECIFICALLY APPROVED IN EACH INSTANCE BY THE UTILITIES INVOLVED.
 - THE CONTRACTOR TO PAY SPECIAL ATTENTION TO CROSSINGS WITH WATER MAINS, SANITARY SEWER, DRAIN PIPES, AND ANY OTHER OBSTRUCTIONS. CONTRACTOR TO PROVIDE THE MINIMUM REQUIRED COVER FOR ALL UTILITIES WITH A SMOOTH TRANSITION OVER OR UNDER OBSTRUCTION AS DIRECTED AND APPROVED BY ALL UTILITIES INVOLVED. THE APPROACH AND DEPARTURE FOR AN OBSTRUCTION SHALL BEGIN AND END 100 LINEAL FEET AWAY FROM THE OBSTRUCTION.
 - TRENCH DETAILS SHOWN ON THESE PLANS ARE FOR ELECTRIC. IF OTHER UTILITIES REQUEST JOINT TRENCH OCCUPATION, THE TRENCH DIMENSIONS MAY BE MODIFIED. IT IS THE DEVELOPER'S RESPONSIBILITY TO CO-ORDINATE SUCH REQUESTS TO THE SATISFACTION OF ALL THE UTILITIES INVOLVED.
 - CONTRACTOR SHALL INSURE THAT ALL TRENCHING AND INSTALLATION OF ELECTRIC FACILITIES CONFORMS TO CAL. O.S.H.A. AND THE STATE OF CALIFORNIA P.U.C. GENERAL ORDER NO. 128 REQUIREMENTS.
 - THE CITY OF ROSEVILLE IS A MEMBER OF THE UNDERGROUND SERVICE ALERT SYSTEM, CALL BEFORE YOU DIG! U.S.A PHONE #800-642-2444. ROSEVILLE ELECTRIC DISPATCH PHONE #916-774-5620.



REV	BY	DATE	DESCRIPTION	APPR.

Industrial 12kV Underground Conversion
 MAXIMO NO. 2266031
 ACCOUNT NO. 6001-6587-84701-500174-01070
 DRAWING NO. 510-0487
 SHEET 1 OF 1

TEXT OF AB 626

Assembly Bill No. 626

CHAPTER 810

An act to add and repeal Section 9204 of the Public Contract Code, relating to public contracts.

[Approved by Governor September 29, 2016. Filed with Secretary of State September 29, 2016.]

LEGISLATIVE COUNSEL'S DIGEST

AB 626, Chiu. Public contracts: claim resolution.

Existing law prescribes various requirements regarding the formation, content, and enforcement of state and local public contracts. Existing law applicable to state public contracts generally requires that the resolution of claims related to those contracts be subject to arbitration. Existing law applicable to local agency contracts prescribes a process for the resolution of claims related to those contracts of \$375,000 or less.

This bill would establish, for contracts entered into on or after January 1, 2017, a claim resolution process applicable to any claim by a contractor in connection with a public works project. The bill would define a claim as a separate demand by the contractor for one or more of the following: a time extension for relief from damages or penalties for delay, payment of money or damages arising from work done pursuant to the contract for a public work, or payment of an amount disputed by the public entity, as specified.

This bill would require a public entity, defined to exclude certain state entities, upon receipt of a claim sent by registered or certified mail, to review it and, within 45 days, provide a written statement identifying the disputed and undisputed portions of the claim. The bill would authorize the 45-day period to be extended by mutual agreement. The bill would require any payment due on an undisputed portion of the claim to be processed within 60 days, as specified. The bill would require that the claim be deemed rejected in its entirety if the public entity fails to issue the written statement.

This bill would authorize, if the claimant disputes the public entity's written response or if the public entity fails to respond to a claim within the time prescribed, the claimant to demand to meet and confer for settlement of the issues in dispute. The bill would require any disputed portion of the claim that remains in dispute after the meet and confer conference to be subject to nonbinding mediation, as specified. The bill would provide that unpaid claim amounts accrue interest at 7% per annum. The bill would prescribe a procedure by which a subcontractor or lower tier contractor may make a claim through the contractor.

This bill would require the text of these provisions, or a summary, to be set forth in the plans or specifications for any public work which may give rise to a claim. The bill would specify that a waiver of these rights is void and contrary to public policy, except as specified. The bill would also specify that it does not impose liability on a public entity that makes loans or grants available through a competitive application process, for the failure of an awardee to meet its contractual obligations.

By increasing the duties of local agencies and officials, this bill would impose a state-mandated local program.

This bill would, on January 1, 2020, repeal the provision establishing the claim resolution process.

This bill would specify that these provisions constitute a matter of statewide concern.

The California Constitution requires the state to reimburse local agencies and school districts for certain costs mandated by the state. Statutory provisions establish procedures for making that reimbursement.

This bill would provide that, if the Commission on State Mandates determines that the bill contains costs mandated by the state, reimbursement for those costs shall be made pursuant to these statutory provisions.

The people of the State of California do enact as follows:

SECTION 1. Section 9204 is added to the Public Contract Code, to read:

9204. (a) The Legislature finds and declares that it is in the best interests of the state and its citizens to ensure that all construction business performed on a public works project in the state that is complete and not in dispute is paid in full and in a timely manner.

(b) Notwithstanding any other law, including, but not limited to, Article 7.1 (commencing with Section 10240) of Chapter 1 of Part 2, Chapter 10 (commencing with Section 19100) of Part 2, and Article 1.5 (commencing with Section 20104) of Chapter 1 of Part 3, this section shall apply to any claim by a contractor in connection with a public works project.

(c) For purposes of this section:

(1) "Claim" means a separate demand by a contractor sent by registered mail or certified mail with return receipt requested, for one or more of the following:

(A) A time extension, including, without limitation, for relief from damages or penalties for delay assessed by a public entity under a contract for a public works project.

(B) Payment by the public entity of money or damages arising from work done by, or on behalf of, the contractor pursuant to the contract for a public works project and payment for which is not otherwise expressly provided or to which the claimant is not otherwise entitled.

(C) Payment of an amount that is disputed by the public entity.

(2) "Contractor" means any type of contractor within the meaning of Chapter 9 (commencing with Section 7000) of Division 3 of the Business and Professions Code who has entered into a direct contract with a public entity for a public works project.

(3) (A) "Public entity" means, without limitation, except as provided in subparagraph (B), a state agency, department, office, division, bureau, board, or commission, the California State University, the University of California, a city, including a charter city, county, including a charter county, city and county, including a charter city and county, district, special district, public authority, political subdivision, public corporation, or nonprofit transit corporation wholly owned by a public agency and formed to carry out the purposes of the public agency.

(B) "Public entity" shall not include the following:

(i) The Department of Water Resources as to any project under the jurisdiction of that department.

(ii) The Department of Transportation as to any project under the jurisdiction of that department.

(iii) The Department of Parks and Recreation as to any project under the jurisdiction of that department.

(iv) The Department of Corrections and Rehabilitation with respect to any project under its jurisdiction pursuant to Chapter 11 (commencing with Section 7000) of Title 7 of Part 3 of the Penal Code.

(v) The Military Department as to any project under the jurisdiction of that department.

(vi) The Department of General Services as to all other projects.

(vii) The High-Speed Rail Authority.

(4) "Public works project" means the erection, construction, alteration, repair, or improvement of any public structure, building, road, or other public improvement of any kind.

(5) "Subcontractor" means any type of contractor within the meaning of Chapter 9 (commencing with Section 7000) of Division 3 of the Business and Professions Code who either is in direct contract with a contractor or is a lower tier subcontractor.

(d) (1) (A) Upon receipt of a claim pursuant to this section, the public entity to which the claim applies shall conduct a reasonable review of the claim and, within a period not to exceed 45 days, shall provide the claimant a written statement identifying what portion of the claim is disputed and what portion is undisputed. Upon receipt of a claim, a public entity and a contractor may, by mutual agreement, extend the time period provided in this subdivision.

(B) The claimant shall furnish reasonable documentation to support the claim.

(C) If the public entity needs approval from its governing body to provide the claimant a written statement identifying the disputed portion and the undisputed portion of the claim, and the governing body does not meet within the 45 days or within the mutually agreed to extension of time following receipt of a claim sent by registered mail or certified mail, return receipt requested, the public entity shall have up to three days following the next duly publicly noticed meeting of the governing body after the 45-day period, or extension, expires to provide the claimant a written statement identifying the disputed portion and the undisputed portion.

(D) Any payment due on an undisputed portion of the claim shall be processed and made within 60 days after the public entity issues its written statement. If the public entity fails to issue a written statement, paragraph (3) shall apply.

(2) (A) If the claimant disputes the public entity's written response, or if the public entity fails to respond to a claim issued pursuant to this section within the time prescribed, the claimant may demand in writing an informal conference to meet and confer for settlement of the issues in dispute. Upon receipt of a demand in writing sent by registered mail or certified mail, return receipt requested, the public entity shall schedule a meet and confer conference within 30 days for settlement of the dispute.

(B) Within 10 business days following the conclusion of the meet and confer conference, if the claim or any portion of the claim remains in dispute, the public entity shall provide the claimant a written statement identifying the portion of the claim that remains in dispute and the portion that is undisputed. Any payment due on an undisputed portion of the claim shall be processed and made within 60 days after the public entity issues its written statement. Any disputed portion of the claim, as identified by the contractor in writing, shall be submitted to nonbinding mediation, with the public entity and the claimant sharing the associated costs equally. The public entity and claimant shall mutually agree to a mediator within 10 business days after the disputed portion of the claim has been identified in writing. If the parties cannot agree upon a mediator, each party shall select a mediator and those mediators shall select a qualified neutral third party to mediate with regard to the disputed portion of the claim. Each

party shall bear the fees and costs charged by its respective mediator in connection with the selection of the neutral mediator. If mediation is unsuccessful, the parts of the claim remaining in dispute shall be subject to applicable procedures outside this section.

(C) For purposes of this section, mediation includes any nonbinding process, including, but not limited to, neutral evaluation or a dispute review board, in which an independent third party or board assists the parties in dispute resolution through negotiation or by issuance of an evaluation. Any mediation utilized shall conform to the timeframes in this section.

(D) Unless otherwise agreed to by the public entity and the contractor in writing, the mediation conducted pursuant to this section shall excuse any further obligation under Section 20104.4 to mediate after litigation has been commenced.

(E) This section does not preclude a public entity from requiring arbitration of disputes under private arbitration or the Public Works Contract Arbitration Program, if mediation under this section does not resolve the parties' dispute.

(3) Failure by the public entity to respond to a claim from a contractor within the time periods described in this subdivision or to otherwise meet the time requirements of this section shall result in the claim being deemed rejected in its entirety. A claim that is denied by reason of the public entity's failure to have responded to a claim, or its failure to otherwise meet the time requirements of this section, shall not constitute an adverse finding with regard to the merits of the claim or the responsibility or qualifications of the claimant.

(4) Amounts not paid in a timely manner as required by this section shall bear interest at 7 percent per annum.

(5) If a subcontractor or a lower tier subcontractor lacks legal standing to assert a claim against a public entity because privity of contract does not exist, the contractor may present to the public entity a claim on behalf of a subcontractor or lower tier subcontractor. A subcontractor may request in writing, either on his or her own behalf or on behalf of a lower tier subcontractor, that the contractor present a claim for work which was performed by the subcontractor or by a lower tier subcontractor on behalf of the subcontractor. The subcontractor requesting that the claim be presented to the public entity shall furnish reasonable documentation to support the claim. Within 45 days of receipt of this written request, the contractor shall notify the subcontractor in writing as to whether the contractor presented the claim to the public entity and, if the original contractor did not present the claim, provide the subcontractor with a statement of the reasons for not having done so.

(e) The text of this section or a summary of it shall be set forth in the plans or specifications for any public works project that may give rise to a claim under this section.

(f) A waiver of the rights granted by this section is void and contrary to public policy, provided, however, that (1) upon receipt of a claim, the parties may mutually agree to waive, in writing, mediation and proceed directly to the commencement of a civil action or binding arbitration, as applicable; and (2) a public entity may prescribe reasonable change order, claim, and dispute resolution procedures and requirements in addition to the provisions of this section, so long as the contractual provisions do not conflict with or otherwise impair the timeframes and procedures set forth in this section.

(g) This section applies to contracts entered into on or after January 1, 2017.

(h) Nothing in this section shall impose liability upon a public entity that makes loans or grants available through a competitive application process, for the failure of an awardee to meet its contractual obligations.

(i) This section shall remain in effect only until January 1, 2020, and as of that date is

repealed, unless a later enacted statute, that is enacted before January 1, 2020, deletes or extends that date.

SECTION 2.

The Legislature finds and declares that it is of statewide concern to require a charter city, charter county, or charter city and county to follow a prescribed claims resolution process to ensure there are uniform and equitable procurement practices.

SECTION 3.

If the Commission on State Mandates determines that this act contains costs mandated by the state, reimbursement to local agencies and school districts for those costs shall be made pursuant to Part 7 (commencing with Section 17500) of Division 4 of Title 2 of the Government Code.